



724



VALVOLA A SFERA
PER INDUSTRIA



BALL VALVE FOR
INDUSTRIAL APPLICATION



VANNE A TOURNANT SPHERIQUE
POUR APPLICATION
INDUSTRIELLE



KUGELVENTIL FUR INDUSTRIELLE
ANWENDUNGEN



INTRODUZIONE

Le presenti istruzioni devono essere lette prima dell'installazione e/o messa in servizio al fine di evitare danni a cose o pericoli alle persone.

SIMBOLI

In queste istruzioni per l'uso, vengono impiegate le seguenti illustrazioni come simboli di avvertimento e di indicazione:

INDICAZIONE

 Questo simbolo segnala l'indicazione che installatore/gestore deve particolarmente osservare.

ATTENZIONE!

 Questo simbolo si riferisce a operazioni e istruzioni che devono essere precisamente eseguite, al fine di evitare danni o distruzioni del dispositivo.

PERICOLO!

 Questo simbolo si riferisce a operazioni e istruzioni, che devono essere precisamente eseguite, al fine di evitare pericoli alle persone.

TRASPORTO E IMMAGAZZINAMENTO

Le valvole non devono subire urti o cadute che potrebbero pregiudicare la resistenza strutturale delle parti soggette a pressione. Le valvole devono essere stoccate in ambienti con la temperatura compresa tra -10° e 50°C , e non devono essere sottoposte ad irraggiamento U.V.

AVVERTENZA

 Evitare sempre brusche manovre di chiusura e proteggere la valvola da manovre accidentali.

 La valvola è specificamente studiata per applicazioni di trasporto acqua.

DATI TECNICI

CARATTERISTICHE TECNICHE

Valvola a sfera, bighiera, per applicazioni industriali a smontaggio radiale con supporto regolabile su sfera tonda. Versioni disponibili per incollaggio femmina ISO metrico (1V724 1A724), BS standard (3V724 3A724), e filettata femmina BSP (1V725). Su richiesta, possibilità di esecuzioni in altri standard internazionali (ASTM, JIS, NPT).

CARATTERISTICHE DEL MATERIALE

Valvola in PVC grigio / ABS grigio con maniglia in PVC rosso. Guarnizioni in EPDM o FPM. Sedi sfera in PTFE.

GAMMA

Serie metrica da D16 mm fino a D110 mm, serie filettata BSP da G 3/8" fino a G 4", serie BS per incollaggio da D 3/8" fino a D 4".

CONDIZIONI DI ESERCIZIO

PN 16 a 20°C . D16-3/8" - D63-2"
PN 10 a 20°C D75-2 1/2" - D110-4"

STANDARD DI RIFERIMENTO

Serie per giunzione ISO metrica per incollaggio secondo ISO 727, EN 1452/4 (PVC), accoppiabili con tubazioni conformi a ISO 161/1, EN 1452/2 (PVC), EN ISO 15493.

Serie per giunzioni BS per incollaggio secondo BS 4346/1 (PVC), BS 5392-1 (ABS), accoppiabili con tubazioni conformi BS 3506, BS 3505 (PVC), BS 5391-1 (ABS).

Serie per giunzione filettata BSP secondo UNI ISO 228/1, DIN 2999, BS 21.

1 1V 724 / 1A 724

D	DN	L	Z	C	E	H	B	g PVC-U	g ABS
16	10	14	54	82	53	51	66	150	120
20	15	16	50	82	53	51	66	145	115
25	20	19	53	91	62	59	77	220	175
32	25	22	59	103	71	66	88	315	250
40	32	26	68	120	84	77	102	505	400
50	40	31	77	139	98	87	117	725	565
63	50	38	98	174	117	105	140	1245	970
75	65	44	142	230	168	138	225	3400	2700
90	80	51	142	244	168	138	225	3500	2800
110	100	61	162	284	210	171	280	5900	4700

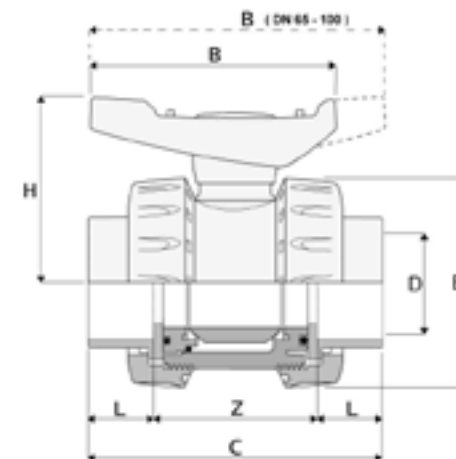

2 1V 725

D	DN	L	Z	C	E	H	B	g PVC-U
3/8"	10	13	56	82	53	51	66	150
1/2"	15	17	56	90	53	51	66	145
3/4"	20	19	55	93	62	59	77	220
1"	25	22	66	110	71	66	88	315
1 1/4"	32	24	79	127	84	77	102	505
1 1/2"	40	24	83	131	98	87	117	725
2"	50	29	103	161	117	105	140	1245
2 1/2"	65	33	164	230	168	138	225	3400
3"	80	36	172	244	168	138	225	3500
4"	100	42	200	284	210	171	280	5900

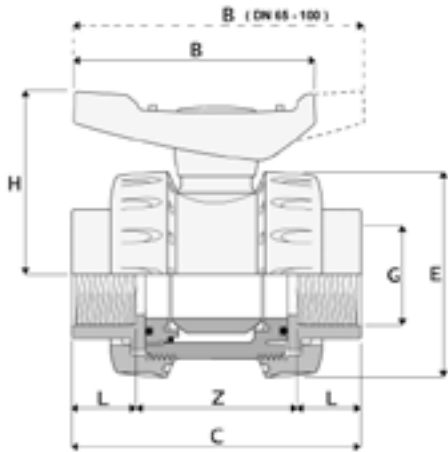
3 3V 724 / 3A 724

D	DN	L	Z	C	E	H	B	g PVC-U	g ABS
3/8"	10	15	52	82	53	51	66	150	120
1/2"	15	17	48	82	53	51	66	145	115
3/4"	20	19	53	91	62	59	77	220	175
1"	25	22	59	103	71	66	88	315	250
1 1/4"	32	26	68	120	84	77	102	505	400
1 1/2"	40	31	77	139	98	87	117	725	565
2"	50	38	98	174	117	105	140	1245	970
2 1/2"	65	44	142	230	168	138	225	3400	2700
3"	80	51	142	244	168	138	225	3500	2800
4"	100	61	162	284	210	171	280	5900	4700

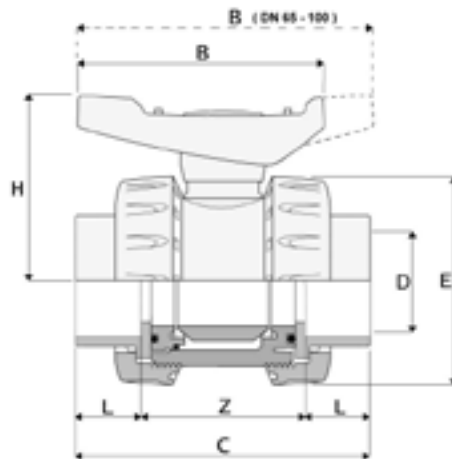

PROCEDURE D'INSTALLAZIONE

Accertarsi che le tubazioni siano in asse.

Svitare le ghiera (1) e inserirle nell'estremità del tubo.

Procedere all'incollaggio o avvitamento dei collarini (2) sulle estremità dei tubi.

Posizionare la valvola tra i collarini mantenendola in asse, ponendo la scritta "reg adj" presente sul corpo (3) a monte della direzione del flusso.

Serrare la ghiera a valle rispetto alla direzione del fluido.

Serrare l'altra ghiera in corrispondenza della scritta "reg adj" (a monte rispetto alla direzione del fluido) fino a raggiungere la perfetta tenuta della valvola.

SMONTAGGIO VALVOLA

Isolare la valvola dal flusso presente in impianto.

Svitare completamente le ghiera (1) e estrarre radialmente la valvola.

Dopo aver portato la valvola in posizione di chiusura, estrarre la maniglia (6) ed utilizzarla per la rimozione con movimento antiorario, del supporto filettato (5).

Premere sulla sfera (4) dal lato cieco, avendo cura di non rigarla, fino alla sua completa fuoriuscita dal corpo.

Premere sull'asta comando (7) verso l'interno del corpo valvola, fino ad ottenere la fuoriuscita.

Estrarre le guarnizioni dalle loro sedi.

MONTAGGIO VALVOLA

Inserire l'asta comando (7) dall'interno del corpo della valvola.

Inserire la guarnizione in PTFE (9) nella sede del corpo (3)

Inserire la sfera (4).

Avvitare nel corpo il supporto (5) aiutandosi con la chiave posta sulla maniglia.

Posizionare la maniglia (6) sull'asta comando (7).

Inserire i collarini (2) e le ghiera (1) avendo cura che gli O-Ring tenuta testa (8) non fuoriescano dalle sedi.

Tutte le O-Ring vanno inserite nelle loro sedi, dopo averle lubrificate con olio silconico.

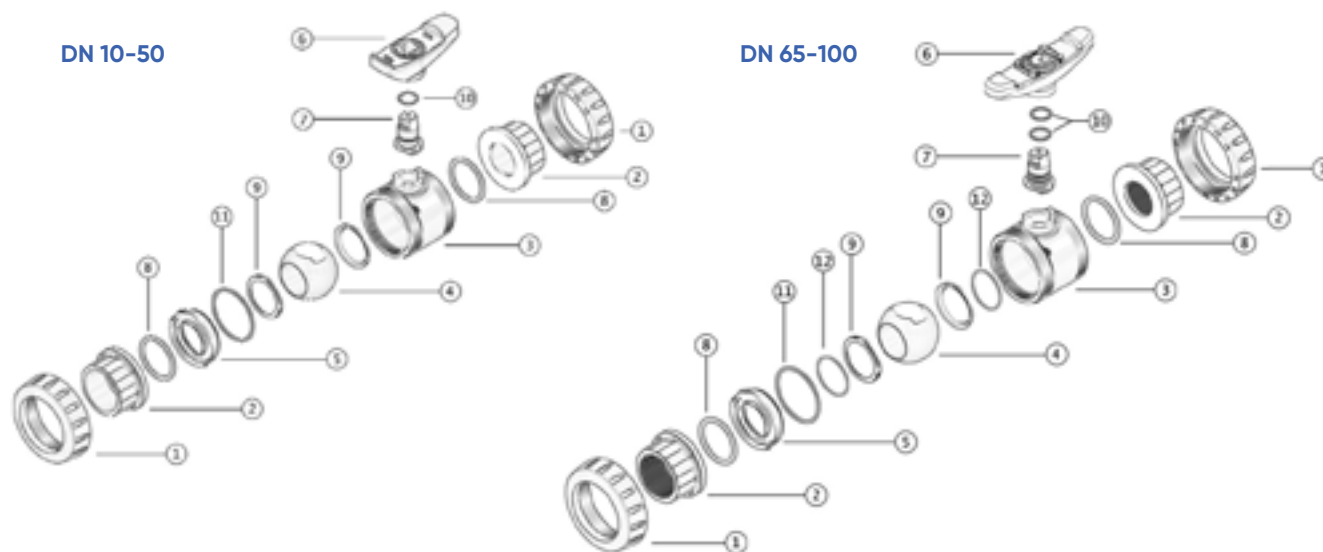

Pos.	Componenti	Materiale	n°
1	Ghiera	PVC / ABS	2
2	Collarino	PVC / ABS	2
3	Corpo	PVC / ABS	1
4	Sfera	PVC / ABS	1
5	Supporto	PVC / ABS	1
6	Maniglia	PVC	1
7	Asta comando	PVC / ABS	1
8	O-Ring tenuta testa	EPDM/FKM	2
9	Guarnizione sfera	PTFE	2
10	O-Ring asta comando	EPDM/FKM	*1
11	O-Ring tenuta radiale	EPDM/FKM	1
12	O-Ring PTFE	EPDM/FKM	**2

* N° 2 per DN 65-100 e valvola ABS

INTRODUCTION

This Instruction manual should be read before the installation and / or put into service in order to avoid damage to property or danger to people.

SYMBOLS

The following illustrations are used throughout this manual to highlight where an instruction must be followed.

INDICATION

 This symbol highlights a process that the installer / operator must follow carefully.

WARNING!

 This symbol refers to the work and instructions which must be precisely performed in order to avoid damage or destruction of the device..

DANGER!

 This symbol refers to the work and instructions which must be precisely performed in order to avoid danger to people.

TRANSPORTATION AND STORAGE

The valves should not be subject to impact or a fall that could affect the structural strength of the pressurized parts. The valves must be stored in areas with temperatures from -10° e 50°C , and should not be exposed to U.V. radiation

WARNING

 It is important to avoid rapid closure of valves to eliminate the possibility of water hammer causing damage to the pipeline

 The valve is specifically designed for water transport.

TECHNICAL DATA

TECHNICAL CHARACTERISTICS

Ball valve for industrial applications, true union, adjustable swivel support. Available versions: ISO metric (1V724 1A724) and BS standard (3V724 3A724) plain solvent weldsocket; BSP threaded socket (1V725). Available to be manufactured in other international standards (ASTM, JIS, NPT) upon request.

MATERIALS

Ball valve in grey PVC / grey ABS. Handle in red PVC. O' ring in EPDM or FPM. Ball seats in PTFE.

RANGE

Metric series from D16 up to D. 110, BSP threaded series from G 3/8" up to G 4", BS plain from D 3/8 up to D 4".

WORKING PRESSURE

PN 16 a 20°C . D16-3/8" - D63-2"
PN 10 a 20°C D75-2 1/2" - D110-4"

COMPLIANCE WITH STANDARDS

ISO metric solvent weld series to ISO 727, EN 1452/4 (PVC), complying with pipes to ISO 161/1, EN 1452/2 (PVC), EN ISO 15493.

BS solvent weld series according to BS 4346/1 (PVC), BS 5392-1 (ABS), complying with pipes to BS 3506, BS 3505 (PVC), BS 5391-1 (ABS).

BSP threaded series according to UNI ISO 228/1, DIN 2999, BS 21.

1 1V 724 / 1A 724

D	DN	L	Z	C	E	H	B	g PVC-U	g ABS
16	10	14	54	82	53	51	66	150	120
20	15	16	50	82	53	51	66	145	115
25	20	19	53	91	62	59	77	220	175
32	25	22	59	103	71	66	88	315	250
40	32	26	68	120	84	77	102	505	400
50	40	31	77	139	98	87	117	725	565
63	50	38	98	174	117	105	140	1245	970
75	65	44	142	230	168	138	225	3400	2700
90	80	51	142	244	168	138	225	3500	2800
110	100	61	162	284	210	171	280	5900	4700

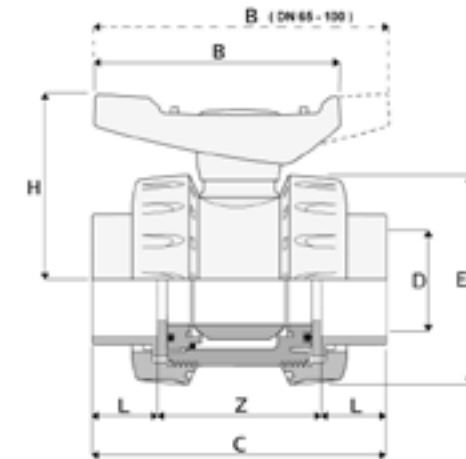

2 1V 725

D	DN	L	Z	C	E	H	B	g PVC-U
3/8"	10	13	56	82	53	51	66	150
1/2"	15	17	56	90	53	51	66	145
3/4"	20	19	55	93	62	59	77	220
1"	25	22	66	110	71	66	88	315
1 1/4"	32	24	79	127	84	77	102	505
1 1/2"	40	24	83	131	98	87	117	725
2"	50	29	103	161	117	105	140	1245
2 1/2"	65	33	164	230	168	138	225	3400
3"	80	36	172	244	168	138	225	3500
4"	100	42	200	284	210	171	280	5900

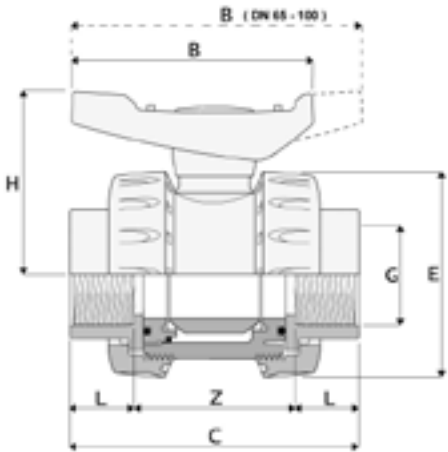
3 3V 724 / 3A 724

D	DN	L	Z	C	E	H	B	g PVC-U	g ABS
3/8"	10	15	52	82	53	51	66	150	120
1/2"	15	17	48	82	53	51	66	145	115
3/4"	20	19	53	91	62	59	77	220	175
1"	25	22	59	103	71	66	88	315	250
1 1/4"	32	26	68	120	84	77	102	505	400
1 1/2"	40	31	77	139	98	87	117	725	565
2"	50	38	98	174	117	105	140	1245	970
2 1/2"	65	44	142	230	168	138	225	3400	2700
3"	80	51	142	244	168	138	225	3500	2800
4"	100	61	162	284	210	171	280	5900	4700

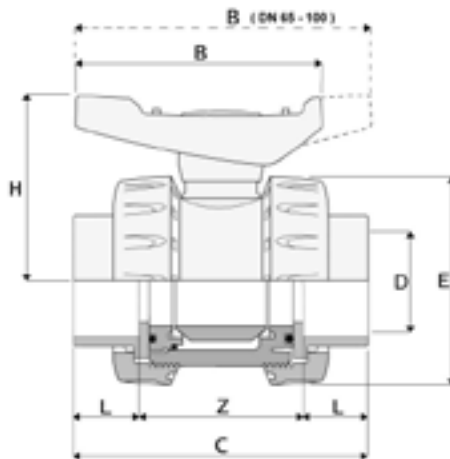

INSTALLATION INSTRUCTIONS

Ensure that the pipes are in line.

Unscrew the nuts **(1)** and fit them into the pipe ends.

Solvent weld or screw the union ends **(2)** on the pipes ends.

Position the valve between the union ends, keeping it in line, with word "reg adj" on body **(3)** upstream with respect to the direction of flow.

Lock the nut downstream with respect to the direction of flow.

Lock the other nut in correspondence with the word "reg adj" (upstream with respect to the direction of flow) until the valve is perfectly sealed.

VALVE DISASSEMBLY

Isolate the valve from the flow in the system.

Unscrew the nuts **(1)** completely and extract the valve radially. After closing the valve, remove the handle **(6)** and use it clockwise to remove the threaded the support **(5)**.

Press on the ball **(4)** from the blind side, taking care not to score it, until it comes right out of the body.

Press the stem **(7)** towards the inside of the valve body, until it comes right out.

Remove the o' rings from their seats.

VALVE ASSEMBLY

Insert the stem **(7)** from the inside of the valve body.

Place the PTFE seat **(9)** in its housing located in the valve body **(3)**. Insert the ball **(4)**. Screw the support **(5)** into the body using the key of the handle. Press the handle **(6)** on the stem **(7)**. Insert the union ends **(2)** and the nuts **(1)** taking care that the socket O-Ring don't come out of their seats.

All the O-Ring must be inserted in their seats after lubricating with silicon oil.

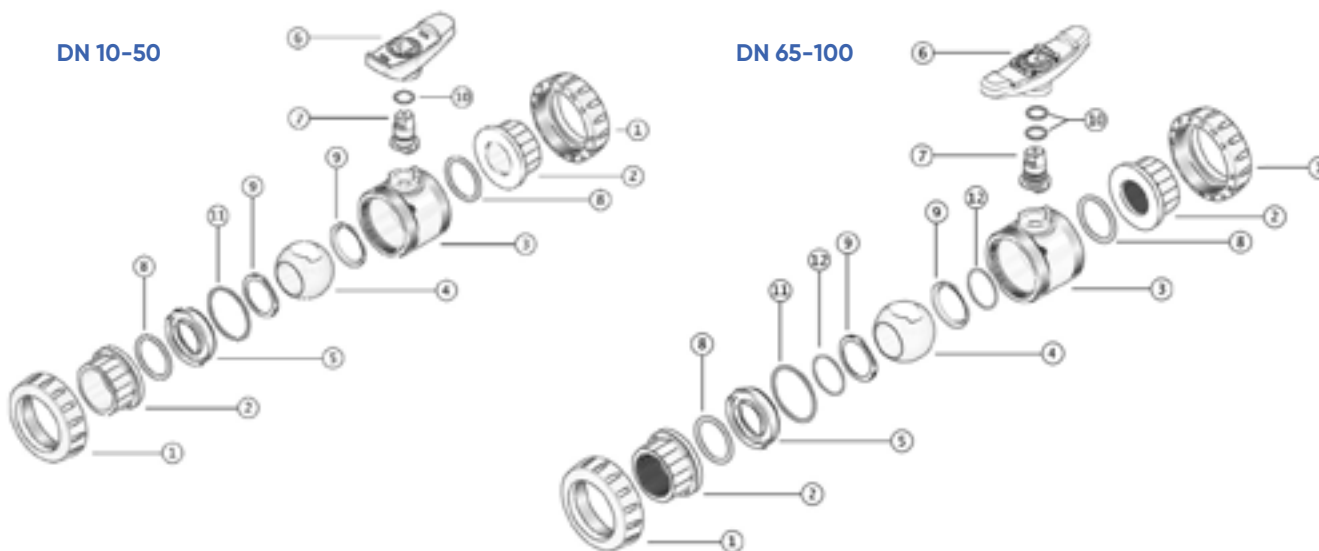

Pos.	Components	Material	n°
1	Nut	PVC / ABS	2
2	Union end	PVC / ABS	2
3	Body	PVC / ABS	1
4	Ball	PVC / ABS	1
5	Support	PVC / ABS	1
6	Handle	PVC	1
7	Stem	PVC / ABS	1
8	Socket O-Ring	EPDM/FKM	2
9	Ball seat	PTFE	2
10	Stem O-Ring	EPDM/FKM	*1
11	Body O-Ring	EPDM/FKM	1
12	O-Ring PTFE	EPDM/FKM	**2

* N° 2 for DN 65-100 and ABS valve

INTRODUCTION

Ce manuel d'instructions doit être lu avant l'installation et / ou la mise en service afin d'éviter des dommages matériels ou la mise en danger des personnes.

SYMBOLES

Les illustrations suivantes sont utilisées dans ce manuel comme symboles et notifications d'avertissement.

INDICATION

 Ce symbole indique une indication que l'installateur ou l'exploitant doit suivre attentivement.

ATTENTION !

 Ce symbole fait référence à des tâches et instructions qui doivent être réalisées et suivies précisément afin d'éviter des dommages ou la destruction du produit.

DANGER !

 Ce symbole fait référence à des tâches et instructions qui doivent être réalisées et suivies précisément pour éviter toute mise en danger des personnes.

TRANSPORT ET STOCKAGE

Les vannes ne doivent pas être soumises à des chocs ou une chute qui pourraient affecter la résistance structurelle des parties sous pression. Les vannes doivent être entreposées à des températures entre -10°C et 50°C , et ne doivent pas être exposées au rayonnement UV.

ATTENTION

 Il est important d'éviter la fermeture trop rapide des vannes du fait des coups bélier et il est recommandé de protéger vanne contre les manoeuvres accidentelles.

 La vanne est spécialement conçue pour le transport par eau.

DONNÉES TECHNIQUE

TECHNICAL CHARACTERISTICS

Robinet à tournant sphérique pour application industrielle, double anneaux à démontage radial, avec support réglable sur sphère ronde. Versions disponibles pour collage femelle ISO métrique (1V724 1A724) et BS standard (3V724 3A724), filetage femelle BSP (1V725). Sur demande, possibilité d'executions dans d'autres standards internationaux (ASTM, JIS, NPT).

MATERIAUX

Vanne en Pvc gris / ABS gris, poignée en PVC rouge, joints d'étanchéité en EPDM ou FPM, siège de la sphère en PTFE.

GAMMA

Série métrique de D16 à D110, série fileté BSP de G 3/8" à G4", série BS pour encollage de D 3/8" à D 2".

CONDITIONS DE FONCTIONNEMENT

PN 16 à 20°C . D16-3/8" - D63-2"
PN 10 à 20°C D75-2 1/2" - D110-4"

NORME DE RÉFÉRENCE

Série des joints ISO métrique pour collage selon ISO 727, EN 1452/4 (PVC), pouvant être accouplés aux tuyaux conformes aux normes ISO 161/1 en 1452/2 (PVC), EN ISO 15493.

Série des joints BS pour collage selon BS 4346/1 (PVC), BS 5392-1 (ABS), pouvant être accouplés aux tuyaux conformes aux normes BS 3506, BS 3505 (PVC), BS 5391-1 (ABS).

Série des joints filetés BSP selon UNI ISO 228/1, DIN 2999, BS 21.

1 1V 724 / 1A 724

D	DN	L	Z	C	E	H	B	g PVC-U	g ABS
16	10	14	54	82	53	51	66	150	120
20	15	16	50	82	53	51	66	145	115
25	20	19	53	91	62	59	77	220	175
32	25	22	59	103	71	66	88	315	250
40	32	26	68	120	84	77	102	505	400
50	40	31	77	139	98	87	117	725	565
63	50	38	98	174	117	105	140	1245	970
75	65	44	142	230	168	138	225	3400	2700
90	80	51	142	244	168	138	225	3500	2800
110	100	61	162	284	210	171	280	5900	4700

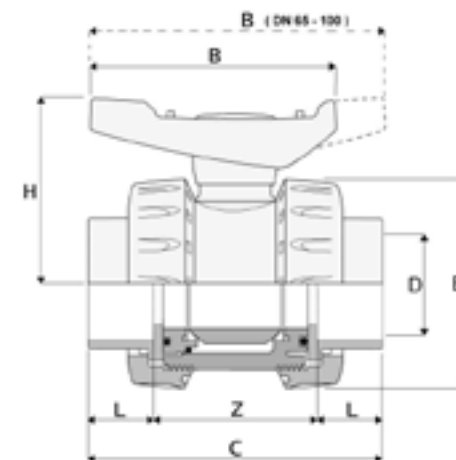

2 1V 725

D	DN	L	Z	C	E	H	B	g PVC-U
3/8"	10	13	56	82	53	51	66	150
1/2"	15	17	56	90	53	51	66	145
3/4"	20	19	55	93	62	59	77	220
1"	25	22	66	110	71	66	88	315
1 1/4"	32	24	79	127	84	77	102	505
1 1/2"	40	24	83	131	98	87	117	725
2"	50	29	103	161	117	105	140	1245
2 1/2"	65	33	164	230	168	138	225	3400
3"	80	36	172	244	168	138	225	3500
4"	100	42	200	284	210	171	280	5900

3 3V 724 / 3A 724

D	DN	L	Z	C	E	H	B	g PVC-U	g ABS
3/8"	10	15	52	82	53	51	66	150	120
1/2"	15	17	48	82	53	51	66	145	115
3/4"	20	19	53	91	62	59	77	220	175
1"	25	22	59	103	71	66	88	315	250
1 1/4"	32	26	68	120	84	77	102	505	400
1 1/2"	40	31	77	139	98	87	117	725	565
2"	50	38	98	174	117	105	140	1245	970
2 1/2"	65	44	142	230	168	138	225	3400	2700
3"	80	51	142	244	168	138	225	3500	2800
4"	100	61	162	284	210	171	280	5900	4700

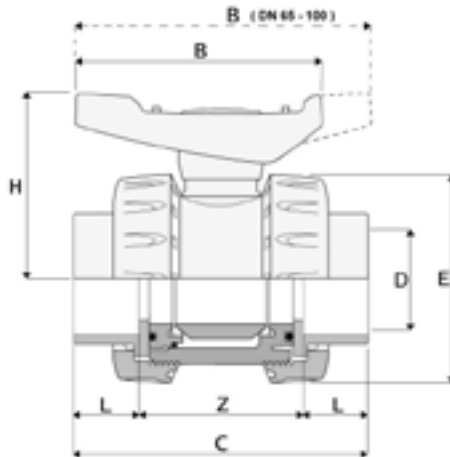
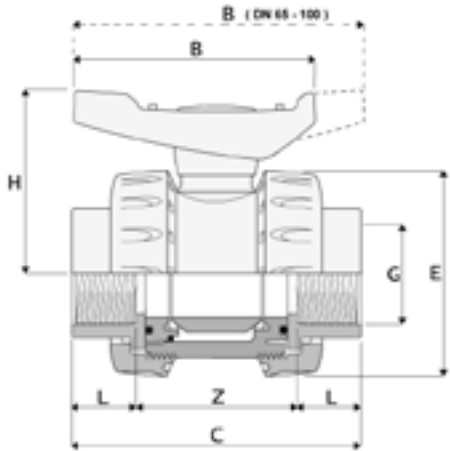

INSTRUCTIONS D'INSTALLATION

S'assurer que les tuyauteries soient alignées.

Devissier les écrous **(1)**, avant de les enfiler sur les extrémités du tube. Procéder à l'encollage ou vissez le collets **(2)** sur les tubes. Positionner la vanne entre les collets, tout en maintenant alignée et en plaçant l'indication "reg. adj", située sur le corps **(3)**, en amont de la direction du flux.

Serrer l'écrou en aval de la direction du flux.

Serrer l'autre écrou en face de l'indication "reg. adj" (en amont de la direction du flux) jusqu'à ce que la vanne soit complètement étanchée.

DÉMONTAGE DE LA VANNE

Isoler la vanne du flux présent dans l'installation.

Dévisser complètement les écrous **(1)** et extraire la vanne suivant la rayon.

Après avoir mis le robinet en position de fermeture, extraire le volant **(6)** et l'utiliser pour enter le support fleté **(5)** en tournant dans le sens contraire des aiguilles d'une montre.

Presser sur la sphère **(4)** du cône aveugle, en faisant attention de ne pas l'endommager, jusqu'à ce qu'elle soit complètement sortie du corps.

Premer sur la tige de commande **(7)** vers l'intérieur du corps de la vanne, jusqu'à ce qu'elle soit sortie.

Extraire les joints.

MONTAGE DE LA VANNE

Insérez la tige de manoeuvre **(7)** dans le corps en passant par l'intérieur. Insérez la siége en PTFE **(9)** dans la siége du corps **(3)**. Insérez la sphere **(4)**. Visser le support **(5)** dans le corps en utilisant la clé insérée sur le volant.

Positionner le volant **(6)** sur la tige de manoeuvre **(7)**.

Insérez les collets **(2)** et les écrous **(1)** de que les joints des collets **(8)** ne sortent pas de leur logement.

Tous les O-Rings doivent naturellement être insérés dans leur logement après les siliconer.

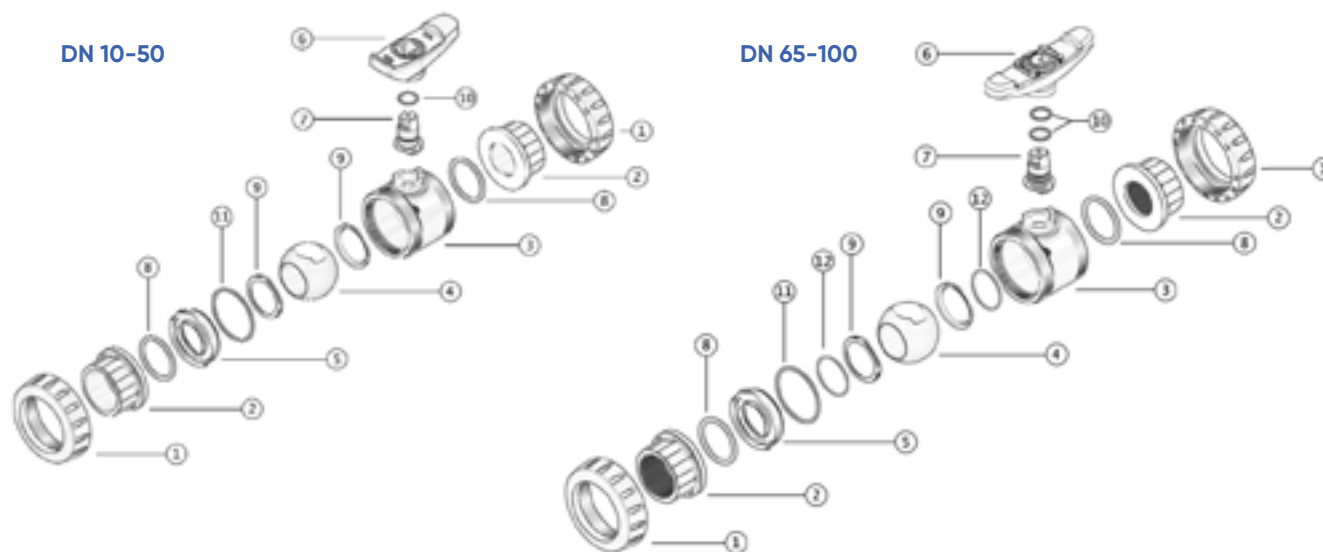

Pos.	Composants	Material	n°
1	Ecrou	PVC / ABS	2
2	Collet	PVC / ABS	2
3	Corp	PVC / ABS	1
4	Sphere	PVC / ABS	1
5	Support	PVC / ABS	1
6	Volant	PVC	1
7	Tige	PVC / ABS	1
8	Joint du collet	EPDM/FKM	2
9	Siege	PTFE	2
10	Joint de la tige	EPDM/FKM	*1
11	Joint du corp	EPDM/FKM	1
12	O-Ring PTFE	EPDM/FKM	**2

* N° 2 pour DN 65-100 et vanne ABS

EINLEITUNG

Um Schäden an der Armatur und einer mögliche Gefährdung von Personen zu vermeiden, ist die Bedienungsanleitung vor der Montage oder der Inbetriebnahme sorgfältig zu lesen.

GEFAHRENHINWEISE

Mit den nachstehenden Gefahrenhinweisen wird auf Gefährdungen, Risiken und sicherheitsrelevante Informationen durch eine hervorgehobene Darstellung besonders hingewiesen

HINWEIS

 Hinweise, die mit diesem Gefahrensymbol gekennzeichnet sind, werden auf eine besondere Sorgfaltspflicht für den Installateur und Betreiber hin.

ACHTUNG!

 Hinweise die mit diesem Gefahrensymbol gekennzeichnet sind, beschreiben Verhaltensmassnahmen deren Nichtbeachtung zur Beschädigung oder vollständigen Zerstörung der Armatur führen können.

GEFAHR!

 Hinweise, die mit diesem Gefahrensymbol gekennzeichnet sind, beschreiben Verhaltensmassnahmen deren Nichtbeachtung zu schweren Verletzungen oder Lebensgefahr für Anwender oder Dritte führen können.

LAGERUNG UND TRANSPORT

Die Armaturen sind gegen äussere Gewalt (wie Stoss, Schlag, Vibration) zu schützen. Die Armaturen sind vor der Einwirkung materialschädigender UVStrahlung geschützt zu lagern. Während der Lagerung sind die maximal zulässigen Temperaturgrenzen von -10 °C bis 50 °C einzuhalten.

WARNUNG

 Um Wasserschläge zu vermeiden dürfen Armaturen nicht rasch geschlossen werden, die Armaturen müssen auch vor zufälligen Betätigungen geschützt werden.

 Das Ventil ist speziell für den Wassertransport konzipiert.

BETRIEBSDATEN

TECHNISCHE EIGENSCHAFTEN

Kugelventil für industrielle Anwendungen, Zweifach-Oberwurfmutter mit Radialausbau, auf der runder Kugel befindet sich ein verstellbares Lager. Ausführungen für metrische Nut-Klebeverbindung ISO (1V724/1A724) und BS Standard (3V724/3A724), Innengewinde BSP (1W25) sind verfügbar. Auf Anfrage sind Ausführungen in anderen internationalen Standards (ASTM, JIS, NPT) möglich.

MATÉRIALEN

Ventil aus grauem PVC / grauem ABS, Hand-griff aus rotem PVC, Dichtungen aus EPDM oder FPM, Kugelsitze aus PTFE.

SORTIMENT

Metrische Reihe von D 16 bis D 110, Gewindereihe BSP von G 3/8" bis G 4, BS Standardreihe von D 3/8" bis D 4".

WIDERSTAND ZUM DRUCK

PN 16 a 20 °C . D16-3/8" - D63-2"
PN 10 a 20 °C D75-2 1/2" - D110-4"

NORMVORSCHRIFTEN

Metrische Reihe für Klebeverbindung ISO gemäß ISO 727, EN 1452/4 (PVC), verbindbar mit Rohren gemäß ISO 161/1, EN 1452/2 (PVC), EN ISO 15493.

BS Reihe Klebeverbindung gemäß BS 4346/1 (PVC), BS 5392-1 (ABS), verbindbar mit Rohren gemäß BS 3506, BS 3505 (PVC), BS 5391-1 (ABS).

Gewindereihe für Verbindung BSP gemäß UNI ISO 228/1, DIN 2999, BS 21.

1 1V 724 / 1A 724

D	DN	L	Z	C	E	H	B	g PVC-U	g ABS
16	10	14	54	82	53	51	66	150	120
20	15	16	50	82	53	51	66	145	115
25	20	19	53	91	62	59	77	220	175
32	25	22	59	103	71	66	88	315	250
40	32	26	68	120	84	77	102	505	400
50	40	31	77	139	98	87	117	725	565
63	50	38	98	174	117	105	140	1245	970
75	65	44	142	230	168	138	225	3400	2700
90	80	51	142	244	168	138	225	3500	2800
110	100	61	162	284	210	171	280	5900	4700

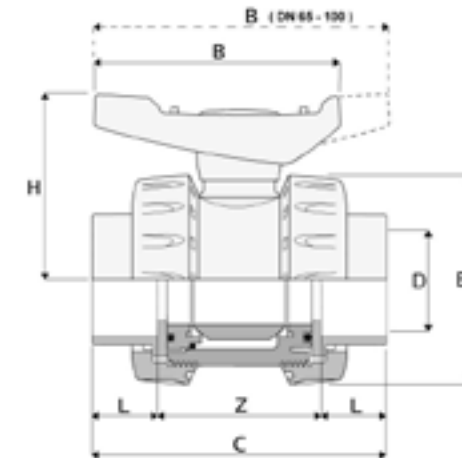

2 1V 725

D	DN	L	Z	C	E	H	B	g PVC-U
3/8"	10	13	56	82	53	51	66	150
1/2"	15	17	56	90	53	51	66	145
3/4"	20	19	55	93	62	59	77	220
1"	25	22	66	110	71	66	88	315
1 1/4"	32	24	79	127	84	77	102	505
1 1/2"	40	24	83	131	98	87	117	725
2"	50	29	103	161	117	105	140	1245
2 1/2"	65	33	164	230	168	138	225	3400
3"	80	36	172	244	168	138	225	3500
4"	100	42	200	284	210	171	280	5900

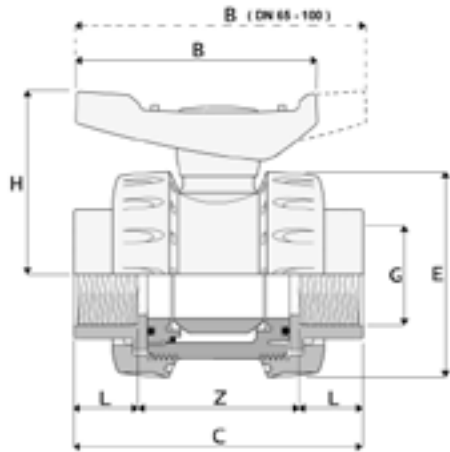
3 3V 724 / 3A 724

D	DN	L	Z	C	E	H	B	g PVC-U	g ABS
3/8"	10	15	52	82	53	51	66	150	120
1/2"	15	17	48	82	53	51	66	145	115
3/4"	20	19	53	91	62	59	77	220	175
1"	25	22	59	103	71	66	88	315	250
1 1/4"	32	26	68	120	84	77	102	505	400
1 1/2"	40	31	77	139	98	87	117	725	565
2"	50	38	98	174	117	105	140	1245	970
2 1/2"	65	44	142	230	168	138	225	3400	2700
3"	80	51	142	244	168	138	225	3500	2800
4"	100	61	162	284	210	171	280	5900	4700

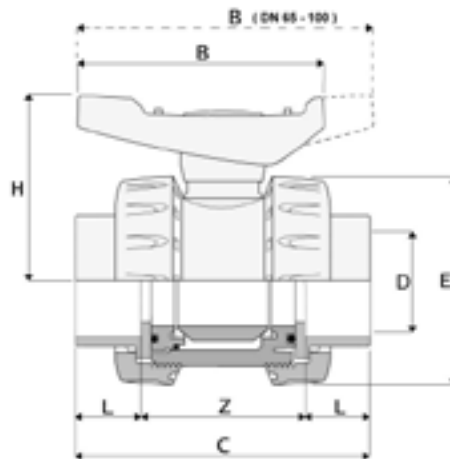

INSTALLATIONSANWEISUNGEN

Sicherstellen, daß die Rohrleitungen ausgerichtet sind. Die Oberwurfmutter (1) abschrauben und in die Rohrenden einführen. Die beiden Anschlußteile (2) werden auf die Rohrleitung geklebt oder aufgeschraubt. Das Ventil, korrekt ausgerichtet, zwischen die Muffen montieren, wobei die Schrift "reg adj." auf dem Ventilkörper (3) vor der Durchflussrichtung liegen muss. Die Oberwurfmutter hinter der Durchflussrichtung liegen. Die andere Oberwurfmutter wird in Obereinstimmung mit der Schriftzug, "reg. adj.", (vor der Durchflussrichtung) bis zur Erreichung der perfekten Dichtigkeit des Ventils positioniert.

VENTIL DEMONTAGE

Das Ventil vom Durchfluss in der Anlage isolieren. Die Oberwurfmutter (1) vollständig abschrauben und das Ventil radiell herausziehen. Nachdem das Ventil (6) in Schließungsposition gestellt wird, nehmen Sie den Handgriff und benutzen Sie zur Abschraubung der gewindeten Dichtungsträger (5) (rechts). An der blinden Seite (4) auf die Kugel drücken, so daß sie nicht beschädigt wird und vollständig aus dem Körper herauskommt. In Richtung Ventilinneres so lange auf die Spindel (7) drücken, bis sie aus dem Ventil austritt. Die Dichtungen aus ihren Sitzen entfernen.

VENTIL MONTAGE

Die Spindel (7) von der Innenseite des Gehäuses einsetzen. Die PTFE- Dichtung (9) ist in das Gehäuse (3) einlegen. Die Kugel (4) montieren. Der Dichtungsträger (5) mit dem Handgriffschlüssel ins Gehäuse einschrauben. Der Handgriff (6) wird auf die Spindel befestigt (7). Die Anschlußteile (2) und die Oberwurfmutter (1) montieren, sodaß die O-Ringe (8) bei der Montage in die entsprechenden Sitze bleiben. Alle O-Ringe massen in ihren Sitzen eingesetzt werden, nachdem sie mit Silikonöl geschmiert werden

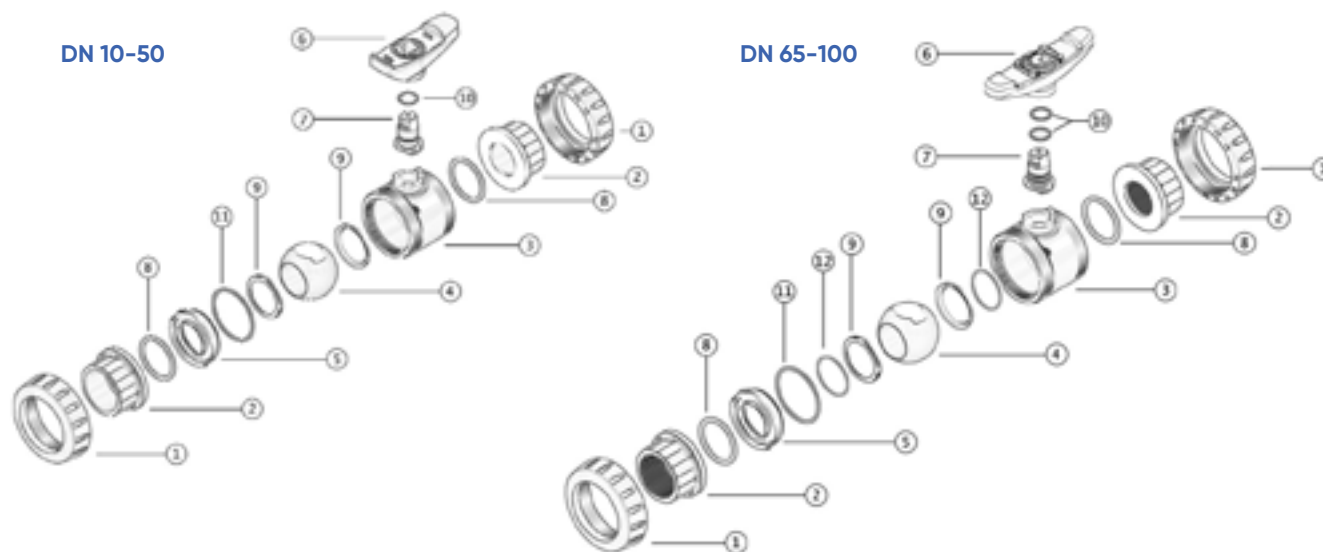

Pos.	Benennung	Material	n°
1	Überwurfmutter	PVC / ABS	2
2	Anschlußteil	PVC / ABS	2
3	Gehäuse	PVC / ABS	1
4	Kugel	PVC / ABS	1
5	Dichtungsträger	PVC / ABS	1
6	Handgriff	PVC	1
7	Spindel	PVC / ABS	1
8	O-Ring	EPDM/FKM	2
9	Kugeldichtung	PTFE	2
10	O-Ring	EPDM/FKM	*1
11	O-Ring	EPDM/FKM	1
12	O-ring PTFE	EPDM/FKM	**2

* Nr. 2 für DN 65-100 und ABS-Ventil