

MEASUREMENT AND INSTRUMENTATION FLS

The FLS Measurement and Instrumentation line consists of a comprehensive range of Flow, pH, ORP, Conductivity Sensors, Monitors and Transmitters.



Enter

INDEX

SYSTEM SELECTION GUIDE	3
APPLICATIONS TABLE	4
FLS PRODUCTS COMPATIBILITY CHART	6
1. MONITORS FOR FLOW, pH/ORP, CONDUCTIVITY MEASUREMENT AND CONTROL	
Instruments Technical Features	10
Installation and Dimensions	11
FLS M9.02 Flow Monitor & Transmitter	12
FLS M9.00 2-Wires Flow Monitor & Transmitter	15
FLS M9.20 Battery Powered Flow Monitor	18
FLS M9.50 Batch Controller	21
FLS M9.05 Conductivity Monitor & Transmitter	24
FLS M9.06 pH/ORP Monitor & Transmitter	27
FLS M9.03 Dual-Parameter Flow Monitor & Transmitter	30
FLS M9.07 Dual-Parameter Conductivity and Flow Monitor & Transmitter	33
FLS M9.08 Dual-Parameter pH/ORP and Flow Monitor & Transmitter	36
FLS M9.10 Dual-Parameter Analog Monitor & Transmitter	39
2. INSERTION PADDLEWHEEL AND ELECTROMAGNETIC FLOW SENSORS	
FLS F3.00 Paddlewheel Flow Sensor	44
FLS F3.20 High Pressure Paddlewheel Flow Sensor.....	51
FLS F6.30 Paddlewheel Flow Transmitter.....	54
FLS F3.10 Mini Paddlewheel Flow Sensor.....	58
FLS F3.05 Paddlewheel Flow Switch	61
FLS F6.60 Magmeter Flow Sensor.....	65
FLS F6.61 Hot Tap Magmeter Flow Sensor	68
<i>Installation & Operating Guidelines for Insertion Flow Sensors</i>	72
3. IN LINE ULTRA LOW FLOW AND OVAL GEAR SENSORS	
FLS ULF Ultra Low Flow Sensor	78
FLS F3.80 Oval Gear Flow Sensor.....	82
<i>Installation & Operating Guidelines for In line Flow Sensors</i>	87
4. BULB AND FLAT pH/ORP ELECTRODES WITH EPOXY, C-PVC, RYTON OR GLASS BODY	
FLS pH/ORP 200 Epoxy body Bulb Electrode	90
FLS pH/ORP 400 Glass body Bulb Electrode	93
FLS pH/ORP 600 C-PVC body Flat Surface Electrode	96
FLS pH 800 Ryton Body Flat Surface Electrode	101
<i>Installation & Operating Guidelines for pH/ORP Electrodes</i>	105

5. POTENTIOMETRIC AND INDUCTIVE CONDUCTIVITY SENSORS

FLS C150-200 Graphite or Platinum Conductivity Sensor	108
FLS C100-300 Stainless Steel Conductivity Sensor.....	111
FLS C6.30 Inductive Conductivity Transmitter.....	114
<i>Installation & Operating Guidelines for Conductivity Sensors</i>	<i>118</i>

6. MISCELLANEA

FLS HF6 Level and Pressure Transmitter	120
<i>Installation & Operating Guidelines for Miscellaneous Instruments</i>	<i>125</i>

7. INSTALLATION FITTINGS FOR FLOW SENSORS AND ANALYTICAL ELECTRODES

Standard Insertion Installation	128
Hot Tap Insertion Installation.....	144
Specific adapters for Analytical Electrodes Installation.....	146

8. SPARE PARTS AND ACCESSORIES FOR MONITORS, FLOW SENSORS AND ANALYTICAL ELECTRODES

Spare Parts	150
Accessories.....	153

9. TECHNICAL INFORMATION

Flow measurement	156
Analytical measurement.....	163
Miscellanea measurement	171

The data given in this leaflet are offered in good faith. No liability can be accepted concerning technical data that are not directly covered by recognized international standards. FIP-FLS reserves the right to carry out any modification to the products shown in this leaflet.

Installation and maintenance operations should be made by professionals.

SYSTEM SELECTION GUIDE

HOW TO CHOOSE THE MEASURING SYSTEM

The present section gives suggestions to select the proper instruments according to your specific liquids and applications.

1

DEFINE THE WORKING CONDITIONS

Clarifying the following data is critical to make the proper system choices and to get the best performances.

- Type of measurement
- Range of measurement
- Pipe material, size and standard
- Media (for chemical compatibility evaluation)
- Temperature & Pressure required
- Performances required
- Presence of solids
- Liquid viscosity

2

CHOOSE THE SENSOR TECHNOLOGY

Looking at the Application Table is possible to determine which sensor family can be applied to your specific process. In case you are interested to deepen, you can also refer to the Technical Information section for additional information.

3

CHOOSE THE INSTRUMENT

Look at the FLS Products Compatibility Chart for an overview of all the possible sensor-monitor-transmitter combinations. Different input/output options, different visualization options and different installation options are available to perfectly fit your process needs.

4

DEFINE THE INSTALLATION CONDITIONS

The last step is related to the process connection: a wide range of fittings and accessories is available for the installation on different pipe sizes and materials as well as for hot tap or submersible installations.

APPLICATIONS TABLE

PRODUCT SELECTION GUIDE BY LIQUID/OPERATIVE CONDITIONS

FLS Insertion Paddlewheel and Electromagnetic Flow Sensors							
	F3.00	F3.20	F6.30	F3.10	F3.05	F6.60	F6.61
clean liquid	1	1	1	1	1	1	1
dirty liquid	3	3	3	3	3	1	1
low viscous liquid	2	2	2	3	2	2	2
high viscous liquid	3	3	3	3	2	3	3
low corrosive liquid	1	1	1	2	1	1	1
high corrosive liquid	1	2	1	3	1	2	2
fibrous slurry	3	3	3	3	3	1	1
abrasive slurry	3	3	3	3	3	1	1
no conductive liquid	1	1	1	1	1	3	3
pulsating flow	3	3	3	3	3	3	3
high temperature	1	1	2	3	1	1	2
high pressure	2	1	2	3	2	3	2
big pipes	3	3	3	3	3	3	1

	FLS In line Ultra low Flow and Oval Gear Sensors		FLS Bulb and Flat pH/ORP Electrodes				FLS Potentiometric and Inductive Conductivity Sensors		
	ULF	F3.80	pH/ORP 200	pH/ORP 400	pH/ORP 600	pH 800	C150-200	C100-300	C6.30
clean liquid	1	1	1	1	1	1	1	1	1
dirty liquid	3	3	2	3	1	1	2	1	1
low viscous liquid	2	1	2	2	2	1	2	1	1
high viscous liquid	3	1	3	3	3	2	3	2	1
low corrosive liquid	1	1	1	1	1	1	3	2	1
high corrosive liquid	1	1	2	2	1	1	3	3	1
fibrous slurry	3	3	2	3	1	1	3	1	1
abrasive slurry	3	3	2	3	2	1	3	2	1
no conductive liquid	1	1	3	1	2	2	3	1	3
pulsating flow	3	2	1	1	1	1	1	1	1
high temperature	2	3	3	1	2	2	3	2	3
high pressure	3	3	2	1	2	2	2	2	3
big pipes	3	3	3	2	1	2	3	3	3

LEGENDA

- 1 = Generally Suitable
- 2 = Worth Consideration
- 3 = Unsuitable

PRODUCT SELECTION GUIDE BY PROCESS/MARKET

FLS Insertion Paddlewheel and Electromagnetic Flow Sensors							
	F3.00	F3.20	F6.30	F3.10	F3.05	F6.60	F6.61
fertigation / agriculture	■			■			
swimming pool & SPAs	■		■				
waste water treatment						■	
water and pure water treatment	■	■	■				
food & beverages						■	
water distribution & leak detection							■
sewage						■	■
mining slurries						■	■
dosing system							
pump protection					■		
HVAC & Heat exchangers	■	■	■				
detergents/disinfectant production & dosing						■	
metal finishing/ textile process						■	

	FLS In line Ultra low Flow and Oval Gear Sensors		FLS Bulb and Flat pH/ORP Electrodes				FLS Potentiometric and Inductive Conductivity Sensors		
	ULF	F3.80	pH/ORP 200	pH/ORP 400	pH/ORP 600	pH 800	C150-200	C100-300	C6.30
fertigation / agriculture			■					■	
swimming pool & SPAs			■				■		
waste water treatment					■	■		■	
water and pure water treatment				■				■	
food & beverages				■			■		
water distribution & leak detection									
sewage					■	■			■
mining slurries					■	■			■
dosing system	■	■				■			
pump protection									
HVAC & Heat exchangers			■				■		
detergents/disinfectant production & dosing	■	■		■			■		
metal finishing/textile process				■				■	

LEGENDA

■ = Best cost effective option

FLS PRODUCTS COMPATIBILITY CHART

FLS Insertion Paddlewheel and Electromagnetic Flow Sensors compatibility with FLS Instruments

	M9.02	M9.00	M9.20	M9.50	M9.05	M9.06	M9.03	M9.07	M9.08	M9.10
F3.00 Paddlewheel Flow Sensor	■ (H version)	■ (H version)	■ (only coil version)	■ (only H version)			■ (H version)	■ (H version)	■ (H version)	■ (H version)
F3.20 High pressure Paddlewheel Flow Sensor	■	■		■			■	■	■	■
F6.30 Paddlewheel Flow Transmitter										■
F3.10 Mini Paddlewheel Flow Sensor	■	■		■			■	■	■	■
F3.05 Paddlewheel Flow switch										
F6.60 Magmeter Flow Sensor	■			■			■	■	■	■
F6.61 Hot Tap Magmeter Flow Sensor	■			■			■	■	■	

In Line Ultra Low Flow and Oval Gear Sensors compatibility with FLS Instruments

	M9.02	M9.00	M9.20	M9.50	M9.05	M9.06	M9.03	M9.07	M9.08	M9.10
ULF Ultra Low Flow sensor	■ (H version)	■ (only reed version)	■ (only reed version)	■ (H version)			■ (H version)	■ (H version)	■ (H version)	■ (H version)
F3.80 Oval Gear Flow sensor	■			■			■	■	■	■

Bulb and Flat pH/ORP Electrodes										
	M9.02	M9.00	M9.20	M9.50	M9.05	M9.06	M9.03	M9.07	M9.08	M9.10
pH/ORP 200 Epoxy body Bulb electrodes						■			■	
pH/ORP 400 Glass body Bulb electrodes						■			■	
pH/ORP 600 C-PVC Body Flat Surface electrodes						■			■	
pH 800 Ryton Body Flat Surface electrodes						■			■	

Potentiometric and Inductive Conductivity Sensors										
	M9.02	M9.00	M9.20	M9.50	M9.05	M9.06	M9.03	M9.07	M9.08	M9.10
C150-200 Graphite or Platinum Conductivity sensors					■			■		
C100-300 C-PVC Stainless steel Conductivity sensors					■			■		
C6.30 Inductive Conductivity transmitter										■

Miscellanea										
	M9.02	M9.00	M9.20	M9.50	M9.05	M9.06	M9.03	M9.07	M9.08	M9.10
HF6 Level and Pressure Transmitter										■



MONITORS FOR FLOW, pH/ORP,
CONDUCTIVITY MEASUREMENT
AND CONTROL

**HIGH VISIBLE SCREEN
AND QUICK CALIBRATION SYSTEM
FOR MAXIMISED PERFORMANCES**

INSTRUMENTS TECHNICAL FEATURES

Single Parameter					
	Digital Outputs	Analog Outputs	Relay Outputs	Power Supply	Mounting
M9.02 Flow Monitor and Transmitter	2 * Solid State Relays	1 * 4-20mA	1 * mechanical relay	24VDC/220VAC	Compact/Panel/Wall
M9.00 2-Wires Flow Monitor and Transmitter	1 * Solid State Relay	1 * 4-20mA	-	24VDC/220VAC	Compact/Panel/Wall
M9.20 Battery Powered Flow Monitor	-	-	-	-	Compact/Panel/Wall
M9.05 Conductivity Monitor and Transmitter	2 * Solid State Relays	2 * 4-20mA	2 * mechanical relays	24VDC/220VAC	Panel/Wall
M9.06 pH/ORP Monitor and Transmitter	2 * Solid State Relays	2 * 4-20mA	2 * mechanical relays	24VDC/220VAC	Panel/Wall

Dual Parameter					
	Digital Outputs	Analog Outputs	Relay Outputs	Power Supply	Mounting
M9.03 Dual-Parameter Flow Monitor & Transmitter	2 * Solid State Relays	2 * 4-20mA	2 * mechanical relays	24VDC/220VAC	Panel/Wall
M9.07 Dual-Parameter Conductivity and Flow Monitor and Transmitter	2 * Solid State Relays	2 * 4-20mA	2 * mechanical relays	24VDC/220VAC	Panel/Wall
M9.08 Dual-Parameter pH/ORP and Flow Monitor & Transmitter	2 * Solid State Relays	2 * 4-20mA	2 * mechanical relays	24VDC/220VAC	Panel/Wall
M9.10 Dual-Parameter Analog Monitor and Transmitter	2 * Solid State Relays	2 * 4-20mA	2 * mechanical relays	24VDC/220VAC	Panel/Wall

INSTALLATION AND DIMENSIONS

COMPACT MOUNTING - FOR M9.02, M9.00 AND M9.20

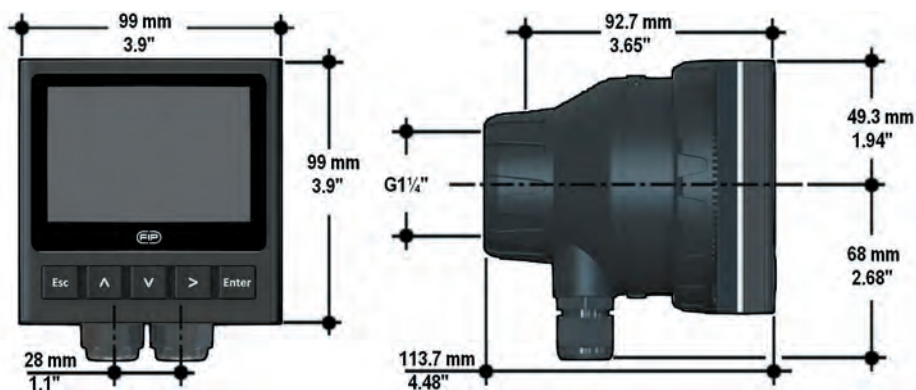

PANEL MOUNTING - FOR M9.02, M9.00 AND M9.20

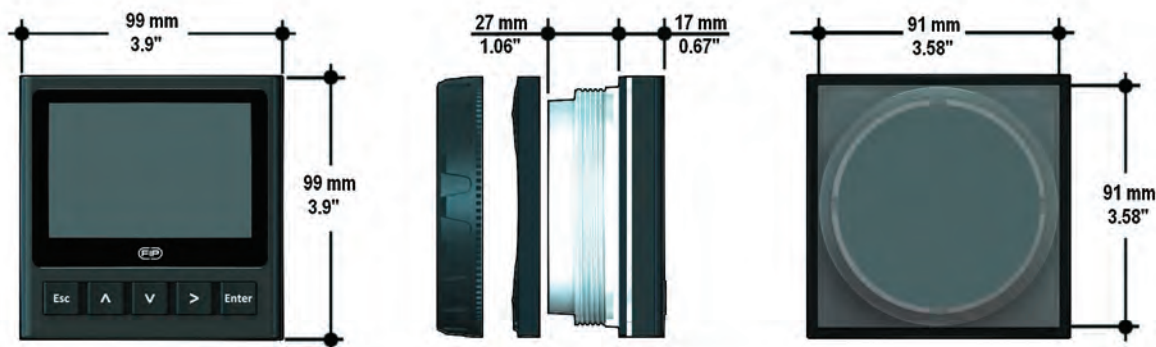

PANEL MOUNTING - ALL MONITORS EXCEPT M9.02, M9.00 AND M9.20

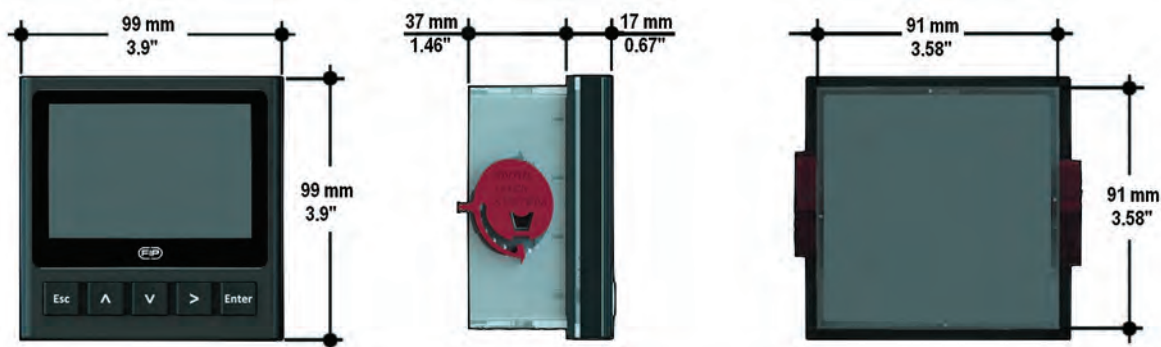

WALL MOUNTING

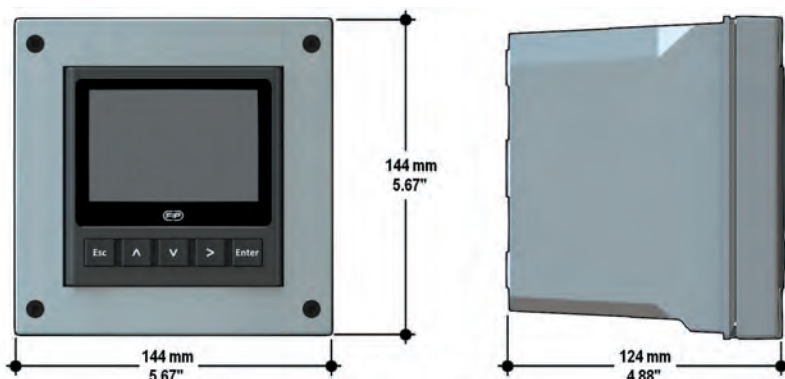

FLS M9.02

FLOW MONITOR & TRANSMITTER



The new FLS M9.02 is a powerful flow monitor designed to convert the frequency signal of FLS flow sensors into a flow rate. M9.02 is equipped with a wide full graphic display 4" which shows measured values clearly and a lot of other useful information. Moreover, due to a multicolor display plus a powerful backlight, measurement status can be determined easily from afar also. A tutorial software guarantees a mistake-proof and fast set up of every parameters. Calibration can be performed just fixing installation features or using a reference value through a new "in-line calibration". A 4-20mA output is available to remote flow rate to a external device. A proper combination of digital outputs allows customized setups for any process to be controlled. The USB port on the rear part allows the upgrade of software offering a wide range of customization services both standard and on request.

APPLICATIONS

- Water treatment systems
- Industrial waste water treatment and recovery
- Water distribution
- Filtration systems
- Swimming pools & SPA
- Irrigation & Fertigation
- Leak detection
- Cooling water monitoring
- Processing and manufacturing industry
- Chemical production

MAIN FEATURES

- Wide full graphic display
- Multicolor backlight
- Help on board
- Installation flexibility
- Fast, intuitive and mistake-proof calibration software
- Mechanical relay for external device control
- Solid State Relays for programmable alarms
- Multilanguage menu
- USB port for software upgrading



TECHNICAL DATA

General

- Associated sensors: FLS hall effect flow sensors with frequency output or FLS F6.60 Flow sensor magmeters
- Materials:
 - Case: ABS
 - Display window: PC
 - Panel & Wall gasket: silicone rubber
 - Keypad: 5-button silicone rubber
- Display:
 - LC full graphic display
 - Backlight version: 3-colours
 - Backlight activation: User adjustable with 5 levels of timing
 - Update rate: 1 second
- Enclosure: IP65 front
- Flow input range (frequency): 0÷1500Hz
- Flow input accuracy (frequency): 0,5%

Electrical

- Supply Voltage: 12 to 24 VDC ± 10% regulated
- Max Power Consumption: < 200 mA
- FLS hall effect flow Sensor power:
 - 5 VDC @ < 20 mA
 - Optically isolated from current loop
 - Short circuit protected
- 1*Current output:
 - 4-20 mA, isolated, fully adjustable and reversible
 - Max loop impedance: 800 Ω @ 24 VDC - 250 Ω @ 12 VDC
- 2*Solid State Relay output:
 - User selectable as MIN alarm, MAX alarm, Pulse Out, Window alarm, Off
 - Optically isolated, 50 mA MAX sink, 24 VDC MAX pull-up voltage
 - Max pulse/min: 300

- Hysteresis: User selectable
- 1*Relay output:
 - User selectable as MIN alarm, MAX alarm, Pulse Out, Window alarm, Off
 - Mechanical SPDT contact
 - Expected mechanical life (min. operations): 10⁷
 - Expected electrical life (min. operations): 10⁵ N.O./N.C.switching capacity 5A/240VAC
 - Max pulse/min: 60
 - Hysteresis: User selectable

Environmental

- Operating temperature: -10 to +70°C (+14 to +158 °F)
- Storage temperature: -30 to +80°C (-22 to +176 °F)
- Relative humidity: 0 to 95% not condensing

Standards & Approvals

- Manufactured under ISO 9001
- Manufactured under ISO 14001
- CE
- RoHS Compliant
- EAC
- FDA on request for paddlewheel in C-PVC/EPDM, PVDF/EPDM, SS316L/EPDM.

WIRING CONNECTIONS

Rear Terminal View

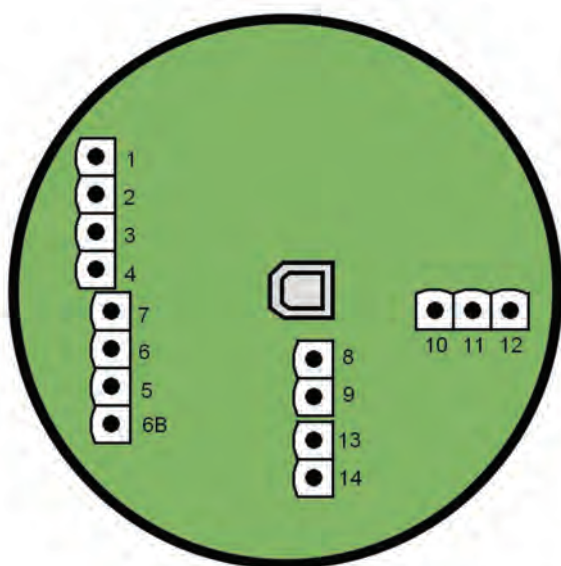

1	+VDC	Power Supply
2	+LOOP	
3	-LOOP	
4	-VDC	
7	V+	Flow Sensor
6	FREQ IN	
5	GND	
6B	DIR	
8	NO	SSR1
9	COM	
10	NC	RELAY
11	COM	
12	NO	
13	NO	SSR2
14	COM	

ORDERING DATA

M9.02 Flow Monitor and Transmitter						
Part No.	Description /Name	Power supply	Wire power Technology	Sensor Input	Output	Weight (gr.)
M9.02.P1	Panel mount Flow monitor	12 - 24 VDC	3/4 wire	Flow (Frequency)	1*(4-20mA), 2*(S.S.R.), 1*(mech. relay)	500
M9.02.W1	Wall mount Flow monitor	12 - 24 VDC	3/4 wire	Flow (Frequency)	1*(4-20mA), 2*(S.S.R.), 1*(mech. relay)	550
M9.02.W2	Wall mount Flow monitor	110 - 230 VAC	3/4 wire	Flow (Frequency)	1*(4-20mA), 2*(S.S.R.), 1*(mech. relay)	650

M9.02 Flow Monitor and Transmitter Field mount								
Part No.	Description /Name	Power supply	Wire power Technology	Sensor Input	Output	Lenght	Main Wetted Materials	Weight (gr.)
M9.02.01	Field mount Flow monitor	12 - 24 VDC	3/4 wire	Flow (Frequency)	1*(4-20mA), 2*(S.S.R.), 1*(mech. relay)	L0	C-PVC/EPDM	550
M9.02.02	Field mount Flow monitor	12 - 24 VDC	3/4 wire	Flow (Frequency)	1*(4-20mA), 2*(S.S.R.), 1*(mech. relay)	L0	C-PVC/FPM	550
M9.02.03	Field mount Flow monitor	12 - 24 VDC	3/4 wire	Flow (Frequency)	1*(4-20mA), 2*(S.S.R.), 1*(mech. relay)	L1	C-PVC/EPDM	550
M9.02.04	Field mount Flow monitor	12 - 24 VDC	3/4 wire	Flow (Frequency)	1*(4-20mA), 2*(S.S.R.), 1*(mech. relay)	L1	C-PVC /FPM	550
M9.02.05	Field mount Flow monitor	12 - 24 VDC	3/4 wire	Flow (Frequency)	1*(4-20mA), 2*(S.S.R.), 1*(mech. relay)	L0	PVDF/EPDM	550
M9.02.06	Field mount Flow monitor	12 - 24 VDC	3/4 wire	Flow (Frequency)	1*(4-20mA), 2*(S.S.R.), 1*(mech. relay)	L0	PVDF/FPM	550
M9.02.07	Field mount Flow monitor	12 - 24 VDC	3/4 wire	Flow (Frequency)	1*(4-20mA), 2*(S.S.R.), 1*(mech. relay)	L1	PVDF/EPDM	550
M9.02.08	Field mount Flow monitor	12 - 24 VDC	3/4 wire	Flow (Frequency)	1*(4-20mA), 2*(S.S.R.), 1*(mech. relay)	L1	PVDF/FPM	550
M9.02.09	Field mount Flow monitor	12 - 24 VDC	3/4 wire	Flow (Frequency)	1*(4-20mA), 2*(S.S.R.), 1*(mech. relay)	L0	SS316L/EPDM	600
M9.02.10	Field mount Flow monitor	12 - 24 VDC	3/4 wire	Flow (Frequency)	1*(4-20mA), 2*(S.S.R.), 1*(mech. relay)	L0	SS316L/FPM	600
M9.02.11	Field mount Flow monitor	12 - 24 VDC	3/4 wire	Flow (Frequency)	1*(4-20mA), 2*(S.S.R.), 1*(mech. relay)	L1	SS316L/EPDM	600
M9.02.12	Field mount Flow monitor	12 - 24 VDC	3/4 wire	Flow (Frequency)	1*(4-20mA), 2*(S.S.R.), 1*(mech. relay)	L1	SS316L/FPM	600

FLS M9.00

2-WIRES FLOW MONITOR & TRANSMITTER



The new FLS M9.00 is a powerful flow monitor and transmitter based on 2-wire technology designed to convert the frequency signal of FLS flow sensors into a flow rate. M9.00 is equipped with a wide 4" display which shows measured values clearly. Moreover the standard backlight improves further the display visibility.

The first procedure will grant a easy set up of main parameters. A flow rate reference can be used for a recalibration or a alignment through a intuitive "in-line calibration". A 2 wires 4-20mA output combined with a solid state relay allow to remote instant flow rate as well as an alarm. M9.00 is equipped with a USB port which allows a easy updating of instrument software by customer.

APPLICATIONS

- Water treatment systems
- Industrial waste water treatment and recovery
- Water distribution
- Filtration systems
- Swimming pools & SPA
- Irrigation & Fertigation
- Leak detection

MAIN FEATURES

- Wide display
- Bright backlight
- Installation flexibility
- Solid State Relays for programmable alarms
- Multilanguage menu
- USB port for software updating



TECHNICAL DATA

General

- Associated flow sensor: FLS hall effect paddlewheel (freq. output), FLS reed ULF
- Materials:
 - Case: ABS
 - Display window: PC
 - Panel & Wall gasket: silicone rubber
 - Keypad: 5-button silicone rubber
- Display
 - transfective technology
 - backlight version: mono colour
 - backlight activation: available without analog output activation
 - Update rate: 1 second
 - Enclosure: IP65 front
 - Flow input Range (frequency): 0.5 to 500 Hz
 - Flow input accuracy: 0,5%

- User selectable as MIN alarm, MAX alarm, Pulse Out, Window alarm, Off
- Optically isolated, 50 mA MAX sink, 24 VAC/VDC MAX pull-up voltage
- Max pulse/min: 300
- Hysteresis: User selectable

Environmental

- Operating temperature: -10 to +70°C (+14 to +158° F)
- Storage temperature: -30 to +80°C (-22 to 176°F)
- Relative humidity: 0 to 95% not condensing

Standards & Approvals

- Manufactured under ISO 9001
- Manufactured under ISO 14001
- CE
- RoHS Compliant
- EAC
- FDA on request for paddlewheel in C-PVC/EPDM, PVDF/EPDM, SS316L/EPDM.

Electrical

- Supply Voltage: 12 to 24 VDC ± 10% regulated
- Max Power Consumption: <20mA (Backlight OFF); <30mA (Backlight ON)
- Backlight is available with power supply \geq 12 VDC
- FLS hall effect flow Sensor power:
 - 3,8 VDC @ < 20 mA
 - Optically isolated from current loop
 - Short circuit protected
- 1*Current output (Not available with backlight ON):
 - 4...20 mA, isolated, fully adjustable and reversible
 - Max loop impedance: 150Ω @ 12 VDC, 600Ω @ 24 VDC
- Solid-State relay output:

WIRING CONNECTIONS

Rear Terminal View

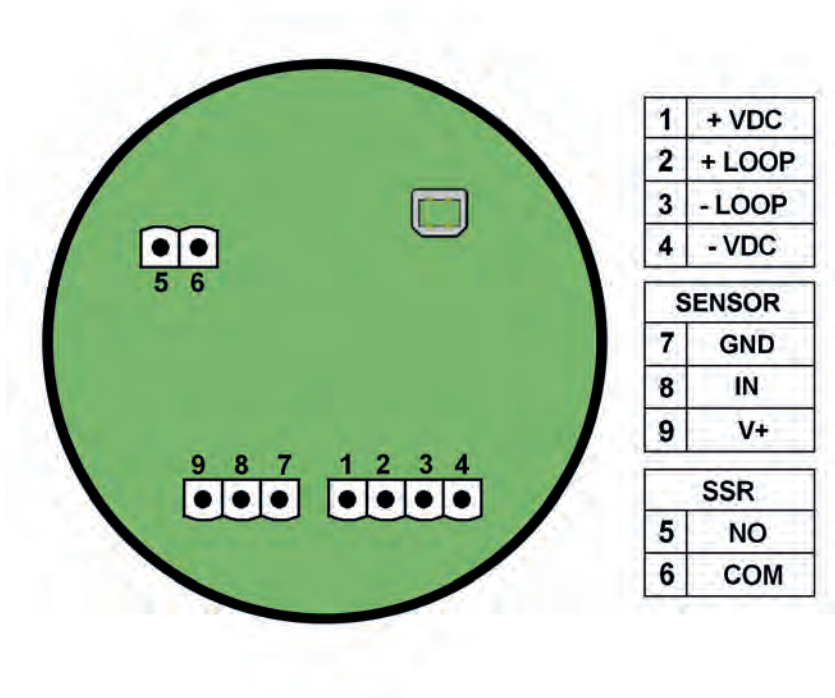

ORDERING DATA

M9.00 2-Wires Flow Monitor and Transmitter						
Part No.	Description /Name	Power supply	Wire power Technology	Sensor Input	Output	Weight (gr.)
M9.00.P1	Panel mount Flow Monitor	12 - 24 VDC	2 wire	Flow (Frequency)	1*(4-20mA), 1*(S.S.R.)	500
M9.00.W1	Wall mount Flow Monitor	12 - 24 VDC	2 wire	Flow (Frequency)	1*(4-20mA), 1*(S.S.R.)	550
M9.00.W2	Wall mount Flow Monitor	110 - 230 VAC	2 wire	Flow (Frequency)	1*(4-20mA), 1*(S.S.R.)	650

M9.00 2-Wires Flow Monitor and Transmitter Field mount								
Part No.	Description / Name	Power supply	Wire power Technology	Sensor Input	Output	Lenght	Main Wetted Materials	Weight (gr.)
M9.00.01	Field mount Flow Monitor	12 - 24 VDC	2 wire	Flow (Frequency)	1*(4-20mA), 1*(S.S.R.)	L0	C-PVCEPDM	550
M9.00.02	Field mount Flow Monitor	12 - 24 VDC	2 wire	Flow (Frequency)	1*(4-20mA), 1*(S.S.R.)	L0	C-PVC/FPM	550
M9.00.03	Field mount Flow Monitor	12 - 24 VDC	2 wire	Flow (Frequency)	1*(4-20mA), 1*(S.S.R.)	L1	C-PVC/EPDM	550
M9.00.04	Field mount Flow Monitor	12 - 24 VDC	2 wire	Flow (Frequency)	1*(4-20mA), 1*(S.S.R.)	L1	C-PVC/FPM	550
M9.00.05	Field mount Flow Monitor	12 - 24 VDC	2 wire	Flow (Frequency)	1*(4-20mA), 1*(S.S.R.)	L0	PVDF/EPDM	550
M9.00.06	Field mount Flow Monitor	12 - 24 VDC	2 wire	Flow (Frequency)	1*(4-20mA), 1*(S.S.R.)	L0	PVDF/FPM	550
M9.00.07	Field mount Flow Monitor	12 - 24 VDC	2 wire	Flow (Frequency)	1*(4-20mA), 1*(S.S.R.)	L1	PVDF/EPDM	550
M9.00.08	Field mount Flow Monitor	12 - 24 VDC	2 wire	Flow (Frequency)	1*(4-20mA), 1*(S.S.R.)	L1	PVDF/FPM	550
M9.00.09	Field mount Flow Monitor	12 - 24 VDC	2 wire	Flow (Frequency)	1*(4-20mA), 1*(S.S.R.)	L0	SS316L/EPDM	600
M9.00.10	Field mount Flow Monitor	12 - 24 VDC	2 wire	Flow (Frequency)	1*(4-20mA), 1*(S.S.R.)	L0	SS316L/FPM	600
M9.00.11	Field mount Flow Monitor	12 - 24 VDC	2 wire	Flow (Frequency)	1*(4-20mA), 1*(S.S.R.)	L1	SS316L/EPDM	600
M9.00.12	Field mount Flow Monitor	12 - 24 VDC	2 wire	Flow (Frequency)	1*(4-20mA), 1*(S.S.R.)	L1	SS316L/FPM	600

FLS M9.20

BATTERY POWERED FLOW MONITOR



The new M9.20 is a smart battery powered flow monitor designed to convert the frequency signal of FLS sensors into a flow rate. M9.20 is equipped by a long life lithium battery which powers the sensor also. A wide 4" display is used to show measured values clearly. A first procedure will grant a easy set up of main parameters. A flow rate reference can be used for a recalibration or a alignment through a intuitive "in-line calibration". A safe icon alerts when it's time to replace battery and instrument stores all main parameters automatically. A customizable string allows to tailor easily the view level. M9.20 is equipped with a USB port which allows an easy update of the software by the end users.

APPLICATIONS

- Remote distribution system
- Mobile monitoring system
- Irrigation & Fertigation
- groundwater remediation
- swimming pool & SPA
- Liquid delivery system

MAIN FEATURES

- Wide display
- long-lasting battery
- installation flexibility
- Multilanguage menu
- No data loss at battery replacement
- USB port for software updating



TECHNICAL DATA

General

- Associated flow sensor: FLS Coil effect with frequency output and FLS Reed effect
- Materials:
 - Case: ABS
 - Display window: PC
 - Panel & Wall gasket: silicone rubber
 - Keypad: 5-button silicone rubber
- Display
 - transfective technology
 - Update rate: 1 second
- Enclosure: IP65 front
- Flow input Range (frequency): 0.5 to 500 Hz
- Flow input accuracy: 0,5%

Electrical

- Supply Voltage: 3.6 volt Lithium Thionylchloride Battery, size C, 8.5 Ahr 3
- Max Power Consumption: <400 μ A
- Battery life: nominal 5 years
- FLS Coil effect flow Sensor power:
 - 3.6 Volts

Environmental

- Operating temperature: -5 to +60°C (+23 to +140°F)
- Storage temperature: -10 to +80°C (+14 to +176 °F)
- Relative humidity: 0 to 95% not condensing

Standards & Approvals

- Manufactured under ISO 9001
- Manufactured under ISO 14001
- CE
- RoHS Compliant
- EAC
- FDA on request for paddlewheel in C-PVC/EPDM, PVDF/EPDM, SS316L/EPDM

WIRING CONNECTIONS

Rear Terminal View

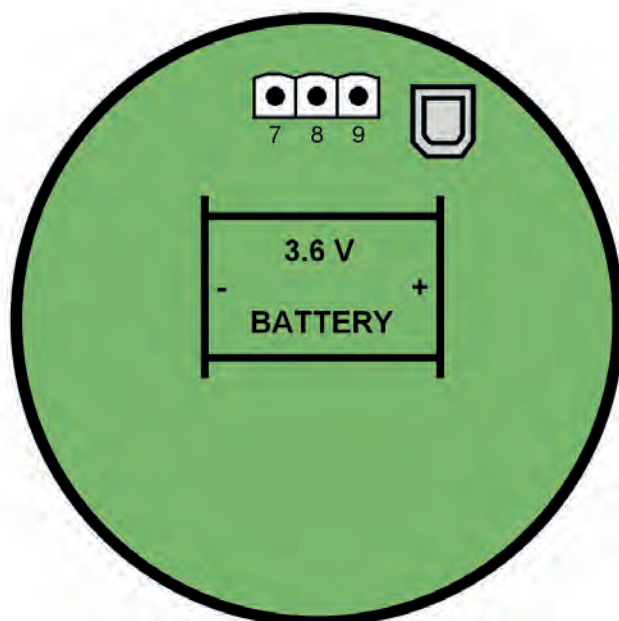

9	V+	Flow Sensor
8	FREQ IN	
7	GND	

ORDERING DATA

M9.20 Battery Powered Flow Monitor						
Part No.	Description /Name	Power supply	Wire power Technology	Sensor Input	Output	Weight (gr.)
M9.20.P1	Panel mount Battery Powered Flow Monitor	Battery Powered	-	Flow (Frequency)	-	500
M9.20.W1	Wall mount Battery Powered Flow Monitor	Battery Powered	-	Flow (Frequency)	-	550

M9.20 Battery Powered Flow Monitor Field Mount								
Part No.	Description / Name	Power supply	Wire power Technology	Sensor Input	Output	Lenght	Main Wetted Materials	Weight (gr.)
M9.20.01	Field mount Battery Powered Flow Monitor	Battery Powered	-	Flow (Frequency)	-	L0	C-PVC/EPDM	550
M9.20.02	Field mount Battery Powered Flow Monitor	Battery Powered	-	Flow (Frequency)	-	L0	C-PVC/FPM	550
M9.20.03	Field mount Battery Powered Flow Monitor	Battery Powered	-	Flow (Frequency)	-	L1	C-PVC/EPDM	550
M9.20.04	Field mount Battery Powered Flow Monitor	Battery Powered	-	Flow (Frequency)	-	L1	C-PVC/FPM	550
M9.20.05	Field mount Battery Powered Flow Monitor	Battery Powered	-	Flow (Frequency)	-	L0	PVDF/EPDM	550
M9.20.06	Field mount Battery Powered Flow Monitor	Battery Powered	-	Flow (Frequency)	-	L0	PVDF/FPM	550
M9.20.07	Field mount Battery Powered Flow Monitor	Battery Powered	-	Flow (Frequency)	-	L1	PVDF/EPDM	550
M9.20.08	Field mount Battery Powered Flow Monitor	Battery Powered	-	Flow (Frequency)	-	L1	PVDF/FPM	550
M9.20.09	Field mount Battery Powered Flow Monitor	Battery Powered	-	Flow (Frequency)	-	L0	SS316L/EPDM	600
M9.20.10	Field mount Battery Powered Flow Monitor	Battery Powered	-	Flow (Frequency)	-	L0	SS316L/FPM	600
M9.20.11	Field mount Battery Powered Flow Monitor	Battery Powered	-	Flow (Frequency)	-	L1	SS316L/EPDM	600
M9.20.12	Field mount Battery Powered Flow Monitor	Battery Powered	-	Flow (Frequency)	-	L1	SS316L/FPM	600

FLS M9.50

BATCH CONTROLLER



The new FLS M9.50 is an electronic device dedicated to accurately batching or blending of different liquids. A 4" wide full graphic display shows measured values clearly and a lot of other useful information. Moreover, thanks to a multicolor display plus a powerful backlight, batching status can be determined easily from afar also. A tutorial software guarantees a mistake-proof and fast set up of every settings. Few advanced options are available to increase precision as well as timing of batch. Possibility of setting different volumes (up to 10 batches) correlated to specific calibration factors maximizes system flexibility guaranteeing highest level of accuracy. A proper package of outputs grants to control and to monitor the batching system remotely. The USB port on the rear part allows the upgrade of software offering a wide range of customization services both standard and on request.

APPLICATIONS

- Batch processes
- Chemical additions
- Filling processes
- Blending applications
- Dosing system
- Bottling processes

MAIN FEATURES

- Wide full graphic display
- Multicolor backlight visualization
- Help on board
- External start, stop and resume
- Intuitive batch volumes setting
- Two stage shutdown control
- Overrun compensation and alarm
- Missing signal alarm
- USB port for software upgrading



TECHNICAL DATA

General

- Associated sensors: FLS hall effect flow sensors with frequency output or FLS F6.60 Flow sensor magmeters
- Materials:
 - case: ABS
 - display window: PC
 - panel & wall gasket: silicone rubber
 - keypad: 5-button silicone rubber
- Display:
 - LC full graphic display
 - backlight version: 3-colours
 - backlight activation: User adjustable with 5 levels of timing
 - update rate: 1 second
 - enclosure: IP65 front
 - Flow input range (frequency): 0÷1500Hz
 - Flow input accuracy (frequency): 0,5%

- Expected mechanical life (min. operations): 10⁷
- Expected electrical life (min. operations): 10⁵ N.O./N.C.switching capacity
- 5A/240VAC
- Max pulse/min: 60
- Hysteresis: User selectable
- User selectable as:
 - OUT1 - Option: Two-stage shutdown, overrun or missing signal alarm
 - OUT2 - Batch: Batch in progress indication

Electrical

- Supply Voltage: 12 to 24 VDC ± 10% regulated
- Max Power Consumption: <300mA
- FLS hall effect flow Sensor power:
 - 5 VDC @ < 20 mA
 - Optically isolated from current loop
 - Short circuit protected
- 2*Solid State Relay output:
 - Optically isolated, 50 mA MAX sink, 24 VDC MAX pull-up voltage
 - Max pulse/min: 300
 - Hysteresis: user selectable
 - User selectable as: Two-stage shutdown, overrun or missing signal alarm
- 2*Relay output:
 - Mechanical SPDT contact

Environmental

- Operating temperature: -10 to +70°C (+14 to +158° F)
- Storage temperature: -30 to +80°C (-22 to +176° F)
- Relative humidity: 0 to 95% not condensing

Standards & Approvals

- Manufactured under ISO 9001
- Manufactured under ISO 14001
- CE
- RoHS Compliant
- EAC

WIRING CONNECTIONS

Rear Terminal View

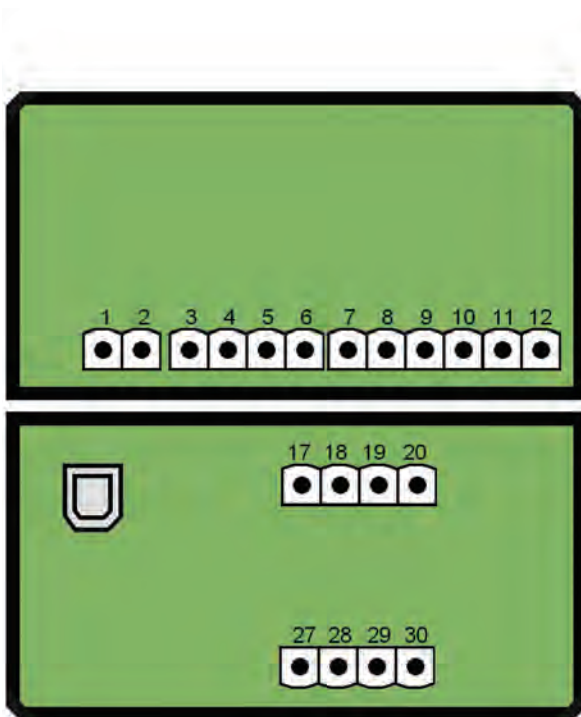

1	-VDC	Power Supply
2	+VDC	
3	NO	SSR2
4	COM	
5	NO	SSR1
6	COM	
7	NO	RELAY1
8	COM	
9	NC	RELAY2
10	NO	
11	COM	
12	NC	
17	GND	Remote control
18	RESUME	
19	START	
20	STOP	
27	+V	Flow Sensor
28	FREQ IN	
29		
30	GND	

ORDERING DATA

M9.50 Batch Controller						
Controller Part No.	Description /Name	Power supply	Wire power Technology	Sensor Input	Output	Weight (gr.)
M9.50.P1	Panel mount Batch controller	12 - 24 VDC	-	Flow (Frequency)	2*(S.S.R.), 2*(mech. relay)	550
M9.50.W1	Wall mount Batch controller	12 - 24 VDC	-	Flow (Frequency)	2*(S.S.R.), 2*(mech. relay)	650
M9.50.W2	Wall mount Batch controller	110 - 230 VAC	-	Flow (Frequency)	2*(S.S.R.), 2*(mech. relay)	750

FLS M9.05

CONDUCTIVITY MONITOR & TRANSMITTER



The new FLS M9.05 is a powerful conductivity monitor and transmitter studied to fit a broad range of applications included ultrapure water process. A 4" wide full graphic display shows measured values clearly together with many other useful information. Moreover, due to the multicolor bright backlight, measurement status can be determined easily also from very long distance. A tutorial software guarantees a mistake-proof and fast set up of every parameter. Measured values can be showed as resistivity or TDS in according with customer needs. A cell constant freely fixable allows to use all types of 2-cell conductivity probe. Two 4-20mA output grants to remote values of conductivity and temperature to external devices. A proper combination of digital outputs allows customized setups for any process to be controlled. The USB port on the rear part allows the upgrade of software offering a wide range of customization services both standard and on request.

APPLICATIONS

- Water treatment and regeneration
- Industrial waste water treatment and recovery
- Softener process
- Filtration systems
- Desalination process
- Demineralized water production
- Reverse osmosis/EDI process
- Cooling water monitoring
- Processing and manufacturing industry
- Chemical production

MAIN FEATURES

- Wide full graphic display
- Multicolor backlight visualization
- Help on board
- UPW temperature compensation
- Cell constant settable freely
- Values in conductivity, resistivity, TDS
- Analog output for temperature remoting
- Mechanical relay for external device control
- Solid State Relays for programmable alarms
- USB port for software upgrading



TECHNICAL DATA

General

- Associated sensors: FLS conductivity sensors and FLS temperature sensors
- Materials:
 - case: ABS
 - display window: PC
 - panel & wall gasket: silicone rubber
 - keypad: 5-button silicone rubber
- Display:
 - LC full graphic display
 - backlight version: 3-colours
 - backlight activation: User adjustable with 5 levels of timing
 - update rate: 1 second
 - enclosure: IP65 front
- Conductivity input range: 0,055÷200000µS/cm (according to the cell constant applied)
- Conductivity measurement accuracy: ± 2.0 % of reading value
- Temperature input range: -50÷150°C (-58÷302°F) (with Pt100-Pt1000)
- Temperature measurement resolution: 0,1°C/°F (Pt1000); 0,5°C/°F (Pt100)

Electrical

- Supply Voltage: 12 to 24 VDC ± 10% regulated
- Max Power Consumption: <300mA
- 2*Current output:
 - 4-20 mA, isolated, fully adjustable and reversible
 - max loop impedance: 800 Ω @ 24 VDC - 250 Ω @ 12 VDC

- 2*Solid State Relay output:
 - user selectable as ON-OFF, Proportional frequency output, Proportional Pulse, Timed Pulse, Off
 - optically isolated, 50 mA MAX sink, 24 VDC MAX pull-up voltage
 - max pulse/min: 300
 - hysteresis: User selectable
- 2*Relay output:
 - user selectable as ON-OFF, Proportional frequency output, Proportional Pulse, Timed Pulse, Off
 - mechanical SPDT contact
 - expected mechanical life (min. operations): 10⁷
 - expected electrical life (min. operations): 10⁵ N.O./N.C.switching capacity 5A/240VAC
 - max pulse/min: 60
 - hysteresis: User selectable

Environmental

- Operating temperature: -10 to +70°C (+14 to +158°F)
- Storage temperature: -30 to +80°C (-22 to +176°F)
- Relative humidity: 0 to 95% not condensing

Standards & Approvals

- Manufactured under ISO 9001
- Manufactured under ISO 14001
- CE
- RoHS Compliant
- EAC

WIRING CONNECTIONS

Rear Terminal View

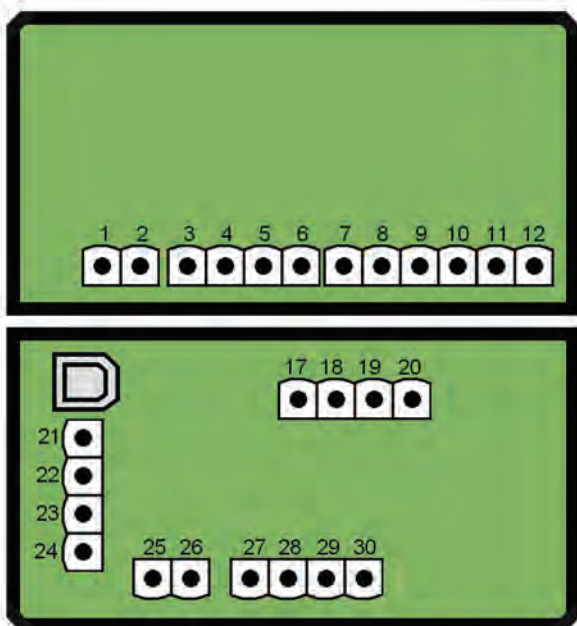

1	-VDC	Power Supply
2	+VDC	
3	NO	SSR1
4	COM	
5	NO	SSR2
6	COM	
7	NO	RELAY1
8	COM	
9	NC	RELAY2
10	NO	
11	COM	
12	NC	
17	+HOLD	Digital Input
18	-HOLD	
19	+REED	
20	-REED	
21	-LOOP2	Analog Output
22	+LOOP2	
23	-LOOP1	
24	+LOOP1	
25	+IN	Conductivity Sensor
26	REF	
27		PT100 - PT1000
28		
29		
30		

ORDERING DATA

M9.05 Conductivity Monitor and Transmitter						
Part No.	Description /Name	Power supply	Wire power Technology	Sensor Input	Output	Weight (gr.)
M9.05.P1	Panel mount Conductivity monitor	12 - 24 VDC	3/4 wire	Conductivity	2*(4-20mA), 2*(S.S.R.), 2*(mech. relay)	550
M9.05.W1	Wall mount Conductivity monitor	12 - 24 VDC	3/4 wire	Conductivity	2*(4-20mA), 2*(S.S.R.), 2*(mech. relay)	650
M9.05.W2	Wall mount Conductivity monitor	110 - 230 VAC	3/4 wire	Conductivity	2*(4-20mA), 2*(S.S.R.), 2*(mech. relay)	750

FLS M9.06

pH/ORP MONITOR & TRANSMITTER



The new FLS M9.06 is a powerful pH/ORP monitor and transmitter designed to satisfy a broad range of applications. A 4" wide full graphic display shows measured values clearly together with many other useful information. Moreover, due to the multicolor bright backlight, measurement status can be determined easily also from very long distance. A tutorial software guarantees a mistake-proof and fast set up of every parameter. A calibration based on automatic buffer recognition plus a in line adjustment allow to achieve a precise and a reliable measurement in every conditions. FLS M9.06 offers a diagnostic of electrode condition with practical tips for maximizing probe performances. The USB port on the rear part allows the upgrade of software offering a wide range of customization services both standard and on request.

APPLICATIONS

- Water treatment and regeneration
- Industrial waste water treatment and recovery
- Scrubber control
- Neutralization systems
- Heavy metals recovery
- Metal surface coating
- Processing and manufacturing industry
- Chemical production
- Swimming pools and SPA

MAIN FEATURES

- Wide full graphic display
- Multicolor backlight visualization
- Help on board
- Automatic recognition of pH buffers
- In line adjustment
- Analog output for temperature remoting
- Mechanical relay for external device control
- Solid State Relays for programmable alarms
- USB port for software upgrading



TECHNICAL DATA

General

- Associated sensors: FLS pH/ORP electrodes and FLS temperature sensors
- Materials:
 - Case: ABS
 - Display window: PC
 - Panel & Wall gasket: silicone rubber
 - Keypad: 5-button silicone rubber
- Display:
 - LC full graphic display
 - Backlight version: 3-colours
 - Backlight activation: User adjustable with 5 levels of timing
 - Update rate: 1 second
 - Enclosure: IP65 front
- pH input range: -2÷16pH (according to the pH electrode applied)
- pH measurement resolution: ± 0.01 pH
- ORP input range: -2000÷ +2000mV (according to the ORP probe applied)
- ORP measurement resolution: ± 1 mV
- Temperature input range: -50÷150°C (-58÷302°F) (with Pt100-Pt1000)
- Temperature measurement resolution: 0,1°C/°F (Pt1000); 0,5°C/°F (Pt100)

Electrical

- Supply Voltage: 12 to 24 VDC ± 10% regulated
- Max Power Consumption: <300mA
- 2*Current output:
 - 4-20 mA, isolated, fully adjustable and reversible
 - Max loop impedance: 800 Ω @ 24 VDC - 250 Ω @ 12 VDC

- 2*Solid State Relay output:
 - User selectable as ON-OFF, Proportional frequency output, Proportional Pulse, Timed Pulse, Off
 - Optically isolated, 50 mA MAX sink, 24 VDC MAX pull-up voltage
 - Max pulse/min: 300
 - Hysteresis: User selectable
- 2*Relay output:
 - User selectable as ON-OFF, Proportional frequency output, Proportional Pulse, Timed Pulse, Off
 - Mechanical SPDT contact
 - Expected mechanical life (min. operations): 10⁷
 - Expected electrical life (min. operations): 10⁵ N.O./N.C.switching capacity 5A/240VAC
 - Max pulse/min: 60
 - Hysteresis: User selectable

Environmental

- Operating temperature: -10 to +70°C (+14 to +158°F)
- Storage temperature: -30 to +80°C (-22 to +176°F)
- Relative humidity: 0 to 95% not condensing

Standards & Approvals

- Manufactured under ISO 9001
- Manufactured under ISO 14001
- CE
- RoHS Compliant
- EAC

WIRING CONNECTIONS

Rear Terminal View

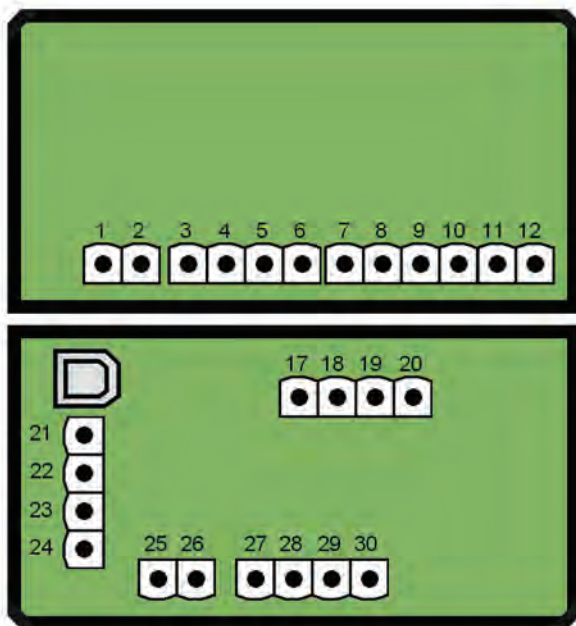

1	-VDC	Power Supply
2	+VDC	
3	NO	SSR1
4	COM	
5	NO	SSR2
6	COM	
7	NO	RELAY1
8	COM	
9	NC	
10	NO	RELAY2
11	COM	
12	NC	
17	+HOLD	Digital Input
18	-HOLD	
19	+REED	
20	-REED	
21	-LOOP2	Analog Output
22	+LOOP2	
23	-LOOP1	
24	+LOOP1	
25	+IN	} pH/ORP Input
26		
27	REF pH	} PT100 - PT1000
28		
29		
30		

ORDERING DATA

M9.06 pH/ORP Monitor and Transmitter						
Part No.	Description /Name	Power supply	Wire power Technology	Sensor Input	Output	Weight (gr.)
M9.06.P1	Panel mount pH/ORP monitor	12 - 24 VDC	3/4 wire	pH/ORP	2*(4-20mA), 2*(S.S.R.), 2*(mech. relay)	550
M9.06.W1	Wall mount pH/ORP monitor	12 - 24 VDC	3/4 wire	pH/ORP	2*(4-20mA), 2*(S.S.R.), 2*(mech. relay)	650
M9.06.W2	Wall mount pH/ORP monitor	110 - 230 VAC	3/4 wire	pH/ORP	2*(4-20mA), 2*(S.S.R.), 2*(mech. relay)	750

FLS M9.03

DUAL-PARAMETER FLOW MONITOR AND TRANSMITTER



The new FLS M9.03 is a powerful dual flow monitor designed to convert the frequency signals of FLS flow sensors into flow rates. M9.03 is equipped with a 4" wide full graphic display which shows measured values clearly and a lot of other useful information. Moreover, due to a multicolor backlight, measurement status can be determined easily from afar also. A tutorial software guarantees a mistake-proof and fast set up of every parameters. Calibrations can be performed just fixing installation features or using a reference value through a new "in-line calibration". Two 4-20mA output are available to remote each flow rate to an external device. A proper combination of digital outputs allows customized setups for any process to be controlled. The USB port on the rear part allows the upgrade of software offering a wide range of customization services both standard and on request.

APPLICATIONS

- Water treatment systems
- Industrial waste water treatment and recovery
- Water distribution
- Filtration systems
- Swimming pools & SPA
- Irrigation & Fertigation
- Leak detection
- Cooling water monitoring
- Processing and manufacturing industry
- Chemical production

MAIN FEATURES

- Wide full graphic display
- Multicolor backlight
- Help on board
- Delta flow rates visualization
- Fast, intuitive and mistake-proof calibration software
- Mechanical relays for external device control
- Solid State Relays for programmable alarms
- Multilanguage menu
- USB port for software upgrading



TECHNICAL DATA

General

- Associated sensors: 2*FLS hall effect flow sensors with frequency output or FLS F6.60 flow magmeters
- Materials:
 - case: ABS
 - display window: PC
 - panel & wall gasket: silicone rubber
 - keypad: 5-button silicone rubber
- Display:
 - LC full graphic display
 - backlight version: 3-colours
 - backlight activation: User adjustable with 5 levels of timing
 - update rate: 1 second
 - enclosure: IP65 front
- Flow input range (frequency): 0÷1500Hz
- Flow input accuracy (frequency): 0,5%

Electrical

- Supply Voltage: 12 to 24 VDC ± 10% regulated
- Max Power Consumption: <300mA
- FLS hall effect flow Sensor power:
 - 5 VDC @ < 20 mA
 - optically isolated from current loop
 - short circuit protected
- 2*Current output:
 - 4-20 mA, isolated, fully adjustable and reversible
 - max loop impedance: 800 Ω @ 24 VDC - 250 Ω @ 12 VDC
- 2*Solid State Relay output:
 - user selectable as MIN alarm, MAX alarm, Pulse Out, Window alarm, Off
 - optically isolated, 50 mA MAX sink, 24 VDC MAX pull-up voltage
 - max pulse/min: 300

- hysteresis: user selectable
- 2*Relay output:
 - user selectable as MIN alarm, MAX alarm, Pulse Out, Window alarm, Off
 - mechanical SPDT contact
 - expected mechanical life (min. operations): 10⁷
 - expected electrical life (min. operations): 10⁵ N.O./N.C.switching capacity 5A/240VAC
 - max pulse/min: 60
 - hysteresis: User selectable

Environmental

- Operating temperature: -10 to +70°C (+14 to +158°F)
- Storage temperature: -30 to +80°C (+14 to +158°F)
- Relative humidity: 0 to 95% not condensing

Standards & Approvals

- Manufactured under ISO 9001
- Manufactured under ISO 14001
- CE
- RoHS Compliant
- EAC

WIRING CONNECTIONS

Rear Terminal View

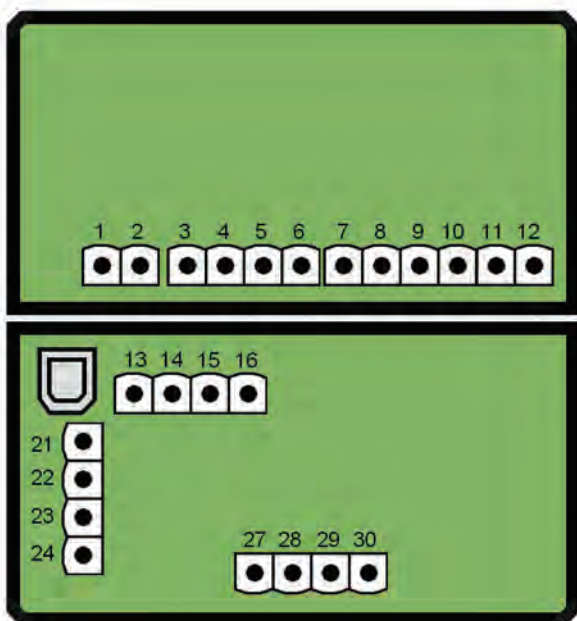

1	-VDC	Power Supply
2	+VDC	
3	NO	SSR1
4	COM	
5	NO	SSR2
6	COM	
7	NO	RELAY1
8	COM	
9	NC	RELAY2
10	NO	
11	COM	
12	NC	
13	+V	Flow Sensor 2
14	FREQ IN	
15	DIR	
16	GND	
21	-LOOP2	Analog Output
22	+LOOP2	
23	-LOOP1	
24	+LOOP1	
27	+V	Flow Sensor 1
28	FREQ IN	
29	DIR	
30	GND	

ORDERING DATA

M9.03 Dual Flow Monitor and Transmitter						
Part No.	Description /Name	Power supply	Wire power Technology	Sensor Input	Output	Weight (gr.)
M9.03.P1	Panel mount Dual Flow Monitor	12 - 24 VDC	3/4 wire	2 * Flow (Frequency)	2*(4-20mA), 2*(S.S.R.), 2*(mech. relay)	550
M9.03.W1	Wall mount Dual Flow Monitor	12 - 24 VDC	3/4 wire	2 * Flow (Frequency)	2*(4-20mA), 2*(S.S.R.), 2*(mech. relay)	650
M9.03.W2	Wall mount Dual Flow Monitor	110 - 230 VAC	3/4 wire	2 * Flow (Frequency)	2*(4-20mA), 2*(S.S.R.), 2*(mech. relay)	750

FLS M9.07

DUAL-PARAMETER CONDUCTIVITY AND FLOW MONITOR & TRANSMITTER



The new FLS M9.07 is a dual monitor and transmitter which combines conductivity and flow measurements. A 4" wide full graphic display shows measured values clearly together with many other useful information. Moreover, due to a multicolor display plus a powerful backlight, measurement status can be determined easily from afar also. A tutorial software guarantees a mistake-proof and fast set up of every parameters. Different type of calibrations can be performed to fit user needs for both measurements. A 4-20mA output dedicated to each measurement grants to remote values to a external device. A proper combination of digital outputs allows customized setups for any process to be controlled. The USB port on the rear part allows the upgrade of software offering a wide range of customization services both standard and on request.

APPLICATIONS

- Water treatment and regeneration
- Industrial waste water treatment and recovery
- Softener process
- Filtration systems
- Desalination process
- Demineralized water production
- Reverse osmosis process
- Cooling water monitoring
- Processing and manufacturing industry
- Chemical production

MAIN FEATURES

- Wide full graphic display
- Multicolor backlight
- Help on board
- Simultaneous measurement of conductivity, temperature and flow
- Fast, intuitive and mistake-proof calibration software
- Mechanical relay for external device control
- Solid State Relays for programmable alarms
- Multilanguage menus
- USB port for software upgrading



TECHNICAL DATA

General

- Associated sensors: FLS conductivity/temperature sensors & FLS hall effect flow sensors with frequency output or FLS F6.60 Flow sensor magmeters
- Materials:
 - case: ABS
 - display window: PC
 - panel & wall gasket: silicone rubber
 - keypad: 5-button silicone rubber
- Display:
 - LC full graphic disply
 - backlight version: 3-colours
 - backlight activation: User adjustable with 5 levels of timing
 - update rate: 1 second
- enclosure: IP65 front
- Conductivity input range: $0,055 \div 200000 \mu\text{S}/\text{cm}$ (according to the cell constant applied)
- Conductivity measurement accuracy: $\pm 2.0 \%$ of reading value
- Temperature input range: $-50 \div 150^\circ\text{C}$ ($-58 \div 302^\circ\text{F}$) (with Pt100-Pt1000)
- Temperature measurement resolution: $0,1^\circ\text{C}/^\circ\text{F}$ (Pt1000); $0,5^\circ\text{C}/^\circ\text{F}$ (Pt100)
- Flow input range (frequency): $0 \div 1500\text{Hz}$
- Flow input accuracy (frequency): $0,5\%$

Electrical

- Supply Voltage: 12 to 24 VDC $\pm 10\%$ regulated
- Max Power Consumption: $<300\text{mA}$
- FLS hall effect flow Sensor power:
 - 5 VDC @ $< 20 \text{mA}$
 - optically isolated from current loop
 - short circuit protected
- 2*Current output:
 - 4-20 mA, isolated, fully adjustable and reversible

- max loop impedance: 800Ω @ 24 VDC - 250Ω @ 12 VDC
- 2*Solid State Relay output:
 - (Flow) user selectable as MIN alarm, MAX alarm, Pulse Out, Window alarm, Off
 - (Conductivity) user selectable as ON-OFF, Proportional frequency output, Timed Pulse, Off
 - optically isolated, 50 mA MAX sink, 24 VDC MAX pull-up voltage
 - max pulse/min: 300
 - hysteresis: user selectable
- 2*Relay output:
 - (Flow) user selectable as MIN alarm, MAX alarm, Pulse Out, Window alarm, Off
 - (Conductivity) user selectable as ON-OFF, Proportional frequency output, Timed Pulse, Off
 - mechanical SPDT contact
 - expected mechanical life (min. operations): 10^7
 - expected electrical life (min. operations): 10^5N.O./N.C. switching capacity 5A/240VAC
 - max pulse/min: 60
 - hysteresis: user selectable

Environmental

- Operating temperature: -10 to $+70^\circ\text{C}$ ($+14$ to $+158^\circ\text{F}$)
- Storage temperature: -30 to $+80^\circ\text{C}$ (-22 to $+176^\circ\text{F}$)
- Relative humidity: 0 to 95% not condensing

Standards & Approvals

- Manufactured under ISO 9001
- Manufactured under ISO 14001
- CE
- RoHS Compliant
- EAC

WIRING CONNECTIONS

Rear Terminal View

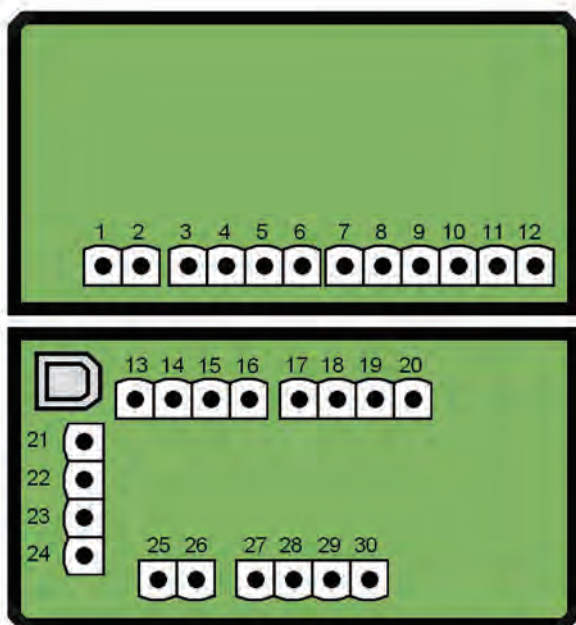

1	-VDC	Power Supply
2	+VDC	
3	NO	SSR1
4	COM	
5	NO	SSR2
6	COM	
7	NO	RELAY1
8	COM	
9	NC	RELAY2
10	NO	
11	COM	
12	NC	
13	+V	Flow Sensor
14	FREQ IN	
15	DIR	
16	GND	
17	+HOLD	Digital Input
18	-HOLD	
19	+REED	
20	-REED	
21	-LOOP2	Analog Output
22	+LOOP2	
23	-LOOP1	
24	+LOOP1	
25	+IN	Conductivity Sensor
26	REF	
27		PT100 - PT1000
28		
29		
30		

ORDERING DATA

M9.07 Conductivity and Flow Monitor and Transmitter						
Part No.	Description /Name	Power supply	Wire power Technology	Sensor Input	Output	Weight (gr.)
M9.07.P1	Panel mount Conductivity & Flow monitor	12 - 24 VDC	3/4 wire	Conductivity, Temperature, Flow (Frequency)	2*(4-20mA), 2*(S.S.R.), 2*(mech. relay)	550
M9.07.W1	Wall mount Conductivity & Flow monitor	12 - 24 VDC	3/4 wire	Conductivity, Temperature, Flow (Frequency)	2*(4-20mA), 2*(S.S.R.), 2*(mech. relay)	650
M9.07.W2	Wall mount Conductivity & Flow monitor	110 - 230 VAC	3/4 wire	Conductivity, Temperature, Flow (Frequency)	2*(4-20mA), 2*(S.S.R.), 2*(mech. relay)	750

FLS M9.08

DUAL-PARAMETER pH/ORP AND FLOW MONITOR AND TRANSMITTER



The new FLS M9.08 is a dual monitor which combines pH/ORP and flow measurements. A wide full graphic display 4" shows measured values clearly and a lot of other useful information. Moreover, due to a multicolor display plus a powerful backlight, measurement status can be determined easily from afar also. A tutorial software guarantees a mistake-proof and fast set up of every settings. Different type of calibrations can be performed to fit user needs for both measurements. A 4-20mA output dedicated to each measurement grants to remote values to a external device. A proper combination of digital outputs allows customized setups for any process to be controlled. The USB port on the rear part allows the upgrade of software offering a wide range of customization services both standard and on request.

APPLICATIONS

- Water treatment and regeneration
- Industrial waste water treatment and recovery
- Scrubber control
- Neutralization systems
- Heavy metals recovery
- Metal surface coating
- Processing and manufacturing industry
- Chemical production
- Swimming pools and SPA

MAIN FEATURES

- Wide graphic display
- Multicolor backlight visualization
- Help on board
- Simultaneous measurement of pH/ORP and flow
- Intuitive calibration procedures
- Mechanical relay for external device control
- Solid State Relays for programmable alarms
- Multilanguages menù
- USB port for software upgrading



TECHNICAL DATA

General

- Associated sensors: FLS pH/ORP sensors & FLS hall effect flow sensors with frequency output or FLS F6.60 family sensors
- Materials:
 - case: ABS
 - display window: PC
 - panel & Wall gasket: silicone rubber
 - keypad: 5-button silicone rubber
- Display:
 - backlight version: 3-colours
 - backlight activation: User adjustable with 5 levels of timing
 - update rate: 1 second
 - enclosure: IP65 front
- pH input range: -2÷16pH (according to the pH electrode applied)
- pH measurement resolution: ± 0.01 pH
- ORP input range: -2000÷ +2000mV (according to the ORP probe applied)
- ORP measurement resolution: ± 1 mV
- Temperature input range: -50÷150°C (-58÷302°F) (with Pt100-Pt1000)
- Temperature measurement resolution: 0,1°C/°F (Pt1000); 0,5°C/°F (Pt100)
- Flow input range (frequency): 0÷1500Hz
- Flow input accuracy (frequency): 0,5%

Electrical

- Supply Voltage: 12 to 24 VDC ± 10% regulated
- Max Power Consumption: <300mA
- FLS hall effect flow Sensor power:
 - 5 VDC @ < 20 mA
 - optically isolated from current loop
 - short circuit protected

- 2*Current output:
 - 4-20 mA, isolated, fully adjustable and reversible
 - max loop impedance: 1000 Ω @ 24 VDC
- 2*Solid State Relay output:
 - (Flow) user selectable as MIN alarm, MAX alarm, Pulse Out, Window alarm, Off
 - (pH/ORP) user selectable as ON-OFF, Proportional frequency output, Timed Pulse, Off
 - optically isolated, 50 mA MAX sink, 24 VDC MAX pull-up voltage
 - max pulse/min: 300
 - hysteresis: User selectable
- 2*Relay output:
 - (Flow) user selectable as MIN alarm, MAX alarm, Pulse Out, Window alarm, Off
 - (pH/ORP) user selectable as ON-OFF, Proportional frequency output, Timed Pulse, Off
 - mechanical SPDT contact
 - expected mechanical life (min. operations): 10⁷
 - expected electrical life (min. operations): 10⁵ N.O./N.C.switching capacity 5A/240VAC
 - max pulse/min: 60
 - hysteresis: user selectable

Environmental

- Operating temperature: -10 to +70°C (+14 to +158°F)
- Storage temperature: -30 to +80°C (-22 to +176°F)
- Relative humidity: 0 to 95% not condensing

Standards & Approvals

- Manufactured under ISO 9001
- Manufactured under ISO 14001
- CE
- RoHS Compliant
- EAC

WIRING CONNECTIONS

Rear Terminal View

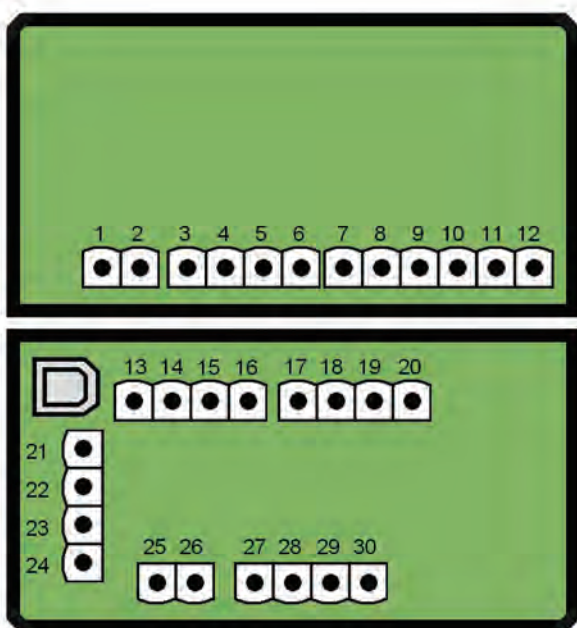

1	-VDC	Power Supply
2	+VDC	
3	NO	SSR1
4	COM	
5	NO	SSR2
6	COM	
7	NO	RELAY1
8	COM	
9	NC	RELAY2
10	NO	
11	COM	
12	NC	
13	+V	Flow Sensor
14	FREQ IN	
15	DIR	
16	GND	
17	+HOLD	Digital Input
18	-HOLD	
19	+REED	
20	-REED	
21	-LOOP2	Analog Output
22	+LOOP2	
23	-LOOP1	
24	+LOOP1	
25	IN+	pH/ORP Input
26		
27	REF	PT100 - PT1000
28		
29		
30		

ORDERING DATA

M9.08 pH/ORP & Flow Monitor and Transmitter						
Part No.	Description /Name	Power supply	Wire power Technology	Sensor Input	Output	Weight (gr.)
M9.08.P1	Panel mount pH/ORP & Flow monitor	12 - 24 VDC	3/4 wire	pH/ORP, Temperature, Flow (Frequency)	2*(4-20mA), 2*(S.S.R.), 2*(mech. relay)	550
M9.08.W1	Wall mount pH/ORP & Flow monitor	12 - 24 VDC	3/4 wire	pH/ORP, Temperature, Flow (Frequency)	2*(4-20mA), 2*(S.S.R.), 2*(mech. relay)	650
M9.08.W2	Wall mount pH/ORP & Flow monitor	110 - 230 VAC	3/4 wire	pH/ORP, Temperature, Flow (Frequency)	2*(4-20mA), 2*(S.S.R.), 2*(mech. relay)	750

FLS M9.10

DUAL-PARAMETER ANALOG MONITOR & TRANSMITTER



The new FLS M9.10 is a powerful monitor and transmitter designed to manage analog and frequency signals (or two analog signals) from every types of device which provide a 4-20mA or a frequency output. M9.10 is equipped with a wide full graphic display 4" which shows measured values clearly and a lot of other useful information. Moreover, due to a multicolor display plus a powerful backlight, measurement status can be determined easily from afar also. A tutorial software guarantees a mistake-proof and fast set up of every parameters. Calibration of 4-20mA input can be performed just fixing 2 points as well as 1 point or using a reference value through a new "in-line calibration". Calibration of frequency input can be performed just fixing installation features or using a reference value through a new "in-line calibration". Two independent 4-20mA outputs are available to remote measures to external devices. A proper combination of digital outputs (2*SSR and 2*relays) allows customized setups for any process to be controlled. The USB port on the rear part allows the upgrade of software offering a wide range of customization services both standard and on request.

APPLICATIONS

- Industrial waste water treatment
- Civil waste water treatment
- Water treatment processes
- Processing and Manufacturing industry
- Chemical processing
- Industrial environment with electromagnetic interferences

MAIN FEATURES

- Wide graphic display
- Multicolor backlight
- Help on board
- Simultaneous visualization of two parameters
- Free setting of engineering unit
- Intuitive calibration procedure
- In line adjustment
- Able to handle active and passive analog signal
- USB port for software upgrading

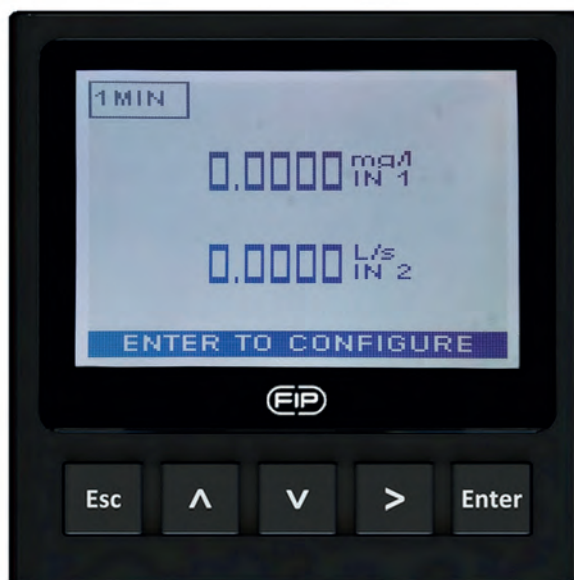

TECHNICAL DATA

General

- Associated sensors: FLS hall effect flow sensors with frequency output, FLS F6.60 Flow sensor magmeters and all devices which generate a passive or active 4-20mA signal.
- Materials:
 - case: ABS
 - display window: PC
 - panel & wall gasket: silicone rubber
 - keypad: 5-button silicone rubber
- Display:
 - LC full graphic display
 - backlight version: 3-colours
 - backlight activation: User adjustable with 5 levels of timing
 - update rate: 1 second
 - enclosure: IP65 front
- Frequency input range (frequency): 0÷1000Hz
- Frequency accuracy (frequency): 0,5%
- Analog input range (frequency): 3,8÷21,0mA
- Analog input accuracy (frequency): 0,01mA

Electrical

- Supply Voltage: 12 to 24 VDC ± 10% regulated
- Max Power Consumption: <300mA
- FLS hall effect flow Sensor power:
 - 5 VDC @ < 20 mA
 - Optically isolated from current loop
 - Short circuit protected
- 2*Current input power:
 - 18VDC @ ≤ 20mA
- 2*Current output:
 - 4-20 mA, isolated, fully adjustable and reversible

- Max loop impedance: 800 Ω @ 24 VDC - 250 Ω @ 12 VDC
- 2*Solid State Relay output:
 - User selectable as MIN alarm, MAX alarm, Pulse Out (only for frequency input), Window alarm, Off
 - Optically isolated, 50 mA MAX sink, 24 VDC MAX pull-up voltage
 - Max pulse/min: 300
 - Hysteresis: User selectable
- 2*Relay output:
 - User selectable as MIN alarm, MAX alarm, Pulse Out (only for frequency input), Window alarm, Off
 - Mechanical SPDT contact
 - Expected mechanical life (min. operations): 10⁷
 - Expected electrical life (min. operations): 10⁵ N.O./N.C. switching capacity 5A/240VAC
 - Max pulse/min: 60
 - Hysteresis: User selectable

Environmental

- Operating temperature: -10 to +70°C (+14 to +158°F)
- Storage temperature: -30 to +80°C (-22 to +176°F)
- Relative humidity: 0 to 95% not condensing

Standards & Approvals

- Manufactured under ISO 9001
- Manufactured under ISO 14001
- CE
- RoHS Compliant
- EAC

WIRING CONNECTIONS

Rear Terminal View

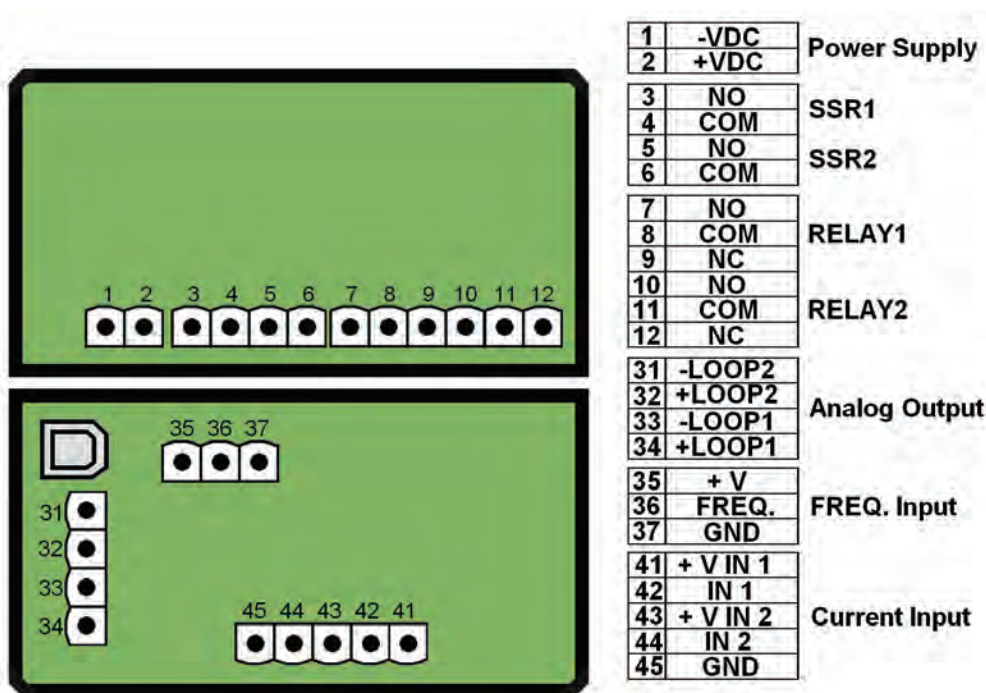

ORDERING DATA

M9.10 Dual Analog Monitor and Transmitter						
Part No.	Description /Name	Power supply	Wire power Technology	Sensor Input	Output	Weight (gr.)
M9.10.P1	Panel mount Dual Analog monitor	12 - 24 VDC	3/4 wire	2 * 4-20mA	2*(4-20mA), 2*(S.S.R.), 2*(mech. relay)	550
M9.10.W1	Wall mount Dual Analog monitor	12 - 24 VDC	3/4 wire	2 * 4-20mA	2*(4-20mA), 2*(S.S.R.), 2*(mech. relay)	650
M9.10.W2	Wall mount Dual Analog monitor	110 - 230 VAC	3/4 wire	2 * 4-20mA	2*(4-20mA), 2*(S.S.R.), 2*(mech. relay)	750



INSERTION PADDLEWHEEL
AND ELECTROMAGNETIC
FLOW SENSORS
**INSTALLATION VERSATILITY
COMBINED TO APPLICATION
FLEXIBILITY**

FLS F3.00

PADDLEWHEEL FLOW SENSOR



The simple and reliable paddlewheel flow sensor type F3.00 is designed for use with every kind of solid-free liquids. The sensor can measure flow from 0.15 m/s (0.5 ft/s) producing a frequency output signal highly repeatable. A rugged construction and a proven technology guarantee exceptional performances with little or no maintenance required.

A dedicated electronic, with a push-pull output, is available for a safe connection to any kind of PLC/Instrument digital input.

A specially designed family of fittings ensures an easy and quick installation into all pipe materials in sizes from DN15 to DN600 (0.5" to 24").

APPLICATIONS

- Water treatment and regeneration
- Industrial wastewater treatment and recovery
- Textile finishing
- Water distribution
- Processing and manufacturing industry
- Filtration systems
- Chemical production
- Liquid delivery systems
- Cooling water monitoring
- Heat Exchangers
- Swimming pools
- Pump protection

MAIN FEATURES

- C-PVC, PVDF or Stainless Steel sensor body
- Two sensor lengths to cover from DN15 up to DN600
- Easy insertion system
- IP65 or IP68 protection class
- Measurement range over 50:1
- High chemical resistance
- Version for battery powered system
- Push-Pull output for universal electrical connection

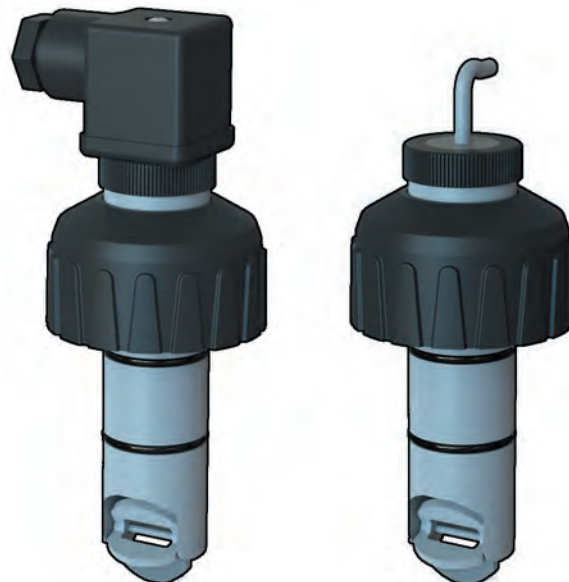

TECHNICAL DATA

General

- Pipe Size Range: DN15 to DN600 (0.5" to 24")
Please refer to Installation Fittings section for more details
- Flow Rate Range: 0.15 to 8 m/s (0.5 to 25 ft./s)
- Linearity: $\pm 0.75\%$ of full scale
- Repeatability: $\pm 0.5\%$ of full scale
- Minimum Reynolds Number Required: 4500
- Enclosure: IP68 or IP65
- Wetted Materials:
 - sensor Body: C-PVC, PVDF or 316L SS
 - o-rings: EPDM or FPM
 - rotor: ECTFE (Halar®)
 - shaft: Ceramic (Al_2O_3)/316L SS (for metal sensors)
 - bearings: Ceramic (Al_2O_3), none (for metal sensor)

Specific for F3.00.H

- Supply voltage: 5 to 24 VDC $\pm 10\%$ regulated
- Supply current: $< 30\text{ mA}$ @ 24 VDC
- Output signal:
 - square wave
 - frequency: 45 Hz per m/s nominal (13.7 Hz per ft/s nominal)
 - type: transistor NPN open collector
 - output current: 10 mA max
- Cable length: 8 m (26.4 ft) standard, 300 m (990 ft) maximum

Specific for F3.00.C

- Supply voltage: 3 to 5 VDC regulated or 3.6 Volt Lithium battery
- Supply current: $< 10\ \mu\text{A}$ max
- Output signal:

- square wave
- frequency: 45 Hz per m/s nominal (13.7 Hz per ft/s nominal)
- min. input impedance: 100 K Ω
- Cable length: 8 m (26.4 ft) standard, 16 m (52.8 ft) maximum

Specific for F3.00.P

- Supply voltage: 12 to 24 VDC $\pm 10\%$ regulated
- Supply current: $< 30\text{ mA}$ @ 24 VDC
- Output signal:
 - square wave
 - frequency: 45 Hz per m/s nominal (13.7 Hz per ft/s nominal)
 - type: Push-Pull (for connection to NPN and PNP inputs)
 - output current: 20 mA max
- Cable length: 8 m (26.4 ft) standard, 300 m (990 ft) maximum

Standards & Approvals

- Manufactured under ISO 9001
- Manufactured under ISO 14001
- CE
- RoHS Compliant
- EAC
- FDA on request for paddlewheel in C-PVC/EPDM, PVDF/EPDM, SS316L/EPDM.

Maximum Operating Pressure / Temperature (25 years lifetime)

F3.00.H or F3.00.P Sensor

- C-PVC body:
 - 10 bar (145 psi) @ 25°C (77°F)
 - 1,5 bar (22 psi) @ 80°C (176°F)
- PVDF body:
 - 10 bar (145 psi) @ 25°C (77°F)
 - 2,5 bar (36 psi) @ 100°C (212°F)
- SS body:
 - 25 bar (363 psi) @ 120°C (248°F)

F3.00.C Sensor

- C-PVC body:
 - 10 bar (145 psi) @ 25°C (77°F)
 - 1,5 bar (22 psi) @ 80°C (176°F)
- PVDF body:
 - 10 bar (145 psi) @ 25°C (77°F)
 - 2,5 bar (36 psi) @ 100°C (212°F)
- SS body:
 - 25 bar (363 psi) @ 100°C (212°F)

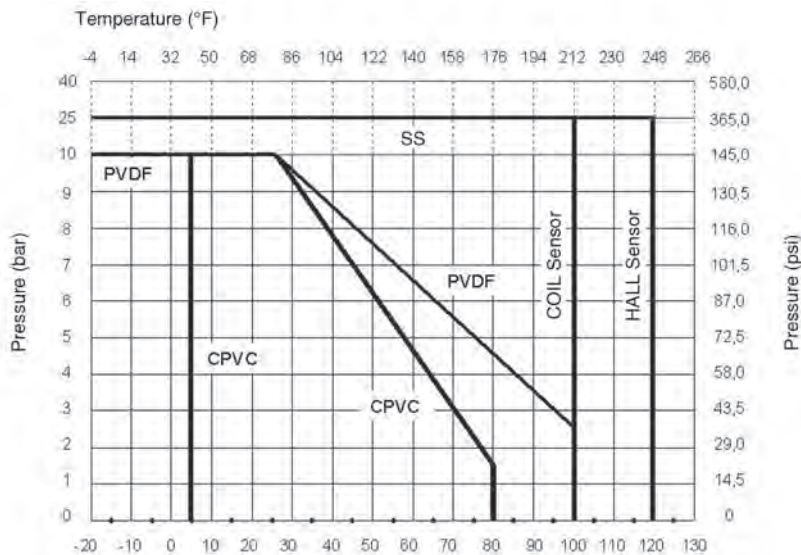

DIMENSIONS

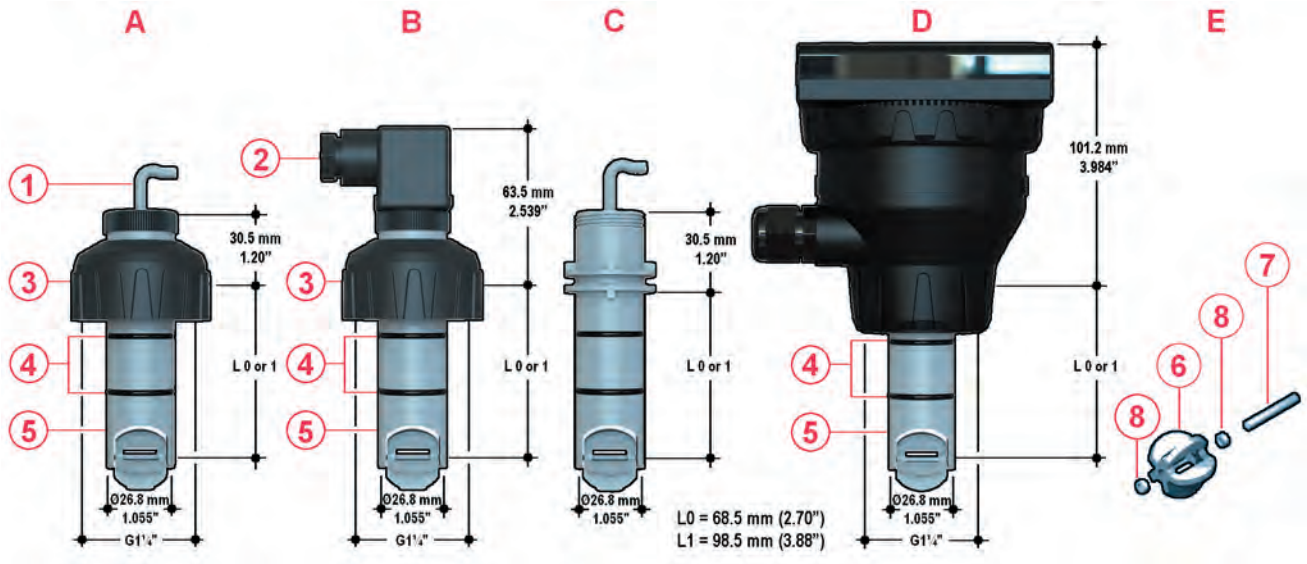

- A F3.00 IP68 Remote Sensor
- B F3.00 IP65 Remote Sensor
- C F3.01 Compact Sensor
- D F3.01 Compact Sensor + Transmitter (sold separately)
- E Paddlewheel system

- 1 Electrical cable: 8 m. (26.4 ft) standard
- 2 4 pole cable plug according to DIN 43650-B/ISO 6952
- 3 U-PVC cap for installation into fittings (SS 316L for metal sensor)
- 4 O-Ring seals available in EPDM or FPM

- 5 C-PVC, PVDF or Stainless Steel sensor body
- 6 ECTFE Halar® (registered trademark of Ausimont-Solvay) Open-cell rotor
- 7 Ceramic shaft (SS 316L for metal sensor)
- 8 Ceramic bearings (none for metal sensor)

WIRING CONNECTIONS

F3.00.H IP68 Sensor wiring connection

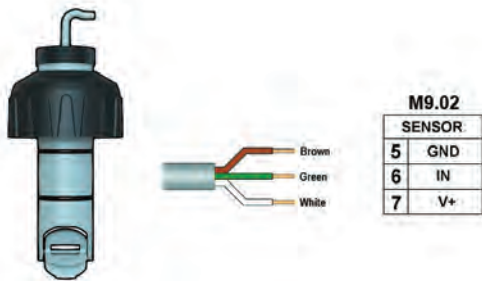

F3.00.H IP65 Sensor wiring connection

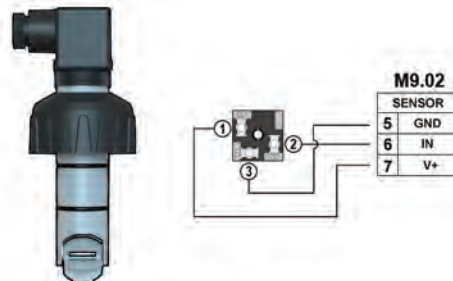

Wiring connections of F3.00.H to the other monitors

	M9.00	M9.50	M9.03	M9.07	M9.08	M9.10
GND	7	30	30	16	16	37
IN	8	28	28	14	14	36
V+	9	27	27	13	13	35

F3.00.C IP68 Sensor wiring connection

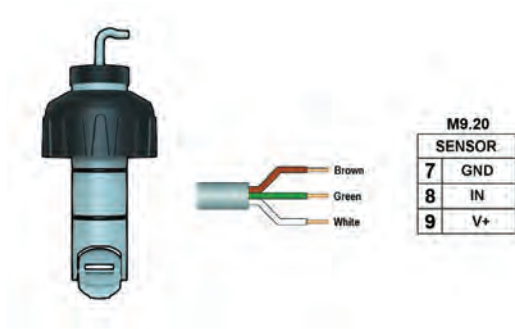

F3.00.C IP65 Sensor wiring connection

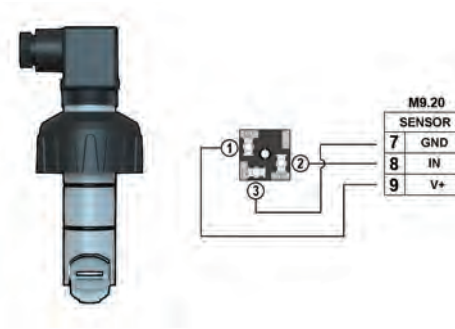

ORDERING DATA

F3.00.H.XX Paddlewheel Flow Sensor (Remote version)							
Part No.	Version	Power supply	Length	Main wetted materials	Enclosure	Flow Rate Range	Weight (gr.)
F3.00.H.01	Hall	5 - 24 VDC	L0	C-PVC/ EPDM	IP68	0.15 to 8 m/s (0.5 to 25 ft./s.)	250
F3.00.H.02	Hall	5 - 24 VDC	L0	C-PVC/FPM	IP68	0.15 to 8 m/s (0.5 to 25 ft./s.)	250
F3.00.H.03	Hall	5 - 24 VDC	L1	C-PVC/ EPDM	IP68	0.15 to 8 m/s (0.5 to 25 ft./s.)	300
F3.00.H.04	Hall	5 - 24 VDC	L1	C-PVC/FPM	IP68	0.15 to 8 m/s (0.5 to 25 ft./s.)	300
F3.00.H.05	Hall	5 - 24 VDC	L0	PVDF/EPDM	IP68	0.15 to 8 m/s (0.5 to 25 ft./s.)	250
F3.00.H.06	Hall	5 - 24 VDC	L0	PVDF/FPM	IP68	0.15 to 8 m/s (0.5 to 25 ft./s.)	250
F3.00.H.07	Hall	5 - 24 VDC	L1	PVDF/EPDM	IP68	0.15 to 8 m/s (0.5 to 25 ft./s.)	300
F3.00.H.08	Hall	5 - 24 VDC	L1	PVDF/FPM	IP68	0.15 to 8 m/s (0.5 to 25 ft./s.)	300
F3.00.H.09	Hall	5 - 24 VDC	L0	316SS/EPDM	IP68	0.15 to 8 m/s (0.5 to 25 ft./s.)	600
F3.00.H.10	Hall	5 - 24 VDC	L0	316SS/FPM	IP68	0.15 to 8 m/s (0.5 to 25 ft./s.)	600
F3.00.H.11	Hall	5 - 24 VDC	L1	316SS/EPDM	IP68	0.15 to 8 m/s (0.5 to 25 ft./s.)	650
F3.00.H.12	Hall	5 - 24 VDC	L1	316SS/FPM	IP68	0.15 to 8 m/s (0.5 to 25 ft./s.)	650
F3.00.H.13	Hall	5 - 24 VDC	L0	C-PVC/EPDM	IP65	0.15 to 8 m/s (0.5 to 25 ft./s.)	250
F3.00.H.14	Hall	5 - 24 VDC	L0	C-PVC/FPM	IP65	0.15 to 8 m/s (0.5 to 25 ft./s.)	250
F3.00.H.15	Hall	5 - 24 VDC	L1	C-PVC/EPDM	IP65	0.15 to 8 m/s (0.5 to 25 ft./s.)	300
F3.00.H.16	Hall	5 - 24 VDC	L1	C-PVC/FPM	IP65	0.15 to 8 m/s (0.5 to 25 ft./s.)	300
F3.00.H.17	Hall	5 - 24 VDC	L0	PVDF/EPDM	IP65	0.15 to 8 m/s (0.5 to 25 ft./s.)	250
F3.00.H.18	Hall	5 - 24 VDC	L0	PVDF/FPM	IP65	0.15 to 8 m/s (0.5 to 25 ft./s.)	250
F3.00.H.19	Hall	5 - 24 VDC	L1	PVDF/EPDM	IP65	0.15 to 8 m/s (0.5 to 25 ft./s.)	300
F3.00.H.20	Hall	5 - 24 VDC	L1	PVDF/FPM	IP65	0.15 to 8 m/s (0.5 to 25 ft./s.)	300
F3.00.H.21	Hall	5 - 24 VDC	L0	316SS/EPDM	IP65	0.15 to 8 m/s (0.5 to 25 ft./s.)	600
F3.00.H.22	Hall	5 - 24 VDC	L0	316SS/FPM	IP65	0.15 to 8 m/s (0.5 to 25 ft./s.)	600
F3.00.H.23	Hall	5 - 24 VDC	L1	316SS/EPDM	IP65	0.15 to 8 m/s (0.5 to 25 ft./s.)	650
F3.00.H.24	Hall	5 - 24 VDC	L1	316SS/FPM	IP65	0.15 to 8 m/s (0.5 to 25 ft./s.)	650

ORDERING DATA

F3.00.C.XX Paddlewheel Flow Sensor (Remote version for Battery powered monitor M9.20)							
Part No.	Version	Power supply	Length	Main wetted materials	Enclosure	Flow Rate Range	Weight (gr.)
F3.00.C.01	Coil	3 - 5 VDC	L0	C-PVC/EPDM	IP68	0.15 to 8 m/s (0.5 to 25 ft./s.)	250
F3.00.C.02	Coil	3 - 5 VDC	L0	C-PVC/FPM	IP68	0.15 to 8 m/s (0.5 to 25 ft./s.)	250
F3.00.C.03	Coil	3 - 5 VDC	L1	C-PVC/EPDM	IP68	0.15 to 8 m/s (0.5 to 25 ft./s.)	300
F3.00.C.04	Coil	3 - 5 VDC	L1	C-PVC/FPM	IP68	0.15 to 8 m/s (0.5 to 25 ft./s.)	300
F3.00.C.05	Coil	3 - 5 VDC	L0	PVDF/EPDM	IP68	0.15 to 8 m/s (0.5 to 25 ft./s.)	250
F3.00.C.06	Coil	3 - 5 VDC	L0	PVDF/FPM	IP68	0.15 to 8 m/s (0.5 to 25 ft./s.)	250
F3.00.C.07	Coil	3 - 5 VDC	L1	PVDF/EPDM	IP68	0.15 to 8 m/s (0.5 to 25 ft./s.)	300
F3.00.C.08	Coil	3 - 5 VDC	L1	PVDF/FPM	IP68	0.15 to 8 m/s (0.5 to 25 ft./s.)	300
F3.00.C.09	Coil	3 - 5 VDC	L0	316SS/EPDM	IP68	0.15 to 8 m/s (0.5 to 25 ft./s.)	600
F3.00.C.10	Coil	3 - 5 VDC	L0	316SS/FPM	IP68	0.15 to 8 m/s (0.5 to 25 ft./s.)	600
F3.00.C.11	Coil	3 - 5 VDC	L1	316SS/EPDM	IP68	0.15 to 8 m/s (0.5 to 25 ft./s.)	650
F3.00.C.12	Coil	3 - 5 VDC	L1	316SS/FPM	IP68	0.15 to 8 m/s (0.5 to 25 ft./s.)	650
F3.00.C.13	Coil	3 - 5 VDC	L0	C-PVC/EPDM	IP65	0.15 to 8 m/s (0.5 to 25 ft./s.)	250
F3.00.C.14	Coil	3 - 5 VDC	L0	C-PVC/FPM	IP65	0.15 to 8 m/s (0.5 to 25 ft./s.)	250
F3.00.C.15	Coil	3 - 5 VDC	L1	C-PVC/EPDM	IP65	0.15 to 8 m/s (0.5 to 25 ft./s.)	300
F3.00.C.16	Coil	3 - 5 VDC	L1	C-PVC/FPM	IP65	0.15 to 8 m/s (0.5 to 25 ft./s.)	300
F3.00.C.17	Coil	3 - 5 VDC	L0	PVDF/EPDM	IP65	0.15 to 8 m/s (0.5 to 25 ft./s.)	250
F3.00.C.18	Coil	3 - 5 VDC	L0	PVDF/FPM	IP65	0.15 to 8 m/s (0.5 to 25 ft./s.)	250
F3.00.C.19	Coil	3 - 5 VDC	L1	PVDF/EPDM	IP65	0.15 to 8 m/s (0.5 to 25 ft./s.)	300
F3.00.C.20	Coil	3 - 5 VDC	L1	PVDF/FPM	IP65	0.15 to 8 m/s (0.5 to 25 ft./s.)	300
F3.00.C.21	Coil	3 - 5 VDC	L0	316SS/EPDM	IP65	0.15 to 8 m/s (0.5 to 25 ft./s.)	600
F3.00.C.22	Coil	3 - 5 VDC	L0	316SS/FPM	IP65	0.15 to 8 m/s (0.5 to 25 ft./s.)	600
F3.00.C.23	Coil	3 - 5 VDC	L1	316SS/EPDM	IP65	0.15 to 8 m/s (0.5 to 25 ft./s.)	650
F3.00.C.24	Coil	3 - 5 VDC	L1	316SS/FPM	IP65	0.15 to 8 m/s (0.5 to 25 ft./s.)	650

ORDERING DATA

F3.00.P.XX Paddlewheel Flow Sensor (for direct connection to PLC)							
Part No.	Version	Power supply	Length	Main wetted materials	Enclosure	Flow Rate Range	Weight (gr.)
F3.00.P.01	Push-Pull	12 - 24 VDC	L0	C-PVC/EPDM	IP68	0.15 to 8 m/s (0.5 to 25 ft./s.)	250
F3.00.P.02	Push-Pull	12 - 24 VDC	L0	C-PVC/FPM	IP68	0.15 to 8 m/s (0.5 to 25 ft./s.)	250
F3.00.P.03	Push-Pull	12 - 24 VDC	L1	C-PVC/EPDM	IP68	0.15 to 8 m/s (0.5 to 25 ft./s.)	300
F3.00.P.04	Push-Pull	12 - 24 VDC	L1	C-PVC/FPM	IP68	0.15 to 8 m/s (0.5 to 25 ft./s.)	300
F3.00.P.05	Push-Pull	12 - 24 VDC	L0	PVDF/EPDM	IP68	0.15 to 8 m/s (0.5 to 25 ft./s.)	250
F3.00.P.06	Push-Pull	12 - 24 VDC	L0	PVDF/FPM	IP68	0.15 to 8 m/s (0.5 to 25 ft./s.)	250
F3.00.P.07	Push-Pull	12 - 24 VDC	L1	PVDF/EPDM	IP68	0.15 to 8 m/s (0.5 to 25 ft./s.)	300
F3.00.P.08	Push-Pull	12 - 24 VDC	L1	PVDF/FPM	IP68	0.15 to 8 m/s (0.5 to 25 ft./s.)	300
F3.00.P.09	Push-Pull	12 - 24 VDC	L0	316SS/EPDM	IP68	0.15 to 8 m/s (0.5 to 25 ft./s.)	600
F3.00.P.10	Push-Pull	12 - 24 VDC	L0	316SS/FPM	IP68	0.15 to 8 m/s (0.5 to 25 ft./s.)	600
F3.00.P.11	Push-Pull	12 - 24 VDC	L1	316SS/EPDM	IP68	0.15 to 8 m/s (0.5 to 25 ft./s.)	650
F3.00.P.12	Push-Pull	12 - 24 VDC	L1	316SS/FPM	IP68	0.15 to 8 m/s (0.5 to 25 ft./s.)	650
F3.00.P.13	Push-Pull	12 - 24 VDC	L0	C-PVC/EPDM	IP65	0.15 to 8 m/s (0.5 to 25 ft./s.)	250
F3.00.P.14	Push-Pull	12 - 24 VDC	L0	C-PVC/FPM	IP65	0.15 to 8 m/s (0.5 to 25 ft./s.)	250
F3.00.P.15	Push-Pull	12 - 24 VDC	L1	C-PVC/EPDM	IP65	0.15 to 8 m/s (0.5 to 25 ft./s.)	300
F3.00.P.16	Push-Pull	12 - 24 VDC	L1	C-PVC/FPM	IP65	0.15 to 8 m/s (0.5 to 25 ft./s.)	300
F3.00.P.17	Push-Pull	12 - 24 VDC	L0	PVDF/EPDM	IP65	0.15 to 8 m/s (0.5 to 25 ft./s.)	250
F3.00.P.18	Push-Pull	12 - 24 VDC	L0	PVDF/FPM	IP65	0.15 to 8 m/s (0.5 to 25 ft./s.)	250
F3.00.P.19	Push-Pull	12 - 24 VDC	L1	PVDF/EPDM	IP65	0.15 to 8 m/s (0.5 to 25 ft./s.)	300
F3.00.P.20	Push-Pull	12 - 24 VDC	L1	PVDF/FPM	IP65	0.15 to 8 m/s (0.5 to 25 ft./s.)	300
F3.00.P.21	Push-Pull	12 - 24 VDC	L0	316SS/EPDM	IP65	0.15 to 8 m/s (0.5 to 25 ft./s.)	600
F3.00.P.22	Push-Pull	12 - 24 VDC	L0	316SS/FPM	IP65	0.15 to 8 m/s (0.5 to 25 ft./s.)	600
F3.00.P.23	Push-Pull	12 - 24 VDC	L1	316SS/EPDM	IP65	0.15 to 8 m/s (0.5 to 25 ft./s.)	650
F3.00.P.24	Push-Pull	12 - 24 VDC	L1	316SS/FPM	IP65	0.15 to 8 m/s (0.5 to 25 ft./s.)	650

INSERTION FLOW SENSORS

ORDERING DATA

F3.01.X.XX Paddlewheel Flow Sensor (Compact version)							
Part No.	Version	Power supply	Length	Main wetted materials	Enclosure	Flow Rate Range	Weight (gr.)
F3.01.H.01	Hall	5 - 24 VDC	L0	C-PVC/EPDM	IP68	0.15 to 8 m/s (0.5 to 25 ft./s.)	250
F3.01.H.02	Hall	5 - 24 VDC	L0	C-PVC/FPM	IP68	0.15 to 8 m/s (0.5 to 25 ft./s.)	250
F3.01.H.03	Hall	5 - 24 VDC	L1	C-PVC/EPDM	IP68	0.15 to 8 m/s (0.5 to 25 ft./s.)	300
F3.01.H.04	Hall	5 - 24 VDC	L1	C-PVC/FPM	IP68	0.15 to 8 m/s (0.5 to 25 ft./s.)	300
F3.01.H.05	Hall	5 - 24 VDC	L0	PVDF/EPDM	IP68	0.15 to 8 m/s (0.5 to 25 ft./s.)	250
F3.01.H.06	Hall	5 - 24 VDC	L0	PVDF/FPM	IP68	0.15 to 8 m/s (0.5 to 25 ft./s.)	250
F3.01.H.07	Hall	5 - 24 VDC	L1	PVDF/EPDM	IP68	0.15 to 8 m/s (0.5 to 25 ft./s.)	300
F3.01.H.08	Hall	5 - 24 VDC	L1	PVDF/FPM	IP68	0.15 to 8 m/s (0.5 to 25 ft./s.)	300
F3.01.H.09	Hall	5 - 24 VDC	L0	316SS/EPDM	IP68	0.15 to 8 m/s (0.5 to 25 ft./s.)	600
F3.01.H.10	Hall	5 - 24 VDC	L0	316SS/FPM	IP68	0.15 to 8 m/s (0.5 to 25 ft./s.)	600
F3.01.H.11	Hall	5 - 24 VDC	L1	316SS/EPDM	IP68	0.15 to 8 m/s (0.5 to 25 ft./s.)	650
F3.01.H.12	Hall	5 - 24 VDC	L1	316SS/FPM	IP68	0.15 to 8 m/s (0.5 to 25 ft./s.)	650
F3.01.C.01	Coil	3 - 5 VDC	L0	C-PVC/EPDM	IP68	0.15 to 8 m/s (0.5 to 25 ft./s.)	250
F3.01.C.02	Coil	3 - 5 VDC	L0	C-PVC/FPM	IP68	0.15 to 8 m/s (0.5 to 25 ft./s.)	250
F3.01.C.03	Coil	3 - 5 VDC	L1	C-PVC/EPDM	IP68	0.15 to 8 m/s (0.5 to 25 ft./s.)	300
F3.01.C.04	Coil	3 - 5 VDC	L1	C-PVC/FPM	IP68	0.15 to 8 m/s (0.5 to 25 ft./s.)	300
F3.01.C.05	Coil	3 - 5 VDC	L0	PVDF/EPDM	IP68	0.15 to 8 m/s (0.5 to 25 ft./s.)	250
F3.01.C.06	Coil	3 - 5 VDC	L0	PVDF/FPM	IP68	0.15 to 8 m/s (0.5 to 25 ft./s.)	250
F3.01.C.07	Coil	3 - 5 VDC	L1	PVDF/EPDM	IP68	0.15 to 8 m/s (0.5 to 25 ft./s.)	300
F3.01.C.08	Coil	3 - 5 VDC	L1	PVDF/FPM	IP68	0.15 to 8 m/s (0.5 to 25 ft./s.)	300
F3.01.C.09	Coil	3 - 5 VDC	L0	316SS/EPDM	IP68	0.15 to 8 m/s (0.5 to 25 ft./s.)	600
F3.01.C.10	Coil	3 - 5 VDC	L0	316SS/FPM	IP68	0.15 to 8 m/s (0.5 to 25 ft./s.)	600
F3.01.C.11	Coil	3 - 5 VDC	L1	316SS/EPDM	IP68	0.15 to 8 m/s (0.5 to 25 ft./s.)	650
F3.01.C.12	Coil	3 - 5 VDC	L1	316SS/FPM	IP68	0.15 to 8 m/s (0.5 to 25 ft./s.)	650

FLS F3.20

HIGH PRESSURE PADDLEWHEEL FLOW SENSOR



FLS F3.20 is a paddlewheel flow sensor suitable for system at high pressure and at critical temperature. F3.20 is designed for use with every kind of solid-free liquids in compliance with chemical compatibilities of wetted materials. First quality materials used, as SS for body/shaft and Halar® for rotor, grant high mechanical performances and an appreciated reliability. Sensor needs a very limited maintenance and, in those cases, it's easy to perform due to a 4 screws system and to a graphite flat gasket. F3.20 sensor is available for connection to FLS monitors and for PLC connection directly. SS weld on adapter is available for sensor installation on pipe range from 1 ½" to 8" (DN40 to DN200).

APPLICATIONS

- Heat Exchangers
- Reverse osmosis
- Cooling systems
- HVAC systems (heating, ventilation and air conditioning)
- Boiler feedwater

MAIN FEATURES

- Working range up to 110 bar (1600 PSI) and up to 248°F (120 °C)
- Wide operating range (from 0,15 to 8 m/s)
- Just one sensor and one fitting for a wide range of pipe dimensions (from 1 ½" to 8")
- High linearity and repeatability
- Limited maintenance need and easy execution
- Available special version for direct connection to PLC



TECHNICAL DATA

General

- Pipe Size Range: DN40 to DN200 (0.5 to 8 in). Refer to Installation Fittings section for more details
- Flow Rate Range: 0.15 to 8 m/s (0.5 to 25 ft./s)
- Linearity: $\pm 0.75\%$ of full scale
- Repeatability: $\pm 0.5\%$ of full scale
- Pressure: 110 bar (1600 psi)
- Temperature: 120 °C (248 °F)
- Minimum Reynolds Number Required: 4500
- Enclosure: IP68
- Wetted Materials:
 - sensor Body: 316L SS
 - sealing system: graphite flat gasket
 - rotor: ECTFE (Halar®)
 - shaft: 316L SS

Specific for F3.20.H

- Supply voltage: 5 to 24 VDC regulated
- Supply current: < 30 mA @ 24 VDC
- Output signal:
 - square wave
 - frequency: 45 Hz per m/s nominal (13.7 Hz per ft/s nominal)
 - output type: transistor NPN open collector
 - output current: 10 mA max
- Cable length: 8 m (26.4 ft) standard, 300 m (990 ft) maximum

Specific for F3.20.P

- Supply voltage: 12 to 24 VDC regulated
- Supply current: < 30 mA @ 24 VCC
- Output signal:
 - square wave
 - output frequency: 45 Hz per m/s nominal (13.7 Hz per ft/s nominal)
 - output type: Push - Pull (digital input NPN or PNP)
 - output current: IOut max < 20 mA
- Cable length: 8 m (26.4 ft) standard, 300 m (990 ft) maximum

Standards & Approvals

- Manufactured under ISO 9001
- Manufactured under ISO 14001
- CE
- RoHS Compliant
- EAC

DIMENSIONS

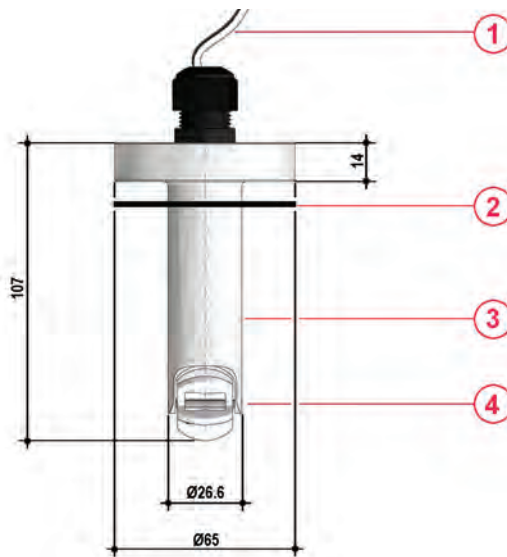

- 1 Electrical cable: 8 m. (26.4 ft) standard
- 2 Graphite flat gasket
- 3 316L SS sensor body
- 4 ECTFE Halar® Open-cell rotor and 316L SS Shaft

WIRING CONNECTIONS

F3.20.H IP68 Sensor wiring connection

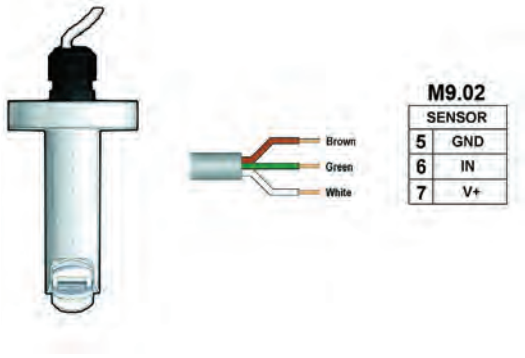

Wiring connections to the other monitors

	M9.00	M9.50	M9.03		M9.07	M9.08	M9.10
GND	7	30	30	16	16	16	37
IN	8	28	28	14	14	14	36
V+	9	27	27	13	13	13	35

ORDERING DATA

F3.20.X.01 High Pressure Paddlewheel Flow Sensor							
Part No.	Version	Power supply	Length	Main Wetted Materials	Enclosure	Flow Rate Range	Weight (gr.)
F3.20.H.01	Hall	5- 24 VDC	107 mm	316L SS	IP 68	0.15 to 8 m/s (0.5 to 25 ft./s)	600
F3.20.P.01	Push-Pull	12- 24 VDC	107 mm	316L SS	IP 68	0.15 to 8 m/s (0.5 to 25 ft./s)	600

FLS F6.30

PADDLEWHEEL FLOW TRANSMITTER



The new FLS F6.30 is a blind transmitter based on paddlewheel. It can be applied for the measurement of every kind of solid-free liquids. The F6.30 can provides different output options using a 4-20 mA and a Solid State Relay. Analog output can be used for long distance transmission and SSR can be set as an alarm or as a volumetric pulse output. F6.30 Paddlewheel Flow Transmitter is provided with an USB interface and a dedicated software (freely downloadable from FLS web site) which allows to easily calibrate instrument and to intuitively set outputs by a PC. The specific design allows an accurate flow measurement over a wide dynamic range in pipe sizes from DN15 (0.5") to DN600 (24").

APPLICATIONS

- Industrial water and wastewater treatment
- Cooling water systems
- Swimming pools
- Flow control and monitoring
- Water treatment
- Water regeneration plant
- Processing and manufacturing industry
- Water distribution

MAIN FEATURES

- High chemical resistance
- Pipe size range: from DN15 (0,5") to DN600 (24")
- Low pressure drop
- Friendly calibration procedure
- 4-20 mA, frequency or volumetric pulse output settable by USB
- SSR settable as alarm by laptop



TECHNICAL DATA

General

- Pipe Size Range: DN15 to DN600 (0.5" to 24")
Please refer to Installation Fittings section for more details
- Flow Rate Range: 0.15 to 8 m/s (0.5 to 25 ft./s)
- Linearity: $\pm 0.75\%$ of full scale
- Repeatability: $\pm 0.5\%$ of full scale
- Minimum Reynolds Number Required: 4500
- Enclosure: IP65
- Wetted Materials:
 - sensor Body: C-PVC, PVDF or 316L SS
 - o-rings: EPDM or FPM
 - rotor: ECTFE (Halar®)
 - shaft: Ceramic (Al_2O_3)/ 316L SS (for metal sensors)
 - bearings: Ceramic (Al_2O_3), none (for metal sensor)

Electrical

- Power Supply:
 - 12 to 24 VDC $\pm 10\%$ regulated (reverse polarity and short circuit protected)
- Max Power Consumption: 150 mA
- protective earth: $< 10 \Omega$
- 1*Current output:
 - 4-20 mA, isolated
 - max. loop impedance: $800 \Omega @ 24 VDC - 250 \Omega @ 12 VDC$
- 1*Solid State Relay output:
 - user selectable as MIN alarm, MAX alarm, Volumetric, Pulse Out, Window alarm, Off
 - optically isolated, 50 mA MAX sink, 24 VDC MAX pull-up voltage
 - max pulse/min: 300
 - hysteresis: User selectable

Environmental

- Storage Temperature: $-30^\circ C$ to $+80^\circ C$ ($-22^\circ F$ to $176^\circ F$)
- Ambient Temperature: $-20^\circ C$ to $+70^\circ C$ ($-4^\circ F$ to $158^\circ F$)
- Relative Humidity: 0 to 95% (non-condensing)

Standards & Approvals

- Manufactured under ISO 9001
- Manufactured under ISO 14001
- CE
- RoHS Compliant
- EAC
- FDA on request for paddlewheel in C-PVC/EPDM, PVDF/EPDM, SS316L/EPDM.

Maximum Operating Pressure / Temperature (25 years lifetime)

F6.30 Transmitter

- C-PVC body:
 - 10 bar (145 psi) @ $25^\circ C$ ($77^\circ F$)
 - 1,5 bar (22 psi) @ $80^\circ C$ ($176^\circ F$)
- PVDF body:
 - 10 bar (145 psi) @ $25^\circ C$ ($77^\circ F$)
 - 2,5 bar (36 psi) @ $100^\circ C$ ($212^\circ F$)
- SS body:
 - 25 bar (363 psi) @ $100^\circ C$ ($212^\circ F$)

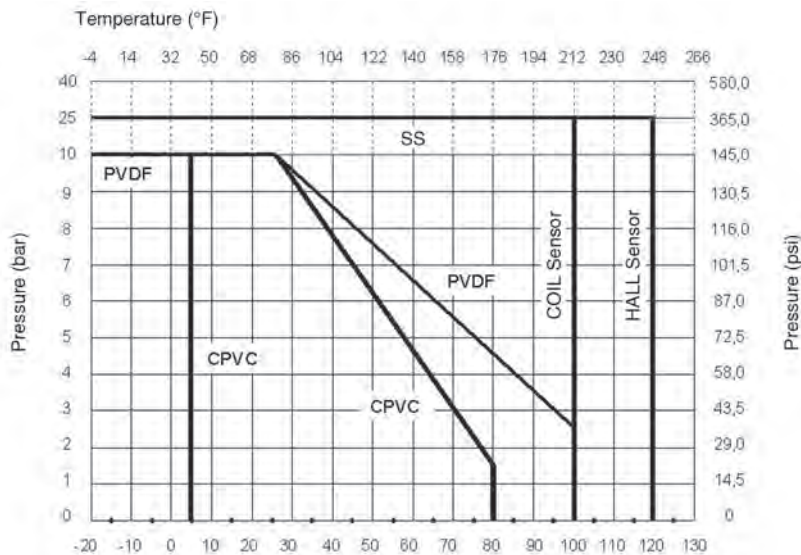

DIMENSIONS

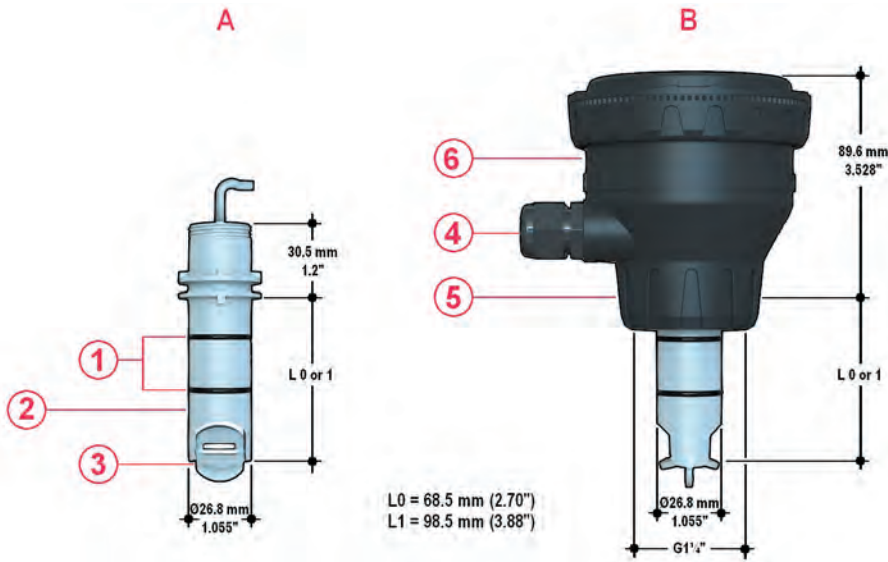

A Sensor body
B F6.30 Paddlewheel Flow Transmitter

- 1 O-Ring (EPDM or FPM)
- 2 Sensor body C-PVC, PVDF, 316L SS
- 3 Halar Rotor, Ceramic shaft & bearings (316L SS shaft for metal sensors)
- 4 Cable Gland

- 5 ABS cap for installation into fittings (SS cap for metal sensors)
- 6 Electronic box

WIRING CONNECTIONS

Rear Terminal View

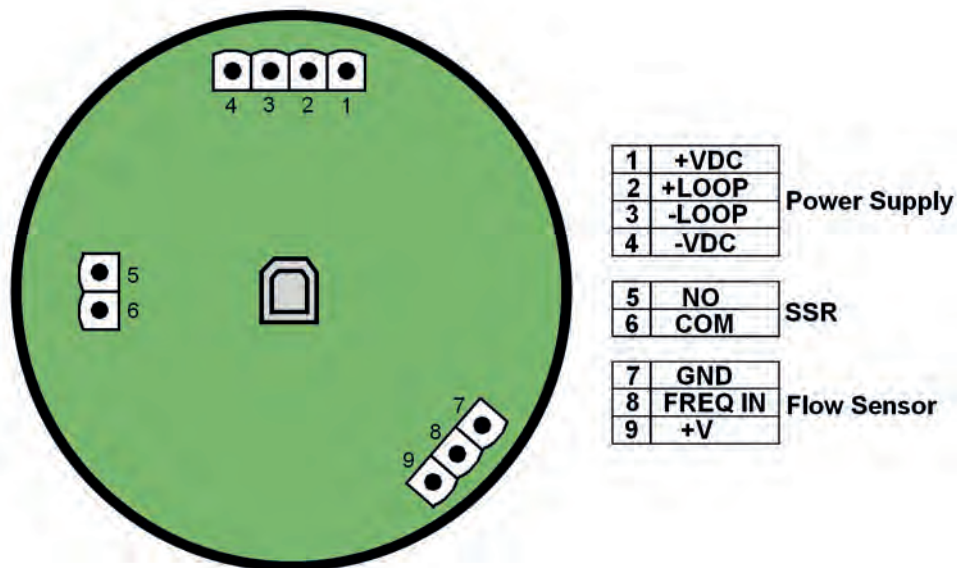

ORDERING DATA

FLS F6.30.XX Paddlewheel Flow Transmitter							
Part No.	Version	Power supply	Length	Main wetted materials	Enclosure	Flow Rate Range	Weight (gr.)
F6.30.01	Hall	12 - 24 VDC	L0	C-PVC/EPDM	IP65	0.15 to 8 m/s (0.5 to 25 ft./s.)	750
F6.30.02	Hall	12 - 24 VDC	L0	C-PVC/FPM	IP65	0.15 to 8 m/s (0.5 to 25 ft./s.)	750
F6.30.03	Hall	12 - 24 VDC	L1	C-PVC/EPDM	IP65	0.15 to 8 m/s (0.5 to 25 ft./s.)	800
F6.30.04	Hall	12 - 24 VDC	L1	C-PVC/FPM	IP65	0.15 to 8 m/s (0.5 to 25 ft./s.)	800
F6.30.05	Hall	12 - 24 VDC	L0	PVDF/EPDM	IP65	0.15 to 8 m/s (0.5 to 25 ft./s.)	750
F6.30.06	Hall	12 - 24 VDC	L0	PVDF/FPM	IP65	0.15 to 8 m/s (0.5 to 25 ft./s.)	750
F6.30.07	Hall	12 - 24 VDC	L1	PVDF/EPDM	IP65	0.15 to 8 m/s (0.5 to 25 ft./s.)	800
F6.30.08	Hall	12 - 24 VDC	L1	PVDF/FPM	IP65	0.15 to 8 m/s (0.5 to 25 ft./s.)	800
F6.30.09	Hall	12 - 24 VDC	L0	316SS/EPDM	IP65	0.15 to 8 m/s (0.5 to 25 ft./s.)	950
F6.30.10	Hall	12 - 24 VDC	L0	316SS/FPM	IP65	0.15 to 8 m/s (0.5 to 25 ft./s.)	950
F6.30.11	Hall	12 - 24 VDC	L1	316SS/EPDM	IP65	0.15 to 8 m/s (0.5 to 25 ft./s.)	1000
F6.30.12	Hall	12 - 24 VDC	L1	316SS/FPM	IP65	0.15 to 8 m/s (0.5 to 25 ft./s.)	1000

INSERTION FLOW SENSORS

FLS F3.10

MINI PADDLEWHEEL FLOW SENSOR



The simple and reliable paddlewheel technology has been moved into this miniflow sensor type FLS F3.10, designed for use with every kind of solid-free liquids. The sensor can measure flow from 0.25 m/s (0.8 ft/s) producing a frequency output signal highly repeatable. A rugged construction and a proven technology guarantee exceptional performances with little or no maintenance required. The very small dimension and a special design make it suitable for installation on FIP standard Tee-fittings from DN15 to DN40 (0.5 to 1.5 in.).

APPLICATIONS

- Water treatment
- Filtration systems
- Pure water production
- Water monitoring
- Fertigation

MAIN FEATURES

- IP68 enclosure
- ABS body with EPDM or FPM seal
- ABS 4-blade paddlewheel (no bearings)
- Mono-directional design
- Installation on standard FIP tees
- PVDF body version on request



TECHNICAL DATA

General

- Pipe Size Range: DN15 to DN40 (0.5 to 1 1/2")
- Please refer to Installation Fittings section for more details
- Flow Rate Range: 0.25 to 4 m/s (0.8 to 12,5 ft./s)
- Linearity: $\pm 1\%$ of full scale
- Repeatability: $\pm 0.5\%$ of full scale. Minimum Reynolds Number Required: 4500
- Enclosure: IP68
- Operating Pressure:
 - max 10 bar (145 psi) @ 20 °C (68°F)
 - max 2 bar (30 psi) @ 70 °C (158°F)
- Operating Temperature: -20°C to 70°C (-4°F to 158°F).
- Wetted Materials:
 - sensor Body: ABS (PVDF on request)
 - o-rings: EPDM or FPM
 - rotor: ABS (PVDF on request)
 - shaft: 316L SS
 - magnets: SmCo₅

Electrical

- Supply current: < 30 mA @ 24 VDC
- Output signal:
 - square wave
 - output frequency: 15 Hz per m/s nominal (4,6 Hz per ft/s nominal)
 - output type: transistor NPN open collector
 - output current: 10 mA max
- Cable length: 2 m (6,5 ft) standard, 300 m (990 ft) maximum

Standards & Approvals

- Manufactured under ISO 9001
- Manufactured under ISO 14001
- CE
- RoHS Compliant
- EAC

DIMENSIONS

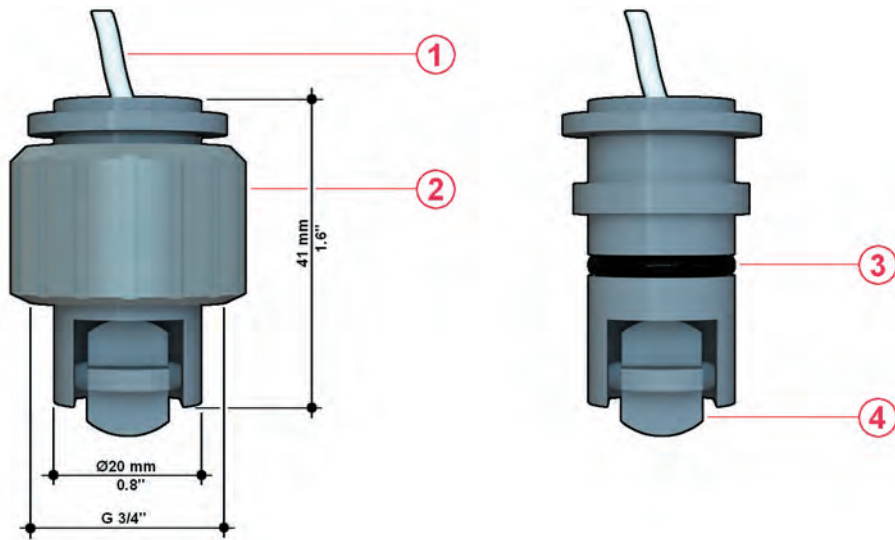

- 1 Electrical cable: 8 m. (26.4 ft) standard
- 2 U-PVC cap for installation into fittings
- 3 O-Ring seals available in EPDM or FPM
- 4 ABS 4-blade rotor and SS shaft

WIRING CONNECTIONS

F3.10 IP68 Sensor wiring connection

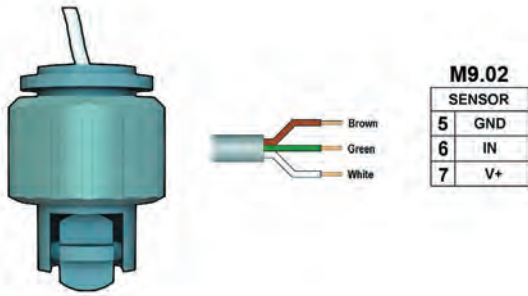

Wiring connections to the other monitors

	M9.00	M9.50	M9.03		M9.07	M9.08	M9.10
GND	7	30	30	16	16	16	37
IN	8	28	28	14	14	14	36
V+	9	27	27	13	13	13	35

ORDERING DATA

F3.10.H.XX Mini Paddlewheel Flow Sensor							
Part No.	Version	Power supply	Length	Main wetted materials	Enclosure	Flow Rate Range	Weight (gr.)
F3.10.H.01	Hall	5 - 24 VDC	41 mm	ABS/EPDM	IP68	0.25 to 4 m/s (0.8 to 12,5 ft./s)	100
F3.10.H.02	Hall	5 - 24 VDC	41 mm	ABS/FPM	IP68	0.25 to 4 m/s (0.8 to 12,5 ft./s)	100

FLS F3.05

PADDLEWHEEL FLOW SWITCH



The simple insertion paddlewheel flow switch type F3.05 is designed to protect a pump from running dry or pumping against a closed valve. It is equipped with a mechanical SPST contact activated when the flow velocity drops below the factory preset value of 0.15 m/s (0.5 ft/s). The F3.05 features a LED which shows the flow status locally.

A specially designed family of fitting ensures an easy and quick installation into all pipe materials in sizes from DN15 to DN600 (0.5" to 24").

APPLICATIONS

- Pump protection
- Filtration systems
- Cooling water systems

MAIN FEATURES

- C-PVC, PVDF, Stainless Steel body
- Easy insertion system
- High chemical resistance
- No-Flow alarm relay output
- Highly visible Local Bicolour Status Indicator
- Maintenance free
- Very low pressure drop

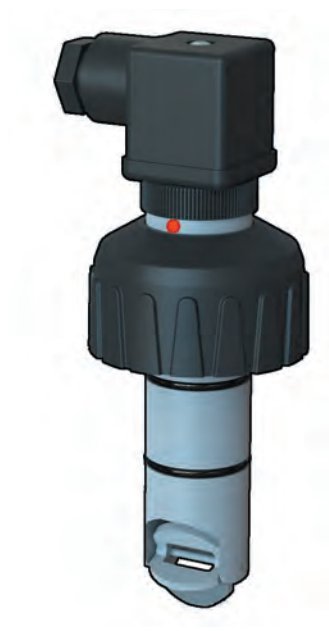

TECHNICAL DATA

General

- Pipe Size Range: DN15 to DN600 (0.5 to 24 in.)
Please refer to Installation Fittings section for more details
- Supply voltage: 12 to 24 VDC \pm 10% regulated
- Supply current: < 50 mA
- Relay Output: mechanical SPDT contact, 1A @ 24 VDC, 0.1A @ 230 VAC
- Local Status Indicator:
 - GREEN Led = Flow
 - RED Led = No Flow
- No-Flow Rate Point: 0.15 m/s (0.5 ft./s)
- Enclosure: IP65
- Wetted Materials:
 - sensor Body: C-PVC or PVDF or 316L SS
 - o-rings: EPDM or FPM
 - rotor: ECTFE (Halar®)
 - shaft: Ceramic (Al_2O_3), 316L SS (for metal sensors)
 - bearings: Ceramic (Al_2O_3), none (for metal sensors)

Standards & Approvals

- Manufactured under ISO 9001
- Manufactured under ISO 14001
- CE
- RoHS Compliant
- EAC
- FDA on request for paddlewheel in C-PVC/EPDM, PVDF/EPDM, SS316L/EPDM.

Maximum Operating Pressure / Temperature (25 years lifetime)

F3.05 Sensor

- C-PVC body:
 - 10 bar (145 psi) @ 25°C (77°F)
 - 1,5 bar (22 psi) @ 80° C (176°F)
- PVDF body:
 - 10 bar (145 psi) @ 25°C (77°F)
 - 2,5 bar (36 psi) @ 100°C (212°F)
- SS body:
 - 25 bar (363 psi) @ 120°C (248°F)

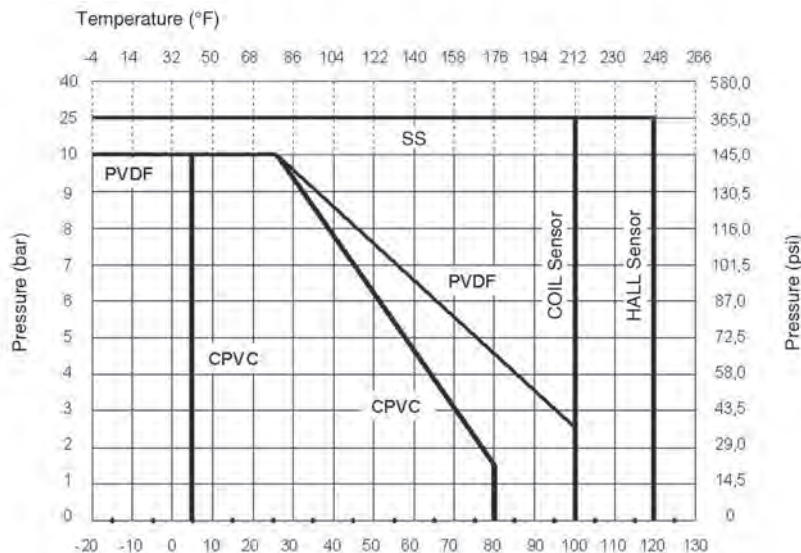

DIMENSIONS

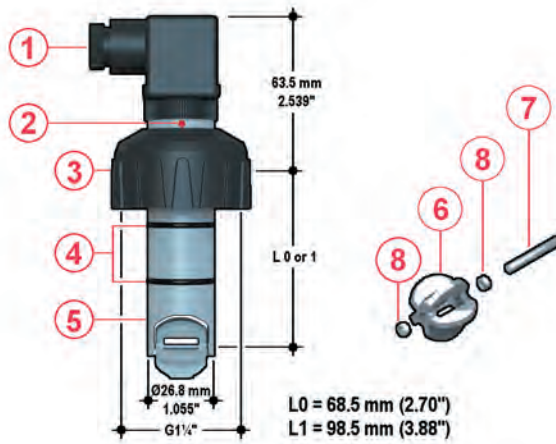

- 1 4 pole cable plug according to DIN 43650-B/ISO 6952
- 2 Local Bicolour Status LED
- 3 U-PVC cap for installation into fittings
- 4 O-Ring seals available in EPDM or FPM

- 5 C-PVC, PVDF or Stainless Steel sensor body
- 6 ECTFE (Halar®) Open-cell rotor
- 7 Ceramic shaft, 316L SS (for metal sensors)
- 8 Ceramic bearings, none (for metal sensors)

WIRING CONNECTIONS

F3.05 sensor wiring connection

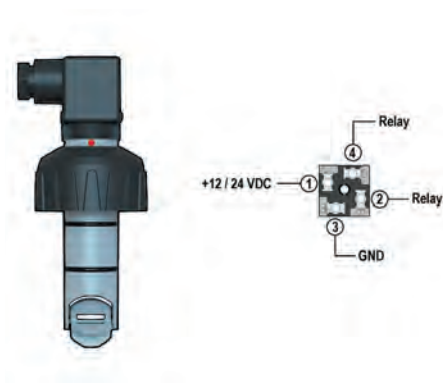

ORDERING DATA

F3.05.XX Paddlewheel Flow Switches							
Part No.	Version	Power supply	Length	Main wetted materials	Enclosure	Flow Rate Range	Weight (gr.)
F3.05.01	Hall	12 to 24 VDC	L0	C-PVC/EPDM	IP65	-	250
F3.05.02	Hall	12 to 24 VDC	L0	C-PVC/FPM	IP65	-	250
F3.05.03	Hall	12 to 24 VDC	L1	C-PVC/EPDM	IP65	-	300
F3.05.04	Hall	12 to 24 VDC	L1	C-PVC/FPM	IP65	-	300
F3.05.05	Hall	12 to 24 VDC	L0	PVDF/EPDM	IP65	-	250
F3.05.06	Hall	12 to 24 VDC	L0	PVDF/FPM	IP65	-	250
F3.05.07	Hall	12 to 24 VDC	L1	PVDF/EPDM	IP65	-	300
F3.05.08	Hall	12 to 24 VDC	L1	PVDF/FPM	IP65	-	300
F3.05.09	Hall	12 to 24 VDC	L0	316L SS/EPDM	IP65	-	600
F3.05.10	Hall	12 to 24 VDC	L0	316L SS/FPM	IP65	-	600
F3.05.11	Hall	12 to 24 VDC	L1	316L SS/EPDM	IP65	-	650
F3.05.12	Hall	12 to 24 VDC	L1	316L SS/FPM	IP65	-	650

FLS F6.60

MAGMETER FLOW SENSOR



The new F6.60 and F6.63 are flow meters without moving mechanical parts which can be applied for the measurement of dirty liquids so long as they are conductive and homogeneous. The F6.60 family can provide three different options: frequency output to be connected to FLS flow monitors, 4-20 mA output for long distance transmission and PLC connection and the new volume pulse output freely settable.

The insertion magmeter family is provided with an USB interface and a dedicated software (freely downloadable from FLS web site) which allows to easily set by a PC all parameters according to specific installation requirements (as full scale and cut off).

The specific design allows an accurate flow measurement over a wide dynamic range in pipe sizes from DN15 (0.5") to DN600 (24").

APPLICATIONS

- Water and waste water treatment
- Raw water intake
- Industrial water distribution
- Textile industry
- Pools, spas and aquariums
- HVAC
- Processing and manufacturing industry
- Sea water applications

MAIN FEATURES

- No moving parts, no wear, maintenance free
- High mechanical resistance
- Accurate measurement of dirty liquids
- Pipe size range: from DN15 (0,5") to DN600 (24")
- Adjustable Flow Rate Range
- Low pressure drop
- User Settable Operating Parameters
- 4-20 mA, frequency or volumetric pulse output
- Bi-directional flow measurement selectable (for F6.60)
- Special versions for salt-water applications (high concentrations of chlorides like sea water) and for high temperature conditions



TECHNICAL DATA

General

- Pipe Size Range: DN15 to DN600 (0.5" to 24")
Please refer to Installation Fitting section for more details
- Max Flow Rate Range:
 - F6.60: from 0,05 to 8 m/s
 - F6.63: from 0,15 to 8 m/s
- Full Scale: 8 m/s (26.24 ft/s)
- Linearity: $\pm 1\%$ of reading + 1,0 cm/s
- Repeatability: $\pm 0.5\%$ of reading
- Enclosure: IP65
- Materials:
 - case: ABS
 - Wetted Materials:
 - sensor body: 316L SS/PVDF; 316L SS/ PEEK; CuNi alloy/PVDF
 - o-rings: EPDM or FPM
 - electrodes: 316L SS or CuNi alloy

Electrical

- Power Supply:
 - 12 to 24 VDC $\pm 10\%$ regulated (reverse polarity and short circuit protected)
- Max Current Consumption: 250 mA
- protective earth: $< 10 \Omega$
- Current output:
 - 4-20 mA, isolated
 - max. loop impedance: $800 \Omega @ 24 \text{ VDC} - 250 \Omega @ 12 \text{ VDC}$
 - positive or negative flow indication
- Solid State Relay output:
 - user selectable as MIN alarm, MAX alarm, Volumetric, Pulse Out, Window alarm, Off
 - optically isolated, 50 mA MAX sink, 24 VDC MAX pull-up voltage
 - max pulse/min: 300
 - hysteresis: User selectable
- Open Collector output (Frequency):
 - Type: Open Collector NPN
 - frequency: 0 – 800 Hz

- max. Pull-up Voltage: 24 VDC
- max. Current: 50 mA, current limited
- compatible with M9.02, M9.50, M9.07, M9.08 and M9.10
- Open Collector output (Direction not available on F6.63):
 - type: Open Collector NPN
 - max. Pull-up Voltage: 24 VDC
 - max. Current: 50mA, current limited
 - flow direction:
 - 0 VDC arrow-wise
 - + VDC anti arrow-wise

Environmental

- Storage Temperature: -30°C to $+80^{\circ}\text{C}$ (-22°F to $+176^{\circ}\text{F}$)
- Ambient Temperature: -20°C to $+70^{\circ}\text{C}$ (-4°F to $+158^{\circ}\text{F}$)
- Relative Humidity: 0 to 95% (non-condensing)
- Fluid conditions:
 - homogeneous liquids, pastes or slurries, also with solid content
 - min electrical conductivity: $20 \mu\text{S/cm}$
 - temperature:
 - PVDF bottom version: -10°C to $+60^{\circ}\text{C}$ (14°F to 140°F)
 - PEEK bottom version: -10°C to $+150^{\circ}\text{C}$ (14°F to 302°F)
- Max. operating pressure:
 - 16 bar @ 25°C (232 psi @ 77°F)
 - 8.6 bar @ 60°C (124 psi @ 140°F)

Standards & Approvals

- Manufactured under ISO 9001
- Manufactured under ISO 14001
- CE
- RoHS Compliant
- EAC

DIMENSIONS

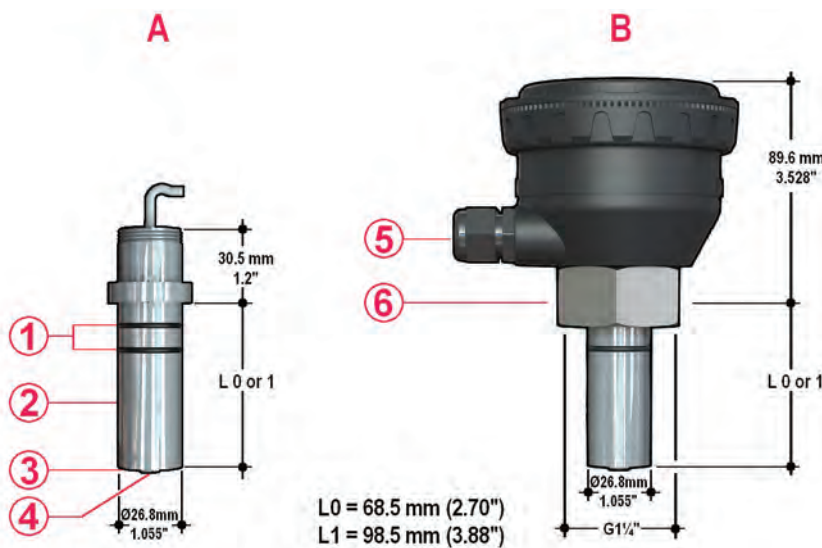

A Sensor body
B F6.60 Magmeter

1 O-Ring (EPDM or FPM)
2 Sensor body (316L SS or CuNi)
3 Isolation Plate (PVDF or PEEK)
4 Electrodes (316L SS or CuNi)

5 Cable Gland
6 316L SS cap for installation into fittings
7 Electronic box

WIRING CONNECTIONS

Rear Terminal View

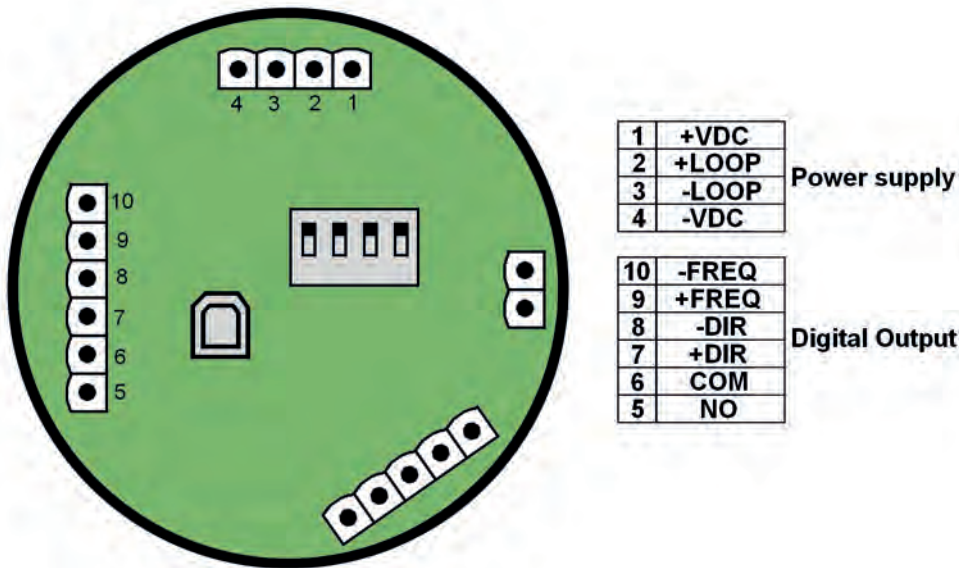

ORDERING DATA

F6.60.XX Magmeter Flow Sensor							
Part No.	Version	Power supply	Length	Main wetted materials	Enclosure	Flow Rate Range	Weight (gr.)
F6.60.09	Blind	12 - 24 VDC	L0	316L SS/ PVDF/ EPDM	IP65	0,05 – 8 m/s bi-directional	950
F6.60.10	Blind	12 - 24 VDC	L0	316L SS/ PVDF/ FPM	IP65	0,05 – 8 m/s bi-directional	950
F6.60.11	Blind	12 - 24 VDC	L1	316L SS/ PVDF/ EPDM	IP65	0,05 – 8 m/s bi-directional	1000
F6.60.12	Blind	12 - 24 VDC	L1	316L SS/PVDF/FPM	IP65	0,05 – 8 m/s bi-directional	1000
F6.60.33	Blind	12 - 24 VDC	L0	CuNi/ PVDF/ EPDM	IP65	0,05 – 8 m/s bi-directional	950
F6.60.34	Blind	12 - 24 VDC	L0	CuNi/ PVDF/ FPM	IP65	0,05 – 8 m/s bi-directional	950
F6.60.35	Blind	12 - 24 VDC	L1	CuNi/PVDF/EPDM	IP65	0,05 – 8 m/s bi-directional	1000
F6.60.36	Blind	12 - 24 VDC	L1	CuNi/ PVDF/ FPM	IP65	0,05 – 8 m/s bi-directional	1000
F6.60.38	Blind	12 - 24 VDC	L0	316L SS/ PEEK/ FPM	IP65	0,05 – 8 m/s bi-directional	950
F6.60.40	Blind	12 - 24 VDC	L1	316L SS/ PEEK/ FPM	IP65	0,05 – 8 m/s bi-directional	1000

F6.63.XX Magmeter Flow Sensor							
Part No.	Version	Power supply	Length	Main wetted materials	Enclosure	Flow Rate Range	Weight (gr.)
F6.63.09	Blind	12 - 24 VDC	L0	316L SS/ PVDF/ EPDM	IP65	0,15 - 8 m/s mono-directional	950
F6.63.10	Blind	12 - 24 VDC	L0	316L SS/ PVDF/ FPM	IP65	0,15 - 8 m/s mono-directional	950
F6.63.11	Blind	12 - 24 VDC	L1	316L SS/ PVDF/ EPDM	IP65	0,15 - 8 m/s mono-directional	1000
F6.63.12	Blind	12 - 24 VDC	L1	316L SS/PVDF/FPM	IP65	0,15 - 8 m/s mono-directional	1000
F6.63.33	Blind	12 - 24 VDC	L0	CuNi/ PVDF/ EPDM	IP65	0,15 - 8 m/s mono-directional	950
F6.63.34	Blind	12 - 24 VDC	L0	CuNi/ PVDF/ FPM	IP65	0,15 - 8 m/s mono-directional	950
F6.63.35	Blind	12 - 24 VDC	L1	CuNi/PVDF/EPDM	IP65	0,15 - 8 m/s mono-directional	1000
F6.63.36	Blind	12 - 24 VDC	L1	CuNi/ PVDF/ FPM	IP65	0,15 - 8 m/s mono-directional	1000
F6.63.38	Blind	12 - 24 VDC	L0	316L SS/ PEEK/ FPM	IP65	0,15 - 8 m/s mono-directional	950
F6.63.40	Blind	12 - 24 VDC	L1	316L SS/ PEEK/ FPM	IP65	0,15 - 8 m/s mono-directional	1000

FLS F6.61

HOT TAP MAGMETER FLOW SENSOR



The new FLS F6.61 Hot Tap Insertion Magmeter Flow Sensor is a flowmeter without moving mechanical parts which can be applied for the measurement of dirty liquids so long as they are conductive and homogeneous. The sensor can provide three different options: frequency output to be connected to FLS flow monitors, 4-20 mA output for long distance transmission and PLC connection and the new volume pulse output freely settable. FLS F6.61 Insertion Magmeter is provided with an USB interface and a dedicated software (freely downloadable from FLS web site) which allows to easily set by a PC all parameters according to specific installation requirements.

The sensor can be assembled in a wide dynamic range of pressurized pipe sizes from DN50 (2") to DN900 (36") using a standard clamp saddle and an isolation ball valve.

APPLICATIONS

- Water distribution
- Leak Detection or Monitoring
- Raw water intake
- Water and waste water treatment
- Ground water remediation
- Irrigation

MAIN FEATURES

- Adjustable sensor position
- Hot-Tap installation
- Operating parameters settable by PC interface
- Pressure intake
- Standard 1 1/4" BSP process connection
- No moving parts, no wear, maintenance free
- Flow Rate Range settable from 0.05 to 8 m/s (0.15 to 25 ft/s)
- Accurate measurement of dirty liquids
- 4-20 mA, frequency or volume pulse outputs
- Bi-directional flow measurement selectable

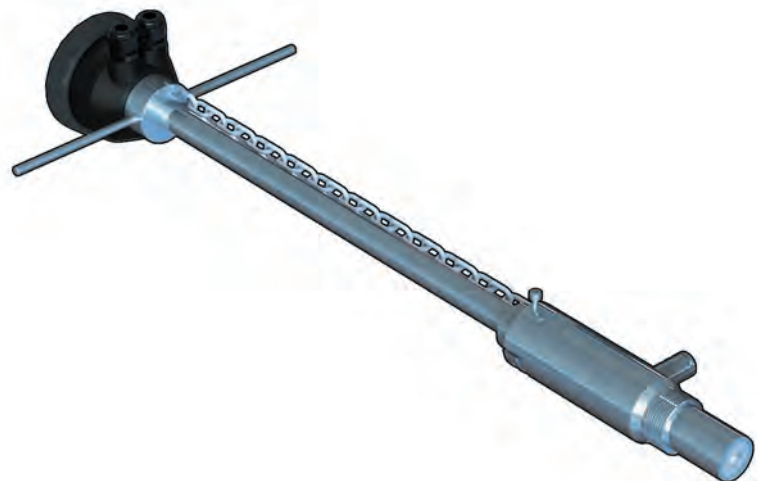

TECHNICAL DATA

General

- Pipe Size Range: DN50 to DN900 (2" to 36"). Special version on request for other sizes. Please refer to Installation Fitting section for more details
- Max Flow Rate Range: from 0.05 to 8 m/s (0.15 to 26.24 ft/s)
- Full Scale: 8 m/s (26.24 ft/s)
- Linearity: $\pm 1\%$ of reading + 1,0 cm/s
- Repeatability: $\pm 0.5\%$ of reading
- Enclosure: IP65
- Materials:
 - case: ABS
 - Wetted Materials:
 - sensor body: 304 SS/PVDF
 - o-rings: EPDM or FPM
 - electrodes: 316L SS

Electrical

- Power Supply:
 - 12 to 24 VDC $\pm 10\%$ regulated (reverse polarity and short circuit protected)
- Max Current Consumption: 250 mA
- protective earth: $< 10 \Omega$
- Current output:
 - 4-20 mA, isolated
 - max. loop impedance: $800 \Omega @ 24 \text{ VDC} - 250 \Omega @ 12 \text{ VDC}$
 - positive or negative flow indication
- Solid State Relay output:
 - user selectable as MIN alarm, MAX alarm, Volumetric, Pulse Out, Window alarm, Off
 - optically isolated, 50 mA MAX sink, 24 VDC MAX pull-up voltage
 - max pulse/min: 300
 - hysteresis: User selectable
- Open Collector output (Frequency):
 - type: Open Collector NPN
 - frequency: 0 – 800 Hz
 - max. pull-up voltage: 24 VDC

- max. current: 50 mA, current limited
- compatible with M9.02, M9.50 and M9.07
- Open Collector output (Direction):
 - type: Open Collector NPN
 - max. Pull-up Voltage: 24 VDC
 - max. Current: 50mA, current limited
 - flow direction:
 - 0 VDC arrow-wise
 - + VDC anti arrow-wise

Environmental

- Storage Temperature: -30°C to $+80^{\circ}\text{C}$ (-22°F to 176°F)
- Ambient Temperature: -20°C to $+70^{\circ}\text{C}$ (-4°F to 158°F)
- Relative Humidity: 0 to 95% (non-condensing)
- Fluid conditions:
 - homogeneous liquids, pastes or slurries, also with solid content
 - Min Electrical Conductivity: $20 \mu\text{S/cm}$
 - Temperature:
 - PVDF bottom version: -10°C to $+60^{\circ}\text{C}$ (14°F to 140°F)
 - PEEK bottom version: -10°C to $+150^{\circ}\text{C}$ (14°F to 302°F)
- Max. operating pressure:
 - 16 bar @ 25°C (232 psi @ 77°F)
 - 8.6 bar @ 60°C (124 psi @ 140°F)

Standards & Approvals

- Manufactured under ISO 9001
- Manufactured under ISO 14001
- CE
- RoHS Compliant
- EAC

DIMENSIONS

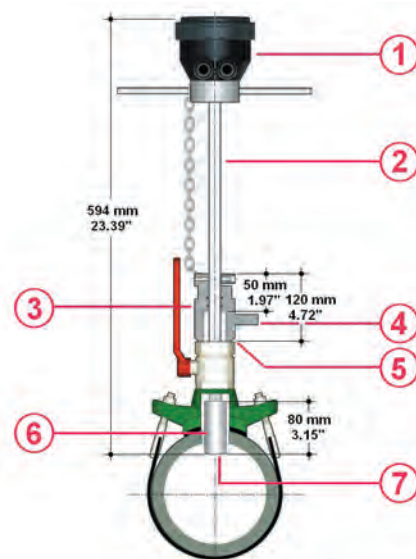

- | | |
|--|--|
| 1 Magmeter electronic device | 5 Process connection 1 1/4" gas threaded |
| 2 Sliding rod | 6 304 SS adjustable sensor body |
| 3 304 SS joint for sensor installation | 7 316 L electrodes and PVDF bottom |
| 4 Pressure intake | |

WIRING CONNECTIONS

Rear Terminal View

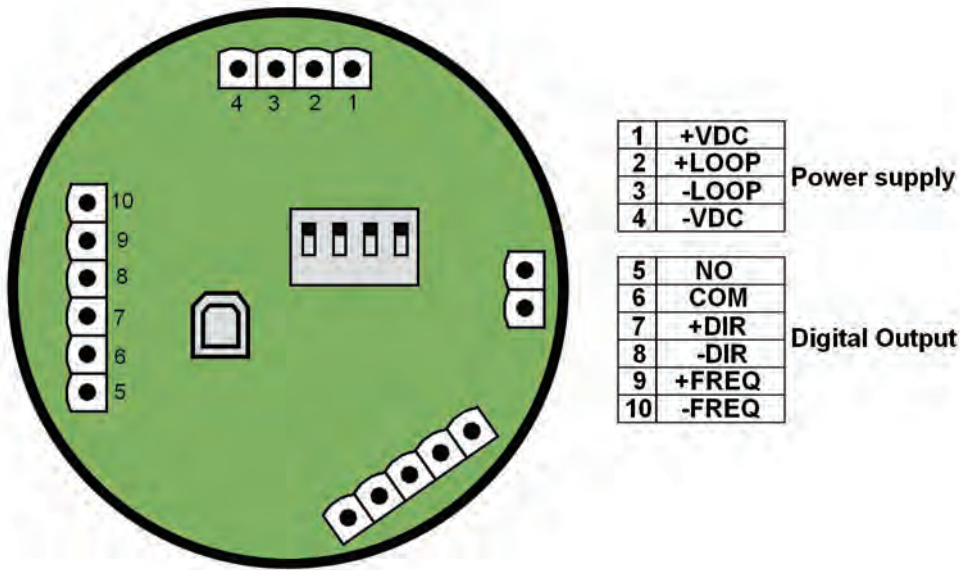

ORDERING DATA

F6.61.XX Hot Tap Magmeter Flow Sensor							
Part No.	Version	Power supply	Length	Main wetted materials	Enclosure	Flow Rate Range	Weight (gr.)
F6.61.01	Hot-tap	12-24 VDC	615mm	304 SS/ PVDF/316L SS	IP65	0,05 – 8 m/s bi-directional	6000



INSTALLATION
& OPERATING GUIDELINES
FOR INSERTION FLOW SENSORS

INSTALLATION GUIDELINES

Insertion Technology Main Features

- All the insertion technology flow sensors are velocity-based flow measurement devices;
- The installation typically requires only a small hole in the pipe for sensor perpendicular mounting;
- Sensors dimension are not pipe size specific: almost independent from pipe cross section.

Flow Sensor Installation

The placement of a flow meter is critical to get an accurate and reliable reading. For a flow meter proper performance it is necessary to check:

- Full pipe at every time;
- Uniform flow velocity into the pipe.

Full Pipe Condition

If the pipe is not full the flow meter will give inaccurate reading even if the sensor is always completely submerged.

Sensor will make the flow rate calculation on the assumption that the pipe is full, leading to overestimation of the flow. A pump intake or an outlet on the bottom of a tank does not necessary ensure the pipe always running full; air can be sucked by pumps or it could remain entrapped when the pipe was empty.

Anyway the flowmeter should be always situated in the lowest point of the pipe and there should be downstream the flowmeter a part of the pipe placed 1*ID higher than where the flow meter is located.

Uniform Flow Velocity

Insertion flow meters measure the velocity of the liquid. It is important the velocity is uniform across the entire cross section of the pipe in the location of the sensor. Flow patterns are distorted both downstream and upstream of any disturbance.

In a pipe, liquid at the edge of the pipe moves slower than towards the center because of friction along the walls.

In a straight run of pipe, area with similar velocities can be depicted as concentric rings.

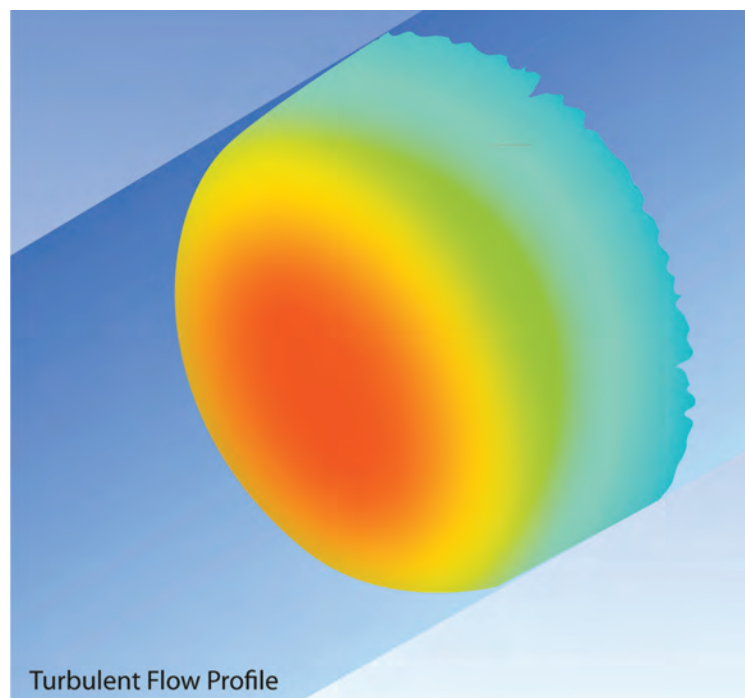

Pipe Location

- The six most common installation configurations shown in fig. 1 help in selecting the best location in the pipeline for paddlewheel flow sensor as well for magmeter flow sensor.
- The three configurations in fig. 2 ensure that the pipe is always full: for a correct measurement the sensor can NOT be exposed to air bubbles at any time.
- The three installations in Fig. 3 should be avoided unless you are absolutely sure the sensor is not exposed to air bubbles.
- In gravity-flow systems the connection to the tank must be designed so the level does not drop below the outlet: this to avoid pipe to draw air in from the tank causing a inaccurate measurement of sensor (see Fig. 4).
- For more information, please refer to EN ISO 5167-1.
- Always maximize distance between flow sensors and pumps.

Fig.1

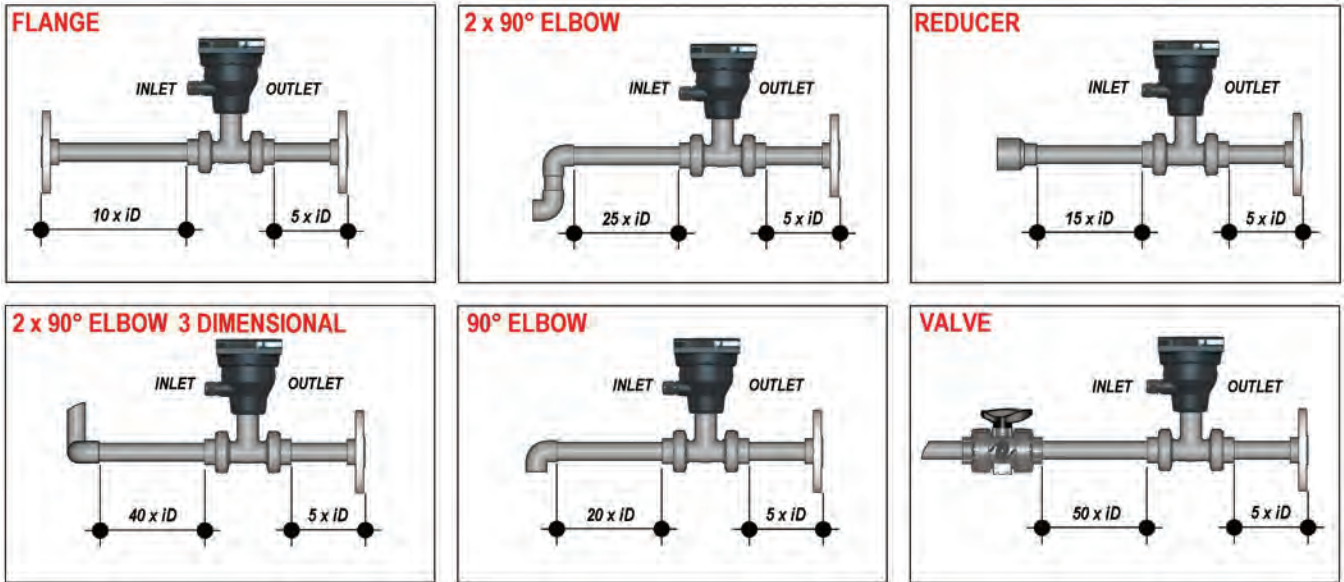

Fig.2

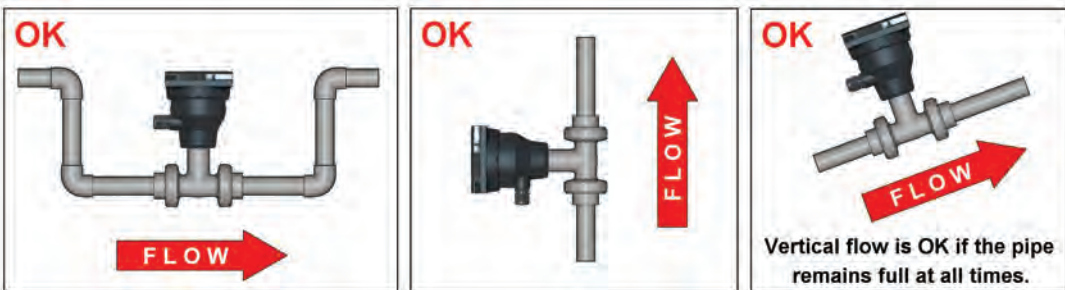

Fig.3

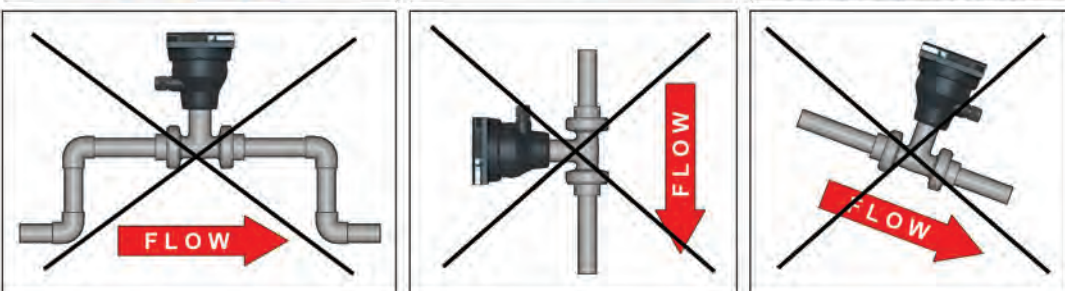
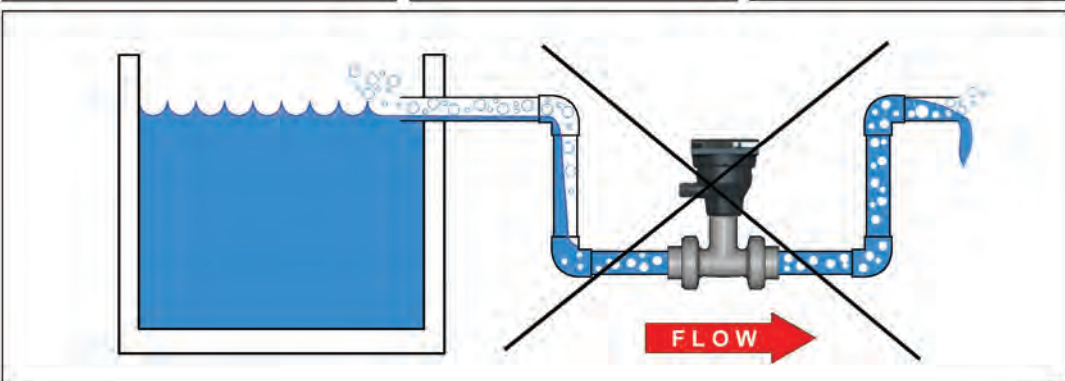

Fig.4



Mounting Positions

Measuring part of sensor (rotor for paddlewheel and pins for magmeter) should be positioned at 12% of ID where, basing on insertion theory, average velocity can be measured.

The reading accuracy of insertion flow sensors can be affected by:

- air bubbles;
- sediments;
- friction between shaft and bearings (only for paddlewheel).

In a horizontal pipe runs, the mounting position to get the best performances is at a 45° angle (*Fig. 3*) to avoid air bubbles as well sediments. Vertical position (*Fig. 2*) can be chosen in case air bubbles are not present. Do not mount the sensor on the bottom of the pipe (*Fig. 1*) if sediments are likely. Do not mount paddlewheel at 90° otherwise friction can affect measurement. Except last consideration about 90° installation, all previous evaluations are valid for magmeter sensor also. Installation in a vertical pipe runs can be done fixing any orientation. Upward flow is preferred to ensure full pipe.

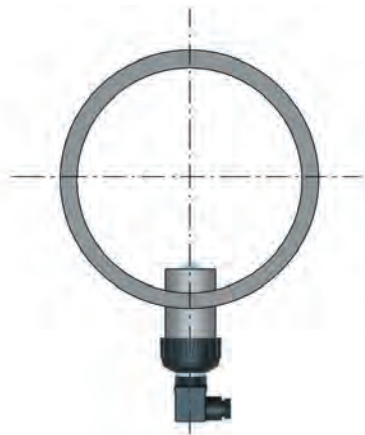

Fig. 1

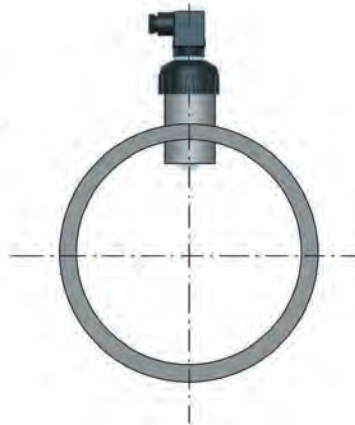

Fig. 2

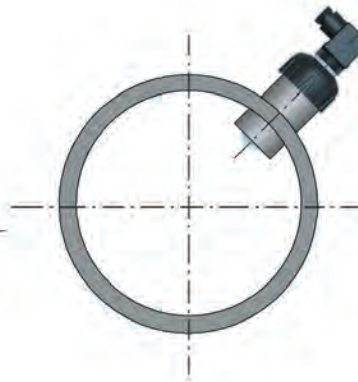

Fig. 3

K-Factor

K factor is a conversion value which has to be fixed in order to convert sensor output (frequency) to a flow rate.

K factor depends on ID of pipe where sensor has been installed and, as each pipe has a specific wall thickness, in general it's necessary to know pipe size (external diameter), pipe material and all info which can determine internal diameter.

Provided k- factors are referred to water so in case sensors are applied to measure a different liquid (with a different viscosity and/or density) a recalibration on-site can be needed using a secondary standard.

Maximize sensor performances

In order to get the maximum accuracy, a recalibration using a reference value of flow rate could help to evaluate a fine tuning of k-factor in according with specifications of installation site. This procedure is strongly suggested when sensors are applied to measure a different liquid than water and in case distances reported into EN ISO 5167-1 can't be respected in the installation.

OPERATING GUIDELINES

Paddlewheel Flow Sensors

Rotor and shaft are in direct contact with the fluid. Since the paddle will spin at a velocity that is directly proportional to the rate of flow, these components will wear over time. Rotors which have operated at high velocity will tend to wear more than units operated at low velocities. Because every fluid has different characteristics, it is difficult to estimate the life expectancy of these components. The chemical compatibilities of each wetted component to the chemical being measured should be considered to choose the best material option. Axles and paddles can be easily replaceable in order to maintain better performances. Avoid using paddlewheel flowmeters for measuring very dirty fluid, or liquids with rocks or pebbles that could break or damage the rotor or the axle. Solids could affect sensor response also modifying friction of shaft. Don't use paddlewheel in case liquid contains fibers. A neglected paddlewheel will in time have degraded accuracy. Even if in case liquid contains solids we suggest to apply a magmeter, you can use a paddlewheel but in such case it's strongly suggested to plan a cleaning procedure of wetted parts periodically. For cleaning procedure use detergent or chemicals compatible with wetted materials.

Magmeter Flow Sensor

In general magmeter flow sensor doesn't need a specific maintenance. In case magmeter is used to measure a very dirty liquid it can be suggested to clean periodically the device with a cloth slightly dampened with water or a liquid compatible with the materials of the device and cloth. Dirty electrodes may cause measurement inaccuracy. Do not use abrasive materials to take maintenance.

Hot tap Insertion Flowmeters

The use of hot tap instrumentation is suggested for installation in pressurized pipes and when it is impossible to stop the flow rate into the pipeline. Hot tap version is available for the magmeter sensor only. Previous advices are valid for these versions also. The sensors designed for hot tap installation are suitable also for pipes with a diameter larger than the maximum covered by traditional sensors (typically DN600/24"). Hot tap sensors have to be combined with hot tap fitting only.



IN LINE ULTRA LOW FLOW AND OVAL
GEAR SENSORS
**LIGHT AND COMPACT DESIGN
FOR RELIABLE LOW FLOW
MEASUREMENT**

FLS ULF

ULTRA LOW FLOW SENSOR



The FLS compact Ultra Low Flow sensors ULF have been for use with every kind of aggressive and solid-free liquids.

The sensor can be fixed to flexible or rigid pipes via 1/4" GAS threaded process connections. The paddlewheel sensor produces a frequency output proportional to the flow velocity that can be easily transmitted and processed.

The ULF sensor offers two different flow ranges starting from 1.5 or 6 l/h (0.0066 or 0.0264 gpm). The construction materials, POM or ECTFE (Halar®), provide high strength and chemical resistance.

APPLICATIONS

- Water treatment
- Chemical industry
- Pharmaceutical industry
- Dosing systems
- Laboratory plants

MAIN FEATURES

- POM or ECTFE (Halar®) wetted parts
- Two flow ranges available:
 - 1.5 - 100 l/h (0.0066 - 0.44 gpm)
 - 6 - 250 l/h (0.0264 - 1.1 gpm)
- High chemical resistance
- Easy mounting

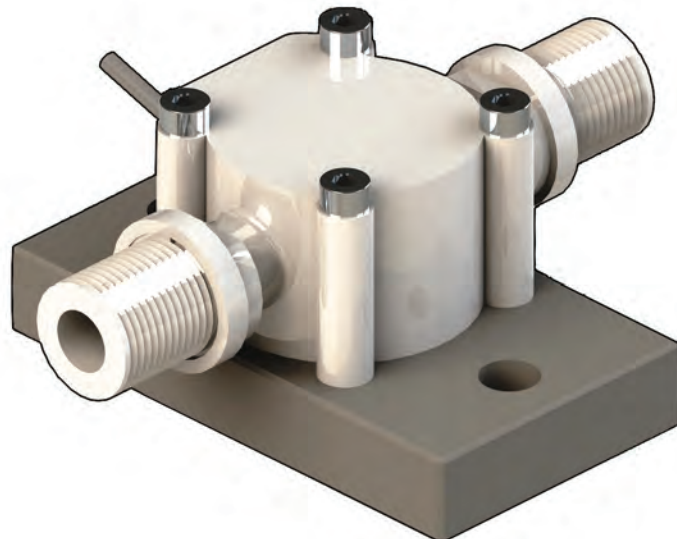

TECHNICAL DATA

General

- Flow Rate Range:
 - ULF01 version: 1.5 to 100 l/h (0.0066 to 0.44 gpm)
 - ULF03 version: 6 to 250 l/h (0.0264 to 1.1 gpm)
- Linearity: $\pm 1\%$ of full scale
- Repeatability: $\pm 0.5\%$ of full scale
- Working Temperature: -10°C to 80°C (14°F to 176°F)
- Working Pressure: 5 bar (70 psi) max @ 22°C (72°F)
- Viscosity of fluid: 1 to 10 cST
- Enclosure: IP65
- Wetted materials:
 - POM version:
sensor body: POM
o-ring: FPM
rotor: POM
shaft: corepoint
magnets: SmCo_5
 - ECTFE version:
sensor Body: ECTFE(Halar®)
o-ring: FPM or KALREZ
rotor: ECTFE (Halar®)
shaft: Sapphire
bearings: Sapphire
- Connections: 1/4" GAS male threaded
- Cable length: 2 m (6.5 ft) standard

Specific for ULF01.H I and ULF03.H

- Supply voltage: 5 to 24 VDC $\pm 10\%$, regulated
- Supply current: $< 15\text{ mA}$ @ 24 VDC
- Output signal: square wave
- Signal type: Push-Pull (for connection to NPN and PNP inputs)
- K-factor:
 - ULF01 version: 8431 Pulses/Liter (31569 Pulses/U.S. Gallon) in linear range from 8 to 100 l/h
 - ULF03 version: 3394 Pulses/Liter (12846 Pulses/U.S. Gallon) in linear range from 15 to 250 l/h

Specific for ULF01.R I and ULF03.R

- Supply voltage: none
- Output signal: square wave
- Output type: Reed Contact
- K-factor:
 - ULF01 version: 2108 Pulses/Liter (7978 Pulses/U.S. Gallon) in linear range from 8 to 100 l/h
 - ULF03 version: 848 Pulses/Liter (3210 Pulses/U.S. Gallon) in linear range from 15 to 250 l/h

Standards & Approvals

- Manufactured under ISO 9001
- Manufactured under ISO 14001
- CE
- RoHS Compliant
- EAC

Pressure Drop

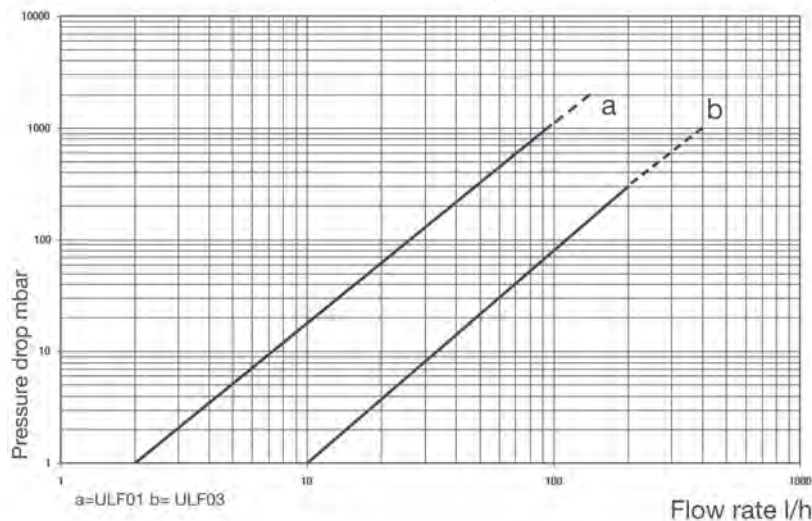

DIMENSIONS

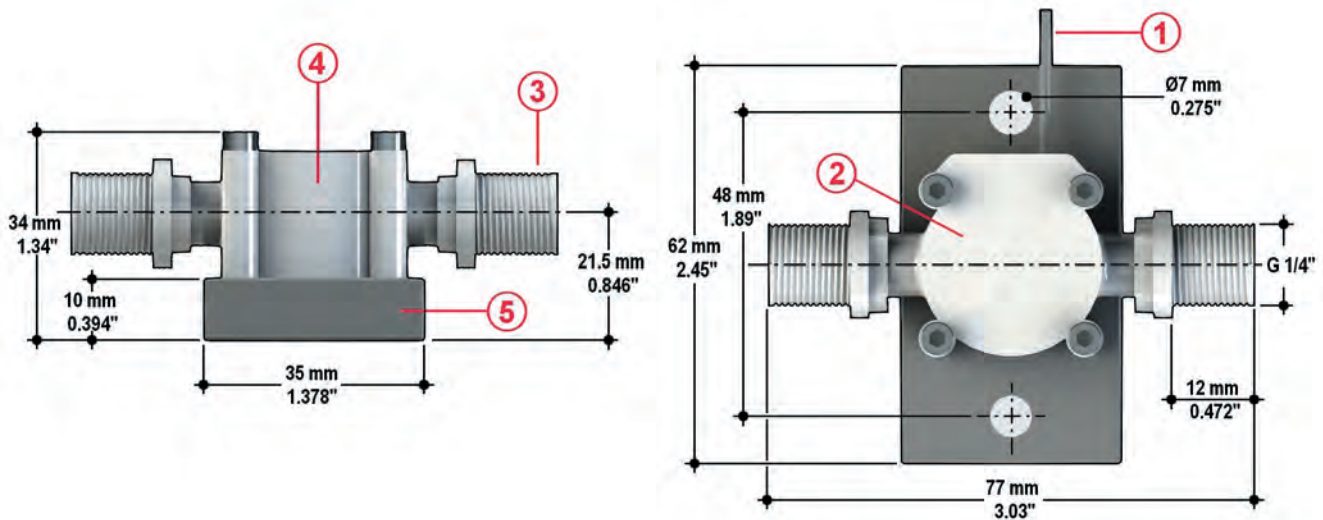

- 1 Electrical cable: 2 m. (6.5 ft) standard
- 2 Completely encapsulated electronics
- 3 Connection (other versions available on request according to body material)
- 4 POM or ECTFE Halar® (registered trademark of Ausimont-Solvay) sensor body
- 5 PP fixing plate

WIRING CONNECTIONS

ULFXX.H Sensor wiring connection

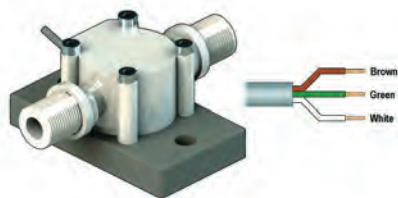

M9.02	
SENSOR	
5	GND
6	IN
7	V+

ULFXX.R Sensor wiring connection

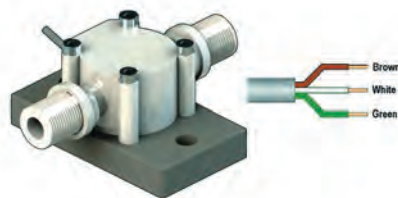

M9.20	
M9.00	
SENSOR	
7	GND
8	IN
9	V+

Wiring connections of ULFXX.H to the other monitors

	M9.50	M9.03	M9.07	M9.08	M9.10
GND	30	30	16	16	37
IN	28	28	14	14	36
V+	27	27	13	13	35

ORDERING DATA

ULFOX.X.X Ultra Low Flow Sensors							
Part No.	Version	Power supply	Length	Main wetted materials	Enclosure	Flow Rate Range	Weight (gr.)
ULF01.H.0	Hall	5 - 24 VDC	77mm	POM / FPM	IP65	1.5 to 100 l/h (0.0066 to 0.44 gpm)	170
ULF01.H.2	Hall	5 - 24 VDC	77mm	ECTFE / FPM	IP65	1.5 to 100 l/h (0.0066 to 0.44 gpm)	200
ULF01.H.3	Hall	5 - 24 VDC	77mm	ECTFE / KALREZ	IP65	1.5 to 100 l/h (0.0066 to 0.44 gpm)	200
ULF01.R.0	Reed	None	77mm	POM / FPM	IP65	1.5 to 100 l/h (0.0066 to 0.44 gpm)	170
ULF01.R.2	Reed	None	77mm	ECTFE / FPM	IP65	1.5 to 100 l/h (0.0066 to 0.44 gpm)	200
ULF01.R.3	Reed	None	77mm	ECTFE / KALREZ	IP65	1.5 to 100 l/h (0.0066 to 0.44 gpm)	200
ULF03.H.0	Hall	5 - 24 VDC	77mm	POM / FPM	IP65	6 to 250 l/h (0.0264 to 1.1 gpm)	170
ULF03.H.2	Hall	5 - 24 VDC	77mm	ECTFE / FPM	IP65	6 to 250 l/h (0.0264 to 1.1 gpm)	200
ULF03.H.3	Hall	5 - 24 VDC	77mm	ECTFE / KALREZ	IP65	6 to 250 l/h (0.0264 to 1.1 gpm)	200
ULF03.R.0	Reed	None	77mm	POM / FPM	IP65	6 to 250 l/h (0.0264 to 1.1 gpm)	170
ULF03.R.2	Reed	None	77mm	ECTFE / FPM	IP65	6 to 250 l/h (0.0264 to 1.1 gpm)	200
ULF03.R.3	Reed	None	77mm	ECTFE / KALREZ	IP65	6 to 250 l/h (0.0264 to 1.1 gpm)	200

IN LINE FLOW SENSORS

FLS F3.80

OVAL GEAR FLOW SENSOR



The FLS Oval Gear Flow sensors F3.80 have been designed following the main industrial application requirements: high mechanical resistance and reliable performances. These sensors are suitable to measure a wide range of viscous solid-free liquids with a very high accuracy and repeatability.

The sensors can be fixed to flexible or rigid pipes via 1/4" GAS threaded process connections. The construction materials, ECTFE (Halar®) or PP or Stainless steel, provide high strength and chemical resistance.

APPLICATIONS

- Chemical industry
- Laboratory plants
- Dosing systems
- Pulsating flows measurement
- High viscosity and not conductive fluid measurement
- Oil measurement

MAIN FEATURES

- Compact dimensions
- Easy installation
- High chemical resistance
- High viscosity fluids measurement
- Low pressure loss

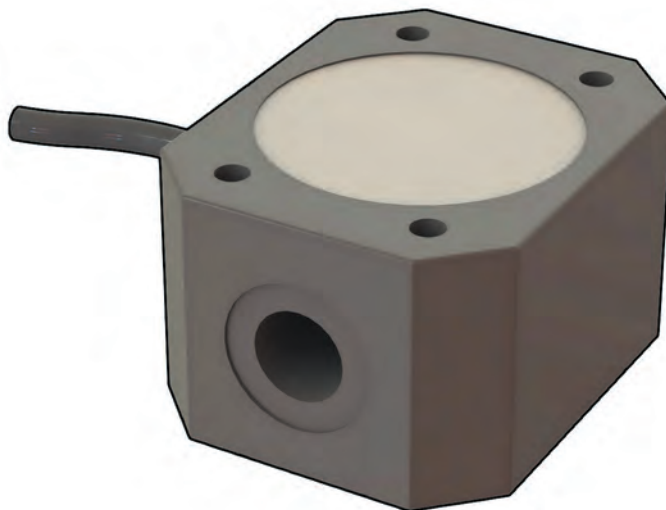

TECHNICAL DATA

General

- Flow Rate Range:
 - F3.81.H: 10 to 100 l/h (0.044 up to 0.44 gpm)
 - F3.82.H: 25 to 150 l/h (0.11 up to 0.66 gpm)
- Linearity: 1 % of full scale
- Repeatability: < 0,3% of full scale
- Working Temperature: -10°C to 60°C (14°F to 140°F)
- Max. Fluid Viscosity : 1000 cP (mPas)
- Working Pressure:
 - PP body:
 - 6 bar (87 psi) @ 25°C (77°F)
 - 3 bar (44 psi) @ 60°C (140°F)
 - ECTFE body:
 - 8 bar (116 psi) @ 25°C (77°F)
 - 5 bar (73 psi) @ 60°C (140°F)
 - SS body:
 - 8 bar (116 psi) @ 60°C (140°F)
- Enclosure: IP65
- Wetted Materials:
 - PP version:
 - sensor body: PP
 - o-ring: FPM
 - gear: ECTFE (Halar)
 - shaft: zircone
 - ECTFE version:
 - sensor body: ECTFE (Halar)
 - o-ring: FPM
 - gear: ECTFE (Halar)
 - shaft: zircone
 - Stainless Steel:
 - sensor body: SS AISI 316L
 - o-ring: FPM
 - gear: ECTFE (Halar)

- shaft: Stainless Steel
- Connections: 1/4" GAS female
- Cable length: 2 m (6.5 ft) standard

Specific for F3.81.H

- Supply voltage: 5 to 24 VDC $\pm 10\%$, regulated
- Supply current: < 15 mA @ 24 VDC
- Output signal: square wave Cmos (NPN / PNP)
- Signal type: Push-Pull (for connection to NPN and PNP inputs)
- K-factor = 5950 Pulses/Liter (22521 Pulses/U.S. Gallon)

Specific for F3.82.H

- Supply voltage: 5 to 24 VDC $\pm 10\%$, regulated
- Supply current: < 15 mA @ 24 VDC
- Output signal: square wave Cmos (NPN / PNP)
- Signal type: Push-Pull (for connection to NPN and PNP inputs)
- K-factor = 3400 Pulses/Liter (12869 Pulses/U.S. Gallon)

Standards & Approvals

- Manufactured under ISO 9001
- Manufactured under ISO 14001
- CE
- RoHS Compliant
- EAC

Pressure Drop

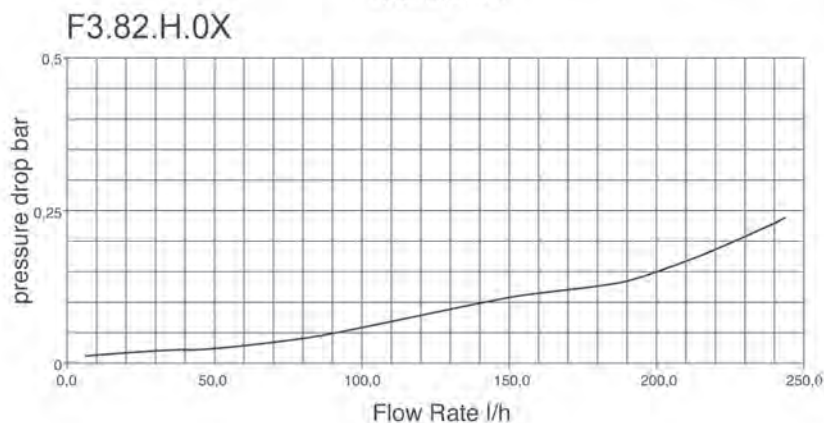
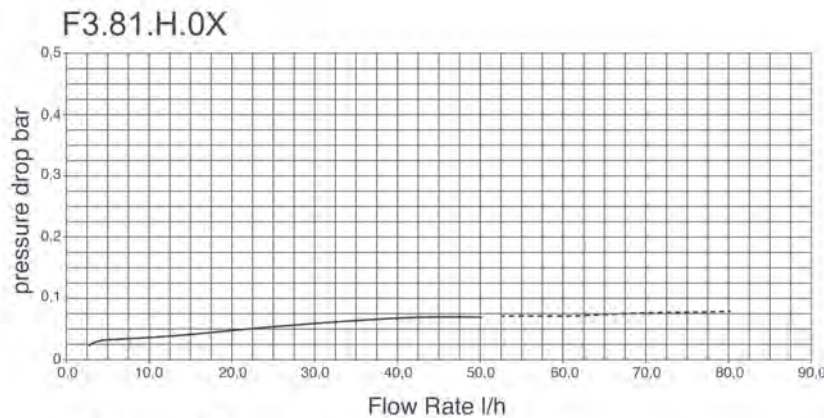

DIMENSIONS

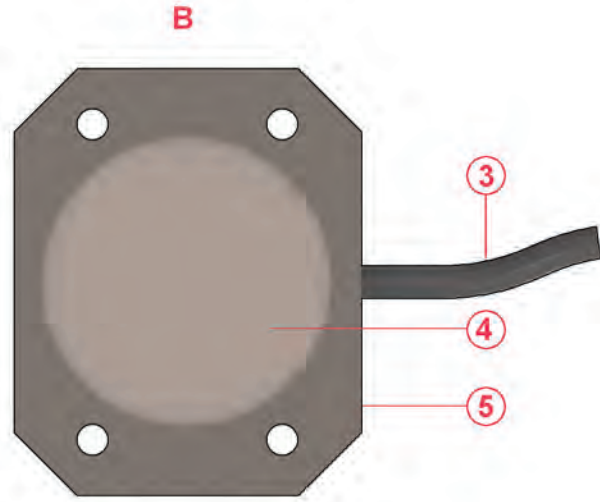
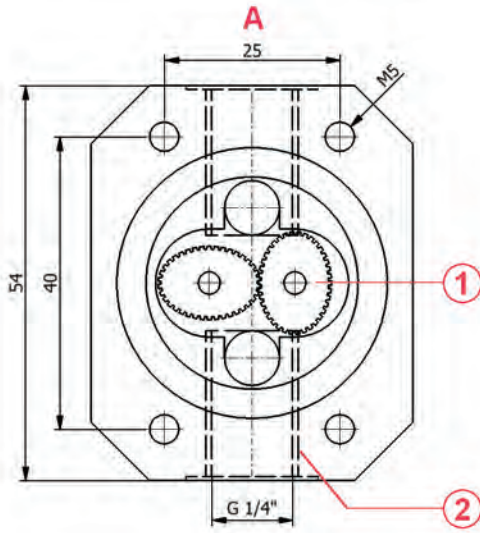

- 1 ECTFE Halar® oval gears
- 2 1/4" GAS threaded pipe connection
- 3 Electrical cable: 2m. (6.5 ft) standard
- 4 Completely encapsulated electronics

- 5 PP or ECTFE Halar® (registered trademark of Ausimont-Solvay) or SS sensor body

WIRING CONNECTIONS

F3.8X.H Sensor Connection

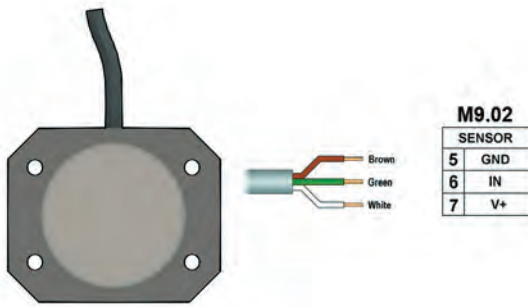

Wiring connections to the other monitors

	M9.50	M9.03	M9.07	M9.08	M9.10
GND	30	30	16	16	37
IN	28	28	14	14	36
V+	27	27	13	13	35

ORDERING DATA

F3.8X.H.XX Oval Gear Flow Sensors							
Part No.	Version	Power supply	Length	Main wetted materials	Enclosure	Flow Rate Range	Weight (gr.)
F3.81.H.01	Hall	5 - 24 VDC	54 mm	PP/ ECTFE/ FPM	IP65	10 to 100 l/h (0.044 to 0.44 gpm)	200
F3.81.H.02	Hall	5 - 24 VDC	54 mm	ECTFE/ ECTFE/ FPM	IP65	10 to 100 l/h (0.044 to 0.44 gpm)	300
F3.81.H.03	Hall	5 - 24 VDC	54 mm	316L SS/ ECTFE/ FPM	IP65	10 to 100 l/h (0.044 to 0.44 gpm)	800
F3.82.H.01	Hall	5 - 24 VDC	54 mm	PP/ ECTFE/ FPM	IP65	25 to 150 l/h (0.11 to 0.66 gpm)	200
F3.82.H.02	Hall	5 - 24 VDC	54 mm	ECTFE/ ECTFE/ FPM	IP65	25 to 150 l/h (0.11 to 0.66 gpm)	300
F3.82.H.03	Hall	5 - 24 VDC	54 mm	316L SS/ ECTFE/ FPM	IP65	25 to 150 l/h (0.11 to 0.66 gpm)	800



INSTALLATION
& OPERATING GUIDELINES
FOR IN LINE FLOW SENSORS

INSTALLATION GUIDELINES

In-line flow sensor can be installed in any position, both horizontally or vertically, although horizontal flow is preferred. A non horizontal installation may cause a greater error in the lower part of the measurement range. Anyway a positioning with a slightly tilt angle is suggested in case bubbles air could be present. Install the sensor with the arrow pointing the direction of the flow. Always maximize distance between sensor and pump. Do not install the sensor immediately downstream of valves, elbows or any kind of obstacles: 150 mm of straight pipe are suggested before and after the sensor. Consider pressure drop correlated to in-line flow sensors, especially in case you use them in a pipeline with a different diameter than 1/4" (male for ULF family and female for F3.80 family). A large pressure drop across in line sensor can prematurely wear and/or damage bearings and/or seals.

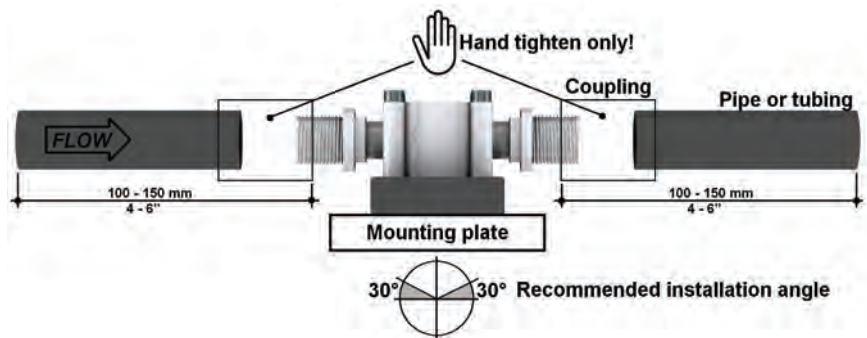

OPERATING GUIDELINES

FLS can supply two different kinds of in-line sensors for low flow rates to cover different applications according to operating range and specific viscosity of liquid.

ULF flow sensor can be generally applied to measure liquids with a viscosity up to 10 cP while F3.80 oval gear flow sensor up to 1000cP. Both sensors have to be applied for the measurement of solid-free liquids as movement parts are present.

Abrasive or dirty liquids can potentially damage the sealing surfaces, the bearings and/or plugging of the sensor. A filter may be required to remove dirt.

Since these types of instruments are mainly used in dosing system, aggressive chemical solutions are very frequently measured. Take care about following cases:

- Chemicals could crystallize if left for a long time into sensor without flow so it's strongly advised to plan a cleaning of sensor in case it's requested a irregular use. For cleaning procedure can be used water as well other solutions compatible with wetted material and with measured chemical.
- Chemicals could release gas so it's strongly advised to pay attention on this issue especially during inoperative period.

Be sure that gas bubbles are removed from liquid flow streams when using in line sensors. For F3.80 family sensors, flow measurements taken with bubbles present will be higher than the true liquid flow because the bubble volumes will be measured as if they were a volume of liquid. For ULF family sensors, flow measurements taken with gas bubble is inaccurate as this presence produces a turbulence into sensor measurement chamber.

In case viscosity of the operating fluid is far from calibrated liquid (water) a recalibration of sensor itself could be necessary to fix the proper k-factor because the different amounts of slippage exhibited by different fluids can cause measurement error. Consider that increasing viscosity decreases slippage and increases the pressure drop across the in line sensor.



BULB AND FLAT pH/ORP
ELECTRODES WITH EPOXY, C-PVC,
RYTON OR GLASS BODY
**THE MOST APPROPRIATE
ELECTRODE FOR EACH APPLICATION**

FLS pH/ORP 200 EPOXY BODY BULB ELECTRODE



This FLS line of electrodes has been designed to provide a cost effective multi-purpose solution for in line or submersion measurement of pH and ORP in a wide range of applications.

Single and double junction versions are available as well as models with or without quick disconnect top caps. Moreover for automatic temperature compensation function (ATC) a pH option with temperature sensor integrated is available. These epoxy body electrodes can stand several applications thanks to the high chemical resistance of the material. A simple and reusable gland can be used for economic electrode in-line mounting while a 1/2" or 3/4" coupler with a pipe extension is enough for submersion mounting. A special version is dedicated to installation on FLS T fitting as well as to FLS clamp saddle adding just a nut.

APPLICATIONS

- Water treatment
- Neutralization systems
- Water quality monitoring
- Swimming Pools and spas
- Aquaculture
- Agriculture and fertilizing systems
- Process control

MAIN FEATURES

- Epoxy body
- Single or double junction technology
- Large gel reference volume
- Easy and quick installation system
- Outline cable or BNC connection
- Version with temperature sensor combined
- Special versions on request
- Low cost fittings



TECHNICAL DATA

General

- Operating Range:
 - pH Electrodes: 0 - 14 pH (0 - 12.3 pH without Na+ error)
 - ORP Electrodes: ± 2000 mV
- Temperature compensation device (for TC model): PT1000
- Pipe Size Range: DN15 to DN100 (0.5" to 4")
- Zero voltage point new electrode performances: 7.00pH ± 0.2pH
- Efficiency new electrode performances: > 97% @ 25°C (77°F)
- Response time new electrode performances:
 - pH: 2 sec for 95% of signal change
 - ORP: application dependent
- Reference:
 - electrolyte: solidified gel 3.5M KCl for single junction versions KCl-KNO3 for double junction versions
- Process Connection:
 - in-line installation with: threaded nipple ½", ¾" or PG13,5 FLS installation fittings
 - submersible installation
- Max Working pressure/ working temperature:
 - 7 bar (100 psi) @ 25°C (77°F)
 - 1 bar (14,5 psi) @ 65°C (149°F)
- Wetted materials:
 - body: epoxy
 - o-ring junction: silicone
 - junction: Pellon®
 - sensing surface: glass membrane (pH) platinum (ORP)
- O-ring: NBR (PH222 CD, PH223 CD, ORP222 CD, ORP223 CD)

Standards & Approvals

- Manufactured under ISO 9001
- Manufactured under ISO 14001
- CE
- EAC

Specific for pH-ORP.200							
Model	Body	Junction material/type	Reference solution	Sensing surface	O-ring	Connection	Max working pressure @ working temperature
PH200C	epoxy	nylon/S.J.	3,5M KCl	glass membrane	-	5 mt. (16.5 ft.) Cable	7 bar @ 25°C/ 1 bar @ 65°C (100 psi @ 77°F/ 14,5 psi @ 149°F)
PH222CD	epoxy	nylon/D.J.	3,5M KCl/ Sat'd KNO3	glass membrane	silicone	Twist-Lock (BNC)	7 bar @ 25°C/ 1 bar @ 65°C (100 psi @ 77°F/ 14,5 psi @ 149°F)
PH223CD	epoxy	nylon/D.J.	3,5M KCl/ Sat'd KNO3	glass membrane	silicone	Twist-Lock (BNC)	7 bar @ 25°C/ 1 bar @ 65°C (100 psi @ 77°F/ 14,5 psi @ 149°F)
ORP200C	epoxy	nylon/S.J.	3,5M KCl	platinum	-	5 mt. (16.5 ft.) Cable	7 bar @ 25°C/ 1 bar @ 65°C (100 psi @ 77°F/ 14,5 psi @ 149°F)
ORP222CD	epoxy	nylon/D.J.	3,5M KCl/ Sat'd KNO3	platinum	silicone	Twist-Lock (BNC)	7 bar @ 25°C/ 1 bar @ 65°C (100 psi @ 77°F/ 14,5 psi @ 149°F)
ORP223CD	epoxy	nylon/D.J.	3,5M KCl/ Sat'd KNO3	platinum	silicone	Twist-Lock (BNC)	7 bar @ 25°C/ 1 bar @ 65°C (100 psi @ 77°F/ 14,5 psi @ 149°F)
PH222CDTC	epoxy	nylon/D.J.	3,5M KCl/ Sat'd KNO3	Glass membrane	-	5 mt (16,5 ft)	7bar @ 25°C/ 1 bar @ 65°C (100 psi @ 77°F/ 14,5 psi @ 149°F)

DIMENSIONS

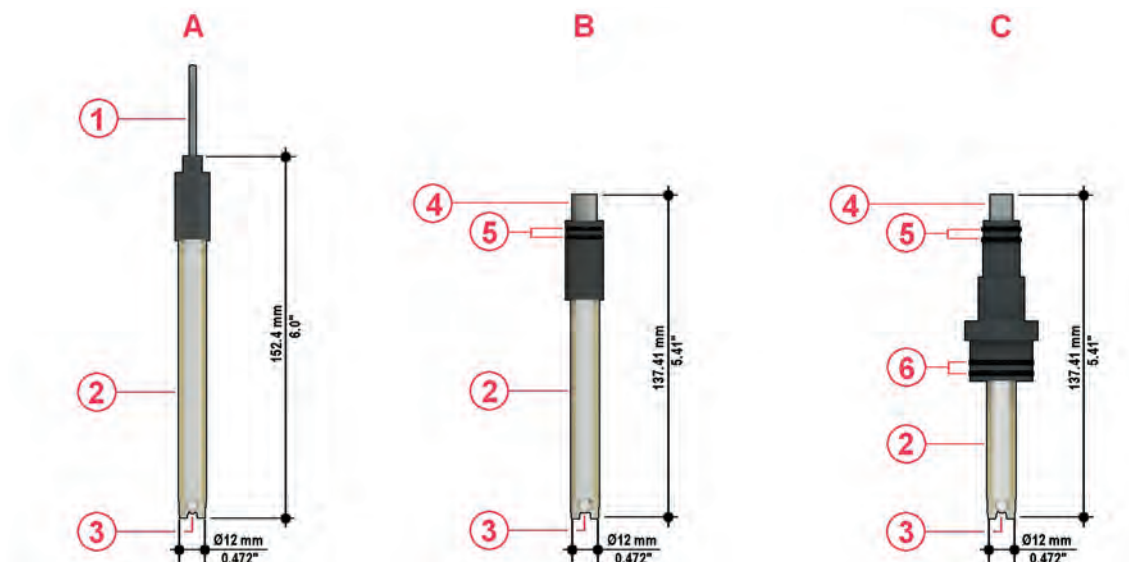

A PH200C PH222CDTC ORP200C
B PH222CD ORP222CD
C PH223CD ORP223CD

1 Cable: 5 mt (6,5 ft.)
2 Epoxy body
3 pH glass bulb
4 BNC connector

5 Buna-N O-rings
6 FPM O-rings

ORDERING DATA

PH2XX Bulb pH Electrodes with epoxy body						
Part No.	Description /Name	Applications/ Operative Range	Cable (sold separately)	Connection	Installation	Weight (gr.)
PH200C	Combination pH/Reference Electrode	0 - 14 pH (0 - 12.3 pH without Na+ error)	not required	5 mt. (16.5 ft.) Cable	EG50P, EG75P, MK150200, MIFV20X05, MIMC20X05	200
PH222CD	Cartridge-type Double Junction Combination pH/Reference Electrode	0 - 14 pH (0 - 12.3 pH without Na+ error)	CN 653, CN 653 TC1	Twist-Lock (BNC)	EG50P, EG75P, MIFV20X05, MIMC20X05	90
PH223CD	Cartridge-type Double Junction Combination pH/Reference Electrode for FLS fittings	0 - 14 pH (0 - 12.3 pH without Na+ error)	CN 653	Twist-Lock (BNC)	F3.SP2.4	100
PH222CDTC	Cartridge-type Double Junction Combination pH/Reference Electrode with Pt1000	0-14 pH (Na+ error >12.3 pH)	Not required	5 mt (16,5 ft)	EG50P, EG75P, MK150200, MIFV20X05, MIMC20X05	220

ORP2XX Bulb ORP Electrodes with epoxy body						
Part No.	Description /Name	Applications/ Operative Range	Cable (sold separately)	Connection	Installation	Weight (gr.)
ORP200C	Combination ORP/Reference Electrode	± 2000 mV	not required	5 mt. (16.5 ft.) Cable	EG50P, EG75P, MK150200, MIFV20X05, MIMC20X05	200
ORP222CD	Cartridge-type Double Junction Combination ORP/Reference Electrode	± 2000 mV	CN 653	Twist-Lock (BNC)	EG50P, EG75P, MIFV20X05, MIMC20X05	90
ORP223CD	Cartridge-type Double Junction Combination ORP/Reference Electrode for FLS fittings	± 2000 mV	CN 653	Twist-Lock (BNC)	F3.SP2.4	100

FLS pH/ORP 400 GLASS BODY BULB ELECTRODE



The FLS 400 line of pH/ORP electrodes with glass body has been designed for fitting a wide range of applications. The ceramic junction guarantees high performances in terms of pressure and temperature. Different types of ceramic junction allow finding the proper solution in according with application needs: annular for a faster response time, 3-diaphragm for higher pressure rate. Moreover the standard double junction prevents the contamination of reference solution granting a long operating time. Version with long outline cable (9 mt) or with head connection (S7) are available.

APPLICATIONS

- Water treatment
- Neutralization systems
- Water quality monitoring
- Process control
- Agriculture and fertilizing systems
- Plating plant and tannery
- Cooling towers and scrubbers

MAIN FEATURES

- Glass body
- Sensors suitable for extreme applications
- Installation easy and cheap
- Cheap adaptors for installations
- Special versions available on request
- High performance electrodes

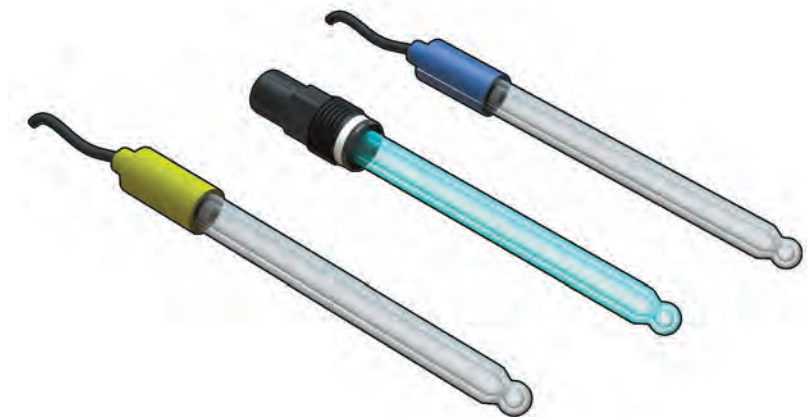

TECHNICAL DATA

General

- Operating range:
 - pH electrodes: 0 - 14 pH (0 - 12.3 pH without Na+ error)
 - ORP electrodes: ± 2000 mV
- Pipe size range: DN15 to DN100 (0.5" to 4")
- Zero point voltage point new electrode performances: 7pH ± 0.2pH
- Efficiency new electrode performances: > 97% @ 25°C (77°F)
- Response time new electrode performances:
 - pH: 2 sec for 95% of signal change
 - ORP: application dependent
- Reference:
 - electrolyte: 3M KCl polymeric gel (different substrates in according with model)
- Process connection:
 - in-line installation with: PG13,5 (PH435CD); threaded nipple 1/2" (PH431CD; ORP431CD)
- Max working pressure/ working temperature:
 - 6 bar (90psi) @ 130°C (266°F); 16 bar (240psi) @ 25°C (77°F) (PH435CD)
 - 2 bar (30psi) @ 100 °C (212 °F); 10bar (100psi) @ 25°C (PH431CD; ORP431CD)
- Wetted materials:
 - body: glass
 - junction: anular ceramic (PH431CD; ORP431CD); double anular ceramic (PH435CD)
 - sensing surface: glass membrane (pH); platinum (ORP)

Standards & Approvals

- Manufactured under ISO 9001
- Manufactured under ISO 14001
- CE
- EAC

Specific for pH-ORP.400							
Model	Body	Junction material/type	Reference solution	Sensing surface	O-ring	Connection	Max working pressure @ working temperature
PH435CD	glass	Ceramic/Double junction	KCl 3M	Glass type H	Silicone	S7	6 bar @ 130°C/ (85 psi @ 266°F)
PH431CD	glass	Ceramic/Double junction	KCl 3M	Glass type GX2	-	9 mt (27 ft) cable	2 bar @ 100°C/ (30 psi @ 212°F)
ORP431CD	glass	Ceramic/Double junction	KCl 3M	Platinum	-	9 mt (27 ft) cable	2 bar @ 100°C/ (30 psi @ 212°F)

DIMENSIONS

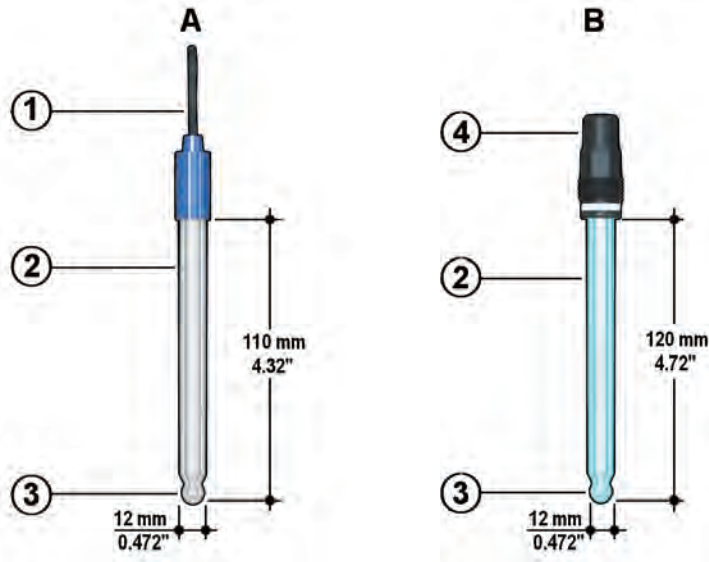

A PH431CD, ORP431CD
B PH435CD

1 Cable: 9mt
2 Glass body
3 pH glass bulb
4 S7

ORDERING DATA

pH4XX Bulb pH Electrodes with glass body						
Part No.	Description /Name	Applications/ Operative Range	Cable (sold separately)	Connection	Installation	Weight (gr.)
PH431CD	Double Junction combination pH/Reference electrode	0 - 13 pH (0 - 12.3 pH without Na ⁺ error)	Not required	9 mt (27 ft)	GEG135	200
PH435CD	Double Junction combination pH/Reference electrode	For high temperature/0 - 14 pH (0 - 12.3 pH without Na ⁺ error)	CE5S7	S7	GEG135 GEG135SE EG135FS EG135FL	200

ORP4XX Bulb ORP Electrodes with glass body						
Part No.	Description /Name	Applications/ Operative Range	Cable (sold separately)	Connection	Installation	Weight (gr.)
ORP431CD	Double Junction combination ORP/ Reference electrode	± 2000 mV	Not required	9 mt (27 ft) cable	GEG135	200

FLS pH/ORP 600

C-PVC BODY FLAT SURFACE ELECTRODE



This is the rugged version of the traditional flat electrodes with an improved self-cleaning effect. Installation and maintenance are easy due to the quick disconnect BNC connectors. Built into the electrode's body is a sealed, gel-filled double junction reference design. This design provides an extra barrier against reference side contamination and allows the electrodes to be used in severe applications prolonging electrode life. The pH-responsive flat glass surface is placed in the center of the measuring surface and surrounded by the flat porous plastic reference junction providing an excellent sample contact. Version with amplified signal for long distance connection and metal pin to ground liquid. A wide range of installation accessories allows in line, submersion or hot tap installation.

APPLICATIONS

- Water & Wastewater treatment
- Pre-chlorination & de-chlorination
- Neutralization systems
- Water quality monitoring
- Ozone treatment
- Cooling towers
- Boiler systems
- Bleach production
- Pulp bleaching
- Aquaculture
- Fruit and vegetables washing
- Textile Dye Process

MAIN FEATURES

- pH and ORP versions
- Flat electrodes
- Double junction technology
- Large gel reference volume
- High protection from process contamination
- Easy and quick installation system
- BNC connector
- In line, submersion or hot tap installation
- Low cost fittings
- HF option (pH) for liquids with HF (max. 2%) inside
- LC option (pH) on request for pure water (<100uS /cm)
- DA option for presence of stray currents or for long distance due to signal amplification

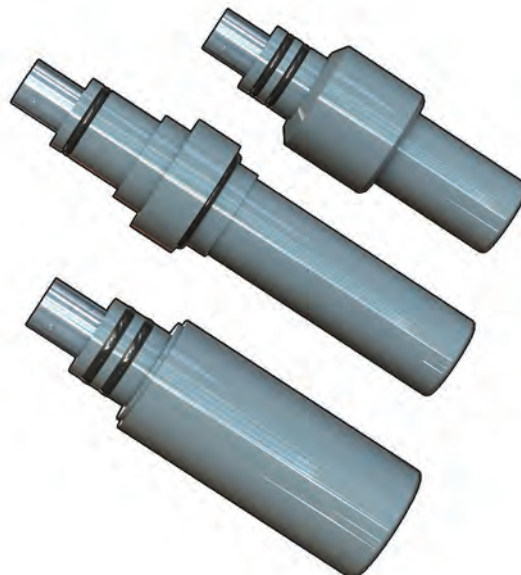

TECHNICAL DATA

General

- Operating Range:
 - pH Electrodes: 0 - 14 pH (0 - 12.3 pH without Na+ error)
 - ORP Electrodes: ± 2000 mV
- Pipe Size Range: DN15 to DN100 (0.5" to 4")
- Zero voltage point new electrode performances: 7.00pH \pm 0.2pH
- Efficiency new electrode performances: > 97% @ 25°C (77°F)
- Response time new electrode performances:
 - pH: < 6 sec for 95% of signal change
 - ORP: application dependent
- Reference
 - type: sealed double junction
 - electrolyte: Solidified Gel 3.5M KCl 0.1M KCl for LC electrode version / solidified gel KCl 3.5M
 - secondary junction: Nylon filament
 - wire: Ag/AgCl.
- Process Connection:
 - In-line installation: threaded nipple $\frac{1}{2}$ ", $\frac{3}{4}$ "
 - FLS installation fittings
 - submersible installation
 - hot-tap installation

- Max Working pressure/ working temperature:
 - 6,7bar@75°C (100psi@170°F)
 - 5,7bar@81°C (85psi@180°F)
- Wetted materials:
 - body: C-PVC (PVDF only on request)
 - reference Junction: porous HDPE
 - sensing surface: glass membrane (pH), platinum sealed in glass (ORP)
 - O-ring: FPM (Viton)

Standards & Approvals

- Manufactured under ISO 9001
- Manufactured under ISO 14001
- CE
- EAC

Specific for pH-ORP.600							
Model	Body	Junction material/type	Reference solution	Sensing surface	O-ring	Connection	Max working pressure @ working temperature
PH660CD	C-PVC	HDPE porous/ D.J.	3,5M KCl	flat glass membrane	FPM	Twist-Lock (BNC)	6,7bar@75°C (100psi@170°F)
ORP660CD	C-PVC	HDPE porous/ D.J.	3,5M KCl	platinum	FPM	Twist-Lock (BNC)	6,7bar@75°C (100psi@170°F)
PH650CD	C-PVC	HDPE porous/ D.J.	3,5M KCl	flat glass membrane	FPM	Twist-Lock (BNC)	6,7bar@75°C (100psi@170°F)
ORP650CD	C-PVC	HDPE porous/ D.J.	3,5M KCl	platinum	FPM	Twist-Lock (BNC)	6,7bar@75°C (100psi@170°F)
PH655CD	C-PVC	HDPE porous/ D.J.	3,5M KCl	flat glass membrane	FPM	Twist-Lock (BNC)	6,7bar@75°C (100psi@170°F)
ORP655CD	C-PVC	HDPE porous/ D.J.	3,5M KCl	platinum	FPM	Twist-Lock (BNC)	6,7bar@75°C (100psi@170°F)

Specific for pH-ORP.600

Model	Body	Junction material/type	Reference solution	Sensing surface	O-ring	Connection	Max working pressure @ working temperature
PH660CDHF	C-PVC	HDPE porous/ D.J.	3,5M KCl	flat glass membrane	FPM	Twist-Lock (BNC)	6,7bar@75°C (100psi@170°F)
PH650CDHF	C-PVC	HDPE porous/ D.J.	3,5M KCl	flat glass membrane	FPM	Twist-Lock (BNC)	6,7bar@75°C (100psi@170°F)
PH655CDHF	C-PVC	HDPE porous/ D.J.	3,5M KCl	flat glass membrane	FPM	Twist-Lock (BNC)	6,7bar@75°C (100psi@170°F)
PH660CDDA	C-PVC	HDPE porous/ D.J.	3,5M KCl	flat glass membrane	FPM	Twist-Lock (BNC)	6,7bar@75°C (100psi@170°F)
ORP660CDDA	C-PVC	HDPE porous/ D.J.	3,5M KCl	platinum	FPM	Twist-Lock (BNC)	6,7bar@75°C (100psi@170°F)
PH650CDDA	C-PVC	HDPE porous/ D.J.	3,5M KCl	flat glass membrane	FPM	Twist-Lock (BNC)	6,7bar@75°C (100psi@170°F)
ORP650CDDA	C-PVC	HDPE porous/ D.J.	3,5M KCl	platinum	FPM	Twist-Lock (BNC)	6,7bar@75°C (100psi@170°F)
PH660CDLC	C-PVC	HDPE porous/ D.J.	0,1M KCl	flat glass membrane	FPM	Twist-Lock (BNC)	6,7bar@75°C (100psi@170°F)
PH650CDLC	C-PVC	HDPE porous/ D.J.	0,1M KCl	flat glass membrane	FPM	Twist-Lock (BNC)	6,7bar@75°C (100psi@170°F)
PH655CDLC	C-PVC	HDPE porous/ D.J.	0,1M KCl	flat glass membrane	FPM	Twist-Lock (BNC)	6,7bar@75°C (100psi@170°F)

DIMENSIONS

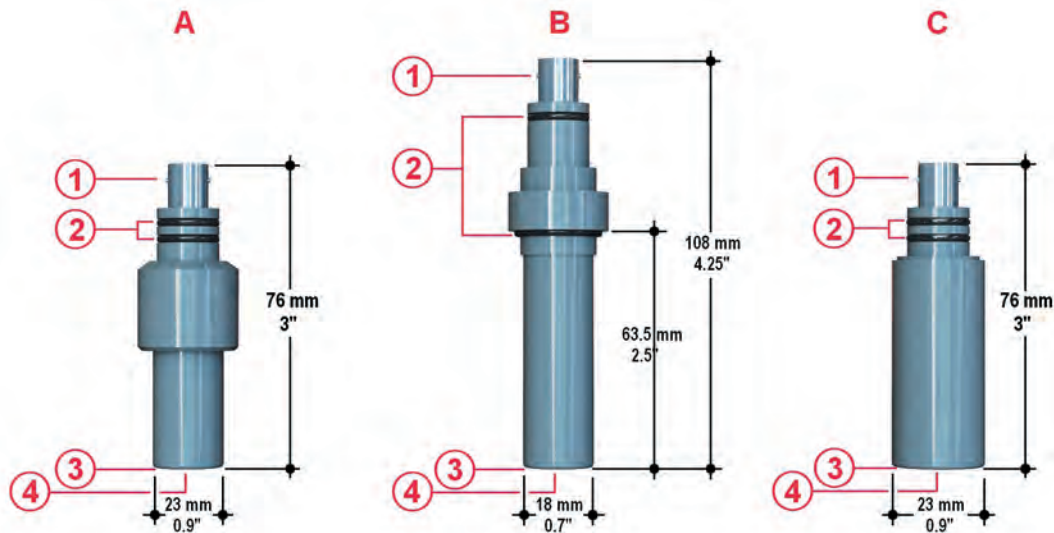

A Submersible PH650, ORP650
 B In-line PH660, ORP660
 C Insertion/Hot-tap PH655, ORP655

1 BNC receptacle
 2 Viton O-rings
 3 Porous HDPE junction
 4 pH glass or platinum

ORDERING DATA

ORP6XX CD Flat surface electrodes						
Part No.	Description /Name	Applications/ Operative Range	Cable (sold separately)	Connection	Installation	Weight (gr.)
ORP660CD	C-PVC Double Junction ORP Combination Flat surface Electrode	-	CN653	Twist-Lock (BNC)	EG66P, MK660	100
ORP650CD	C-PVC Double Junction ORP Combination Flat surface Electrode	-	CN653/CN653 TC1	Twist-Lock (BNC)	MIFV20X05, MIMC20X05	100
ORP655CD	C-PVC Double Junction ORP Combination Flat surface Electrode with pressurized filling gel	-	CN653	Twist-Lock (BNC)	WT675, WT675TC1	100
ORP660CDDA	Ground Loop interrupt Flat Surface pH/ORP combination Electrode	Presence of stray currents/ Signal amplified	CN653	Twist-Lock (BNC)	EG66P, MK660	200
ORP650CDDA	Ground Loop interrupt Flat Surface pH/ORP combination Electrode	Presence of stray currents/ Signal amplified	CN653/CN653 TC1	Twist-Lock (BNC)	MIFV20X05, MIMC20X05	200

ORDERING DATA

pH6XX CD Flat surface electrodes						
Part No.	Description / Name	Applications/ Operative Range	Cable (sold separately)	Connection	Installation	Weight (gr.)
PH660CD	C-PVC Double Junction pH Combination Flat surface Electrode	-	CN653	Twist-Lock (BNC)	EG66P, MK660	100
PH650CD	C-PVC Double Junction pH Combination Flat surface Electrode	-	CN653/CN653TC1	Twist-Lock (BNC)	MIFV20X05, MIMC20X05	100
PH655CD	C-PVC Double Junction pH Combination Flat surface Electrode with pressurized filling gel	-	CN653	Twist-Lock (BNC)	WT675, WT675TC1	100
PH660CDHF	C-PVC Double Junction pH Combination Flat surface Electrode	Liquids with HF (max 2%)	CN653	Twist-Lock (BNC)	EG66P, MK660	100
PH650CDHF	C-PVC Double Junction pH Combination Flat surface Electrode	Liquids with HF (max 2%)	CN653/CN653TC1	Twist-Lock (BNC)	MIFV20X05, MIMC20X05	100
PH655CDHF	C-PVC Double Junction pH Combination Flat surface Electrode with pressurized filling gel	Liquids with HF (max 2%)	CN653	Twist-Lock (BNC)	WT675, WT675TC1	100
PH660CDDA	Ground Loop interrupt Flat Surface pH combination Electrode	Presence of stray currents/ Signal amplified	CN653	Twist-Lock (BNC)	EG66P, MK660	200
PH650CDDA	Ground Loop interrupt Flat Surface pH combination Electrode	Presence of stray currents/ Signal amplified	CN653/CN653TC1	Twist-Lock (BNC)	MIFV20X05, MIMC20X05	200
PH660CDLC	C-PVC Double Junction pH Combination Flat surface Electrode	Liquids with low conductivity (10 μ S/cm <conductivity<100 μ S/cm)	CN653	Twist-Lock (BNC)	EG66P, MK660	100
PH650CDLC	C-PVC Double Junction pH Combination Flat surface Electrode	Liquids with low conductivity (10 μ S/cm <conductivity<100 μ S/cm)	CN653/CN653TC1	Twist-Lock (BNC)	MIFV20X05, MIMC20X05	100
PH655CDLC	C-PVC Double Junction pH Combination Flat surface Electrode with pressurized filling gel	Liquids with low conductivity (10 μ S/cm <conductivity<100 μ S/cm)	CN653	Twist-Lock (BNC)	WT675, WT675TC1	100

FLS pH 800

RYTON BODY FLAT SURFACE ELECTRODE



The new pH electrodes line 870 combines a tough ryton body with auto-cleaning flat pH surface and with a reliable Pt1000 for an accurate measurement in dirty liquid as well as in aggressive solutions. In addition a wide junction improves performances in presence of suspended solids. The new 870 electrodes allow a direct installation by their 3/4" threaded included in the body: in-line installation using the threads on the electrode bottom or submersible installation using the threads on the electrode head. Availability of specific versions for special applications as: horizontal mounting (-HM), low conductive samples (-LC), aggressive solutions (HF<2%)/ low values of pH (-HF).

APPLICATIONS

- Processing and Manufacturing industry
- Chemical processing
- Water treatment processes
- Cooling processes
- Heating processes

MAIN FEATURES

- Temperature sensor combined
- Flat surface electrodes
- Tough Ryton body
- Double threaded body for in line and submersion installation
- Double junction technology
- HM option for horizontal mounting
- HF option for liquids with HF (max 2%)
- LC option for liquid with a conductivity lower than 100µS/cm



TECHNICAL DATA

General

- Operating Range:
 - pH Electrodes : 0-14 pH (0-12,3 pH without Na⁺ error)
- Pipe Size Range: DN15 to DN100 (0.5" to 4")
- Zero voltage point new electrode performances: 7.00pH ± 0.2pH
- Efficiency new electrode performances: > 97% @ 25°C (77°F)
- Response time new electrode performances:
 - pH: < 6 sec for 95% of signal change
- Reference
 - type: sealed double junction
 - electrolyte: Solidified Gel 3.5M KCl 0.1M KCl for LC electrode version / solidified gel KCl 3.5M
 - secondary junction: Nylon filament
 - wire: Ag/AgCl.
- Process Connection:
 - 3/4" NPT threaded body for submersion or in-line installation"
- Max Working pressure/ working temperature:
 - 6,7bar@75°C (100psi@170°F)
 - 5,7bar@81°C (85psi@180°F)
 - 3,3bar@100°C (50 psi@212°F)

- Wetted materials:
 - body: PPS (Ryton®), HDPE, pH Glass, leaded glass
 - reference Junction: porous HDPE
 - sensing surface: glass membrane

Standards & Approvals

- Manufactured under ISO 9001
- Manufactured under ISO 14001
- CE
- EAC

Specific for pH.800							
Model	Body	Junction material/type	Reference solution	Sensing surface	O-ring	Connection	Max working pressure @ working temperature
PH870CDTC	Ryton	HDPE porous/ D.J.	3,5M KCl	Flat glass membrane	-	5 mt (16,5 ft) cable	75°C(170°F)/6,7 bar (100psi), 80°C(180°F)/5,5bar (85psi), 100°C(212°F)/3,3bar (50 psi)
PH870CDTCHM	Ryton	HDPE porous/ D.J.	3,5M KCl	Flat glass membrane	-	5 mt (16,5 ft) cable	75°C(170°F)/6,7 bar (100 psi), 80°C(180°F)/5,5bar (85 psi), 100°C(212°F)/3,3bar (50 psi)
PH870CDTCLC	Ryton	HDPE porous/ D.J.	0,1M KCl	Flat glass membrane	-	5 mt (16,5 ft) cable	75°C(170°F)/6,7 bar (100 psi), 80°C(180°F)/5,5bar (85 psi), 100°C(212°F)/3,3bar (50 psi)
PH870CDTCHF	Ryton	HDPE porous/ D.J.	3,5M KCl	Flat glass membrane	-	5 mt (16,5 ft) cable	75°C(170°F)/6,7 bar (100 psi), 80°C(180°F)/5,5bar (85 psi), 100°C(212°F)/3,3bar (50 psi)

DIMENSIONS



- 1 Cable: 5 m (16,5 ft)
- 2 Ryton body
- 3 Flat pH glass
- 4 Porous HDPE junction
- 5 Temperature sensor inside pH stem
- 6 3/4" NPT threads
- 7 Wrench flat

ORDERING DATA

PH870CDTCXX Ryton Body Flat Surface Electrodes						
Part No.	Description / Name	Applications/ Operative Range	Cable (sold separately)	Connection	Installation	Weight (gr.)
PH870CDTC	Ryton double junction flat surface pH electrode with Pt1000	0-14 pH (0-12,3 pH without Na+ error)	Not required	5 mt (16,5 ft)	3/4" NPT	250
PH870CDTCHM	Ryton double junction flat surface pH electrode with Pt1000	0-14 pH (0-12,3 pH without Na+ error)/ Horizontal mounting	Not required	5 mt (16,5 ft)	3/4" NPT	250
PH870CDTCLC	Ryton double junction flat surface pH electrode with Pt1000	0-14 pH (0-12,3 pH without Na+ error)/ Low conductivity (10 μS/cm<conductivity<100μS/cm)	Not required	5 mt (16,5 ft)	3/4" NPT	250
PH870CDTCHF	Ryton double junction flat surface pH electrode with Pt1000	0-14 pH (0-12,3 pH without Na+ error)/ Presence of HF (max 2%)	Not required	5 mt (16,5 ft)	3/4" NPT	250



INSTALLATION
& OPERATING GUIDELINES
FOR pH/ORP ELECTRODES

INSTALLATION GUIDELINES

In line

In line installation is available for all pH/ORP sensor families. In line installation is suggested for application in a pipe range from DN15 up to DN100. For installation in small pipes pay attention that pH glass is not in contact with pipe surface. pH/ORP electrodes can be installed at 30° maximum from vertical position (except for hot tap version of 600 electrodes family and HM version of 800 electrodes family) being sure that sensor is completely in contact with the measured solution. (Fig. A)

Submersible

Submersible installation is available for 200 electrodes family and for 600 electrodes family. Electrode should be installed near tank outlet away from addition areas in order to measure a representative solution. Sensor should be below the drain level to prevent the electrode from drying out (in case CN653TC1 is applied, take care about positioning of temperature sensor pin). (Fig. B)

Hot-tap

Hot tap installation is available only for a special version of 600 electrodes family (PH655CD, ORP655CD) combined with WT675 or WT675TC1 (in case temperature compensation is requested). Hot tap installation can be useful in case application needs a positioning of electrode different than standard 30° (sensor can work in all positions) as well for in line application where it can't be depressurized during maintenance. Hot tap installation can also solve problem to perform a in-line installation on pipes bigger than DN100. (Fig. C)

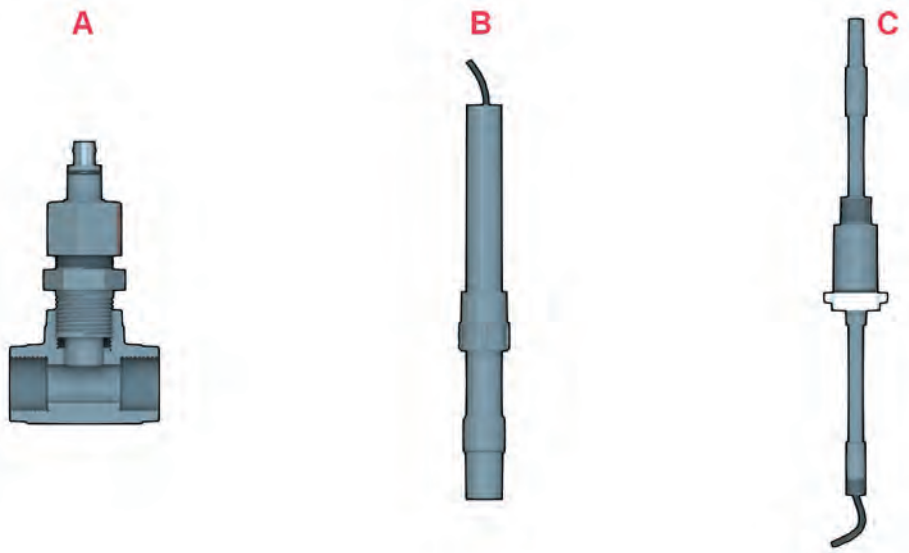

OPERATING GUIDELINES

Storage

When pH readings are made infrequently, for example, several days or weeks apart, the electrode can be stored simply by replacing it in its soaker bottle/protection cap. If the storage solution in the soaker bottle is missed/dried, use 3M KCl or pH 4 buffer.

Care & Cleaning

Coating of an electrode's measuring surface can lead to erroneous readings including shortened span and slow response times. The type of coating determines the type of cleaning technique. Soft coatings can be removed by vigorous stirring, by use of a squirt bottle or, very carefully, by gently wiping with a soft and clean non-abrasive paper or cloth. Do not use any brush or abrasive cleaner on pH glass. Hard Coatings should be chemically removed. The chemical used to remove the coating should be the least harsh chemical that dissolves the coating in 1 or 2 minutes and does not attack the electrode's materials of construction. Abrading or sanding a pH electrode's surface should never be done. ORP/REDOX: electrode may be gently abraded by use of 600 grade wet silicon carbide paper, jeweler's rouge or very fine steel wool, but try to clean chemically before abrading with 600 grade paper.

Reconditioning

When reconditioning is required due to electrode aging (see Operating Instruction), the following chemical treatments can be tried. They are presented in the order of the severity of attack on the pH glass and may not improve (and in some cases actually further deteriorate) electrode performance.

NOTE: Use proper precautions when handling these hazardous chemicals. Ammonium bifluoride and HF (hydrofluoric acid) are extremely hazardous and should only be used by qualified personnel.

1. Immerse the electrode tip in 0.1 N HCl for 15 seconds, rinse in tap water and then immerse tip in 0.1 M NaOH for 15 seconds and rinse in tap water. Repeat this sequence three times and then recheck the electrode's performance. If performance has not been restored, try Step 2.

2. Immerse the tip in a 20% solution of NH₄F-HF (ammonium bifluoride) for 2 to 3 minutes, rinse in tap water and recheck performance.

If performance has not been restored try Step 3.

3. Immerse electrode tip in 5% HF for 10-15 seconds, rinse well in tap water, quickly rinse in 5N HCl, rinse well in tap water and recheck performance.

If performance has not been restored, it is time to get another pH electrode.

ORP/REDOX: clean metal surfaces with a mildly abrasive medium, e.g. toothpaste or very fine scouring powder.

Calibration

Calibration is fundamental to achieve a good accuracy and a reliable measurement.

The frequency of calibration is function of the electrode, the pH meter and the solutions the electrode is exposed to.

Moreover this frequency is correlated to temperature of application and to how much critical the measurement is.

Automatic calibration with standard value of buffer (pH7, pH4, pH10) can be used for general purpose.

Consider that pH 10 buffer is less stable than pH 4 buffer as CO₂ can be dissolved in. So, in case User wants to use the same buffer bottle for several calibration, it's better to prefer pH 4. Don't forget to clean electrode in some water before to dip it in each buffer in order to avoid a buffer contamination.

In case User needs a higher precision at a fixed value, a manual calibration could help this need as User can perform a calibration using buffers around expected value.



POTENTIOMETRIC AND INDUCTIVE
CONDUCTIVITY SENSORS
**A WIDE RANGE OF MEASUREMENT
OPTIONS FROM ULTRA PURE WATER
TO DIRTY LIQUIDS**

FLS C150-200

GRAPHITE OR PLATINUM CONDUCTIVITY SENSOR



The FLS C150-200 conductivity sensors feature graphite or high resolution platinum ring technology. Durable epoxy body construction provides rugged and dependable sensors. These sensors provide accurate and high resolution measurement thanks to the included temperature sensor (Pt100) combined with the ATC (Automatic Temperature Compensation) function of the monitor/transmitter. They can be used for both laboratory and industrial applications. Sensor electrodes are well protected so cell constant can't be easily damaged by solids presence. Three cell constants are available depending on the operating range required. A simple and reusable gland can be used for economic electrode in-line mounting while a 1/2" or 3/4" coupler with a pipe extension is enough for submersion mounting. A specific kit allows to mount these probes on FLS T fitting as well as to FLS clamp saddle.

APPLICATIONS

- Chemical concentrations
- Foods industry
- Steam generation
- Metal finishing and mining
- Textile industry
- Pulp and paper
- Water treatment
- Reverse osmosis
- Softener regeneration
- De-ionization
- Distillation
- Aquaculture
- Agriculture and fertilizing systems

MAIN FEATURES

- Graphite or Platinum measuring surfaces
- Suitable for laboratory, industrial or portable applications so long as liquid is filtered
- In line and submersion installation
- Temperature sensor included
- Cell constant choices of 0.1 and 10



TECHNICAL DATA

General

- Operating Range:
 - C150.01 TC, C200.01 TC: 0.1 $\mu\text{S/cm}$ to 2000 $\mu\text{S/cm}$ (10 $\text{M}\Omega\cdot\text{cm}$ to 500 $\Omega\cdot\text{cm}$)
 - C150.1 TC, C200.1 TC: 1 $\mu\text{S/cm}$ to 20000 $\mu\text{S/cm}$
 - C200.10 TC: 10 $\mu\text{S/cm}$ to 200000 $\mu\text{S/cm}$
- Temp. compensation device (for TC models): Pt100
- Cable length: 5 meter (16 ft.)
- Max. distance electrode-controller (without signal conditioning): 20 meter (66 ft)
- Process Connection:
 - in-line installation with: threaded nipple $\frac{1}{2}$ " or $\frac{3}{4}$ "
 - FLS installation fittings
 - submersible installation
- Working temperature: 0°C to 70°C (32°F to 158°F)
- Max. Working Pressure: 7 bar (100 psi)
- Wetted materials:
 - body: epoxy
 - measuring surface: graphite (C150 version) or platinum (C200 version)

Standards & Approvals

- Manufactured under ISO 9001
- Manufactured under ISO 14001
- CE
- RoHS Compliant
- EAC

Optimal Ranges			
cell constant	0,1	1	10
conductivity range	0,5 ÷ 200 $\mu\text{S/cm}$	0,005 ÷ 10 mS/cm	0,5 ÷ 200 mS/cm
resistivity range	2000 ÷ 5 $\text{k}\Omega\cdot\text{cm}$	200 ÷ 0,1 $\text{k}\Omega\cdot\text{cm}$	2 ÷ 0,005 $\text{k}\Omega\cdot\text{cm}$

DIMENSIONS

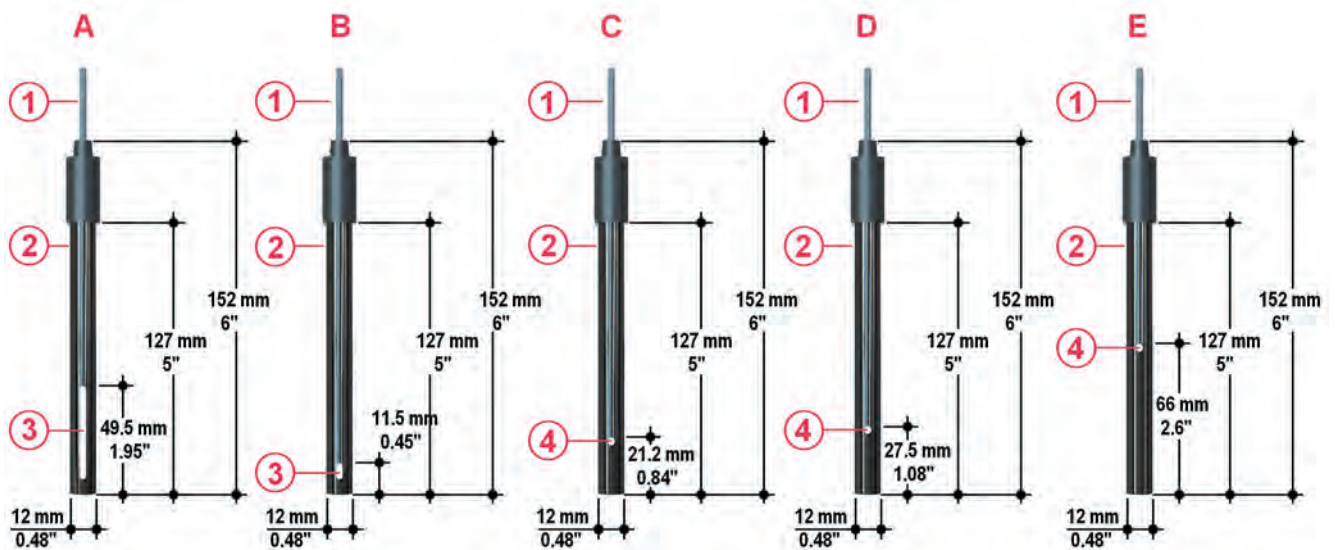

- A C150.01 TC
- B C150.1 TC
- C C200.01 TC
- D C200.1 TC
- E C.200.10 TC

- 1 Cable: 5m (16,5 ft.)
- 2 Epoxy body
- 3 Graphite electrodes
- 4 Platinum electrodes

ORDERING DATA

C150 Epoxy body Conductivity Sensors						
Part No.	Description /Name	Applications/ Operative Range	Cell Constant	Connection	Installation	Weight (gr.)
C150.01TC	Graphite Conductivity Sensor with Temperature Sensor included	0.1 $\mu\text{S}/\text{cm}$ to 2000 $\mu\text{S}/\text{cm}$ (10 $\text{M}\Omega\cdot\text{cm}$ to 500 $\Omega\cdot\text{cm}$)	0,1 Cell	5 m (16,5 ft.)	EG50P, EG75P, MIFV20X05, MIMC20X05	200
C150.1TC	Graphite Conductivity Sensor with Temperature Sensor included	1 $\mu\text{S}/\text{cm}$ to 20000 $\mu\text{S}/\text{cm}$	1,0 Cell	5 m (16,5 ft.)	EG50P, EG75P, MIFV20X05, MIMC20X05, MK150200	200

C200 Epoxy body Conductivity Sensors						
Part No.	Description /Name	Applications/ Operative Range	Cell Constant	Connection	Installation	Weight (gr.)
C200.01TC	Platinum Conductivity Sensor with Temperature Sensor included	0.1 $\mu\text{S}/\text{cm}$ to 2000 $\mu\text{S}/\text{cm}$ (10 $\text{M}\Omega\cdot\text{cm}$ to 500 $\Omega\cdot\text{cm}$)	0,1 Cell	5 m (16,5 ft.)	EG50P, EG75P, MIFV20X05, MIMC20X05	200
C200.1TC	Platinum Conductivity Sensor with Temperature Sensor included	1 $\mu\text{S}/\text{cm}$ to 20000 $\mu\text{S}/\text{cm}$	1,0 Cell	5 m (16,5 ft.)	EG50P, EG75P, MIFV20X05, MIMC20X05	200
C200.10TC	Platinum Conductivity Sensor with Temperature Sensor included	10 $\mu\text{S}/\text{cm}$ to 200000 $\mu\text{S}/\text{cm}$	10,0 Cell	5 m (16,5 ft.)	EG50P, EG75P, MIFV20X05, MIMC20X05	200

FLS C100-300

STAINLESS STEEL CONDUCTIVITY SENSOR



The FLS conductivity sensors with stainless steel electrodes (C100 series) are designed for agriculture application and for light industrial application obviously where sample conditions allow a steel using (water treatment, foods industry and others). This type of sensors are characterized by a considerable ratio performance/price. The combination of temperature sensor with the ATC (Automatic Temperature Compensation) function of the monitor/transmitter allows to get a precise measurement. Moreover a wide number of cell constants grants to choose the best item for specific application. C300 serie has been designed for ultrapure water monitoring (certified cell constant 0,01) and for waste water application (cell constant 10). C300 sensors are completely made in SS ensuring suitability for a wide range of applications.

APPLICATIONS

- Agriculture and fertilizing system
- Water treatment
- Foods industry
- Aquaculture
- Ultrapure water application: production and use

MAIN FEATURES

- Stainless steel measuring surfaces
- Considerable ratio performance/price
- Temperature sensor included
- Wide range of cell constant
- Rugged sensor body in PP (C100)
- Sensor in SS completely (C300)
- C300.001TCCK with certified cell constant

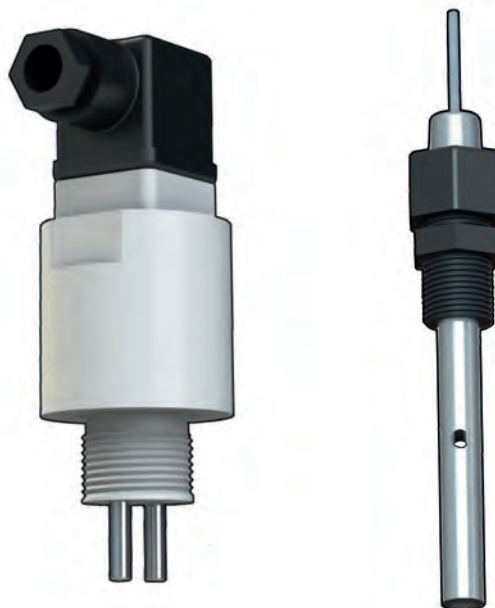

TECHNICAL DATA

General

- Operating range:
 - C300.001 TC: 0,055 $\mu\text{S/cm}$ to 200 $\mu\text{S/cm}$ (18,2 $\text{M}\Omega\cdot\text{cm}$ to 5 $\text{K}\Omega\cdot\text{cm}$)
 - C100.01 TC: 0.1 $\mu\text{S/cm}$ to 2000 $\mu\text{S/cm}$ (10 $\text{M}\Omega\cdot\text{cm}$ to 500 $\Omega\cdot\text{cm}$)
 - C100.02 TC: 0.2 $\mu\text{S/cm}$ to 4000 $\mu\text{S/cm}$
 - C100.1 TC: 1 $\mu\text{S/cm}$ to 20000 $\mu\text{S/cm}$
 - C300.10 TC: 10 $\mu\text{S/cm}$ to 200000 $\mu\text{S/cm}$
- Temperature compensation device (for TC models):
 - Pt 100 (C100TC), Pt1000 (C300TC)
- Cable length:
 - C100.01 TC, C100.02 TC, C100.1 TC: no cable available
 - C300 TC: 3m
- Process connection:
 - C100.01 TC, C100.02 TC, C100.1 TC: $\frac{3}{4}$ " male BSP
 - C300.TC: $\frac{1}{2}$ " male BSP fitting
- Max. Working Temperature:
 - C100.01 TC, C100.02 TC, C100.1 TC : 80°C (176°F)
 - C300TC: 80°C (PP fitting), 120°C (SS fitting)
- Max. Working Pressure:
 - C100.01 TC, C100.02 TC, C100.1 TC: 6 bar (85 psi)
 - C300 TC: 7 bar (PP fitting), 13 bar (SS fitting)
- Wetted materials:
 - body: C100.01 TC, C100.02 TC, C100.1 TC: PP; C300 TC: SS 316

- measuring surface: stainless steel 316

Standards & Approvals

- Manufactured under ISO 9001
- Manufactured under ISO 14001
- CE
- RoHS Compliant
- EAC

Optimal Ranges					
cell constant	0,01	0,1	0,2	1	10
conductivity range	0,055 \pm 20 $\mu\text{S/cm}$	0,5 \pm 200 $\mu\text{S/cm}$	1 \pm 400 $\mu\text{S/cm}$	0,005 \pm 10 mS/cm	0,5 \pm 200 mS/cm
resistivity range	18,18 \pm 0,05 $\text{M}\Omega\cdot\text{cm}$	2000 \pm 5 $\text{k}\Omega\cdot\text{cm}$	1 \pm 0,0025 $\text{M}\Omega\cdot\text{cm}$	200 \pm 0,1 $\text{k}\Omega\cdot\text{cm}$	2 \pm 0,005 $\text{k}\Omega\cdot\text{cm}$

DIMENSIONS

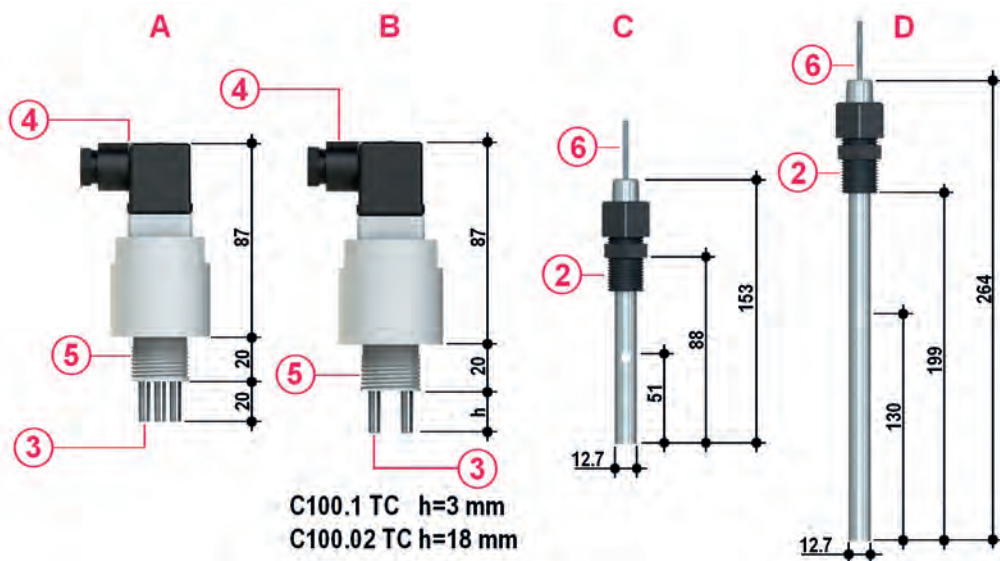

- A C100.01 TC
- B C100.1 TC, C100.02 TC
- C C300.001 TC
- D C300.10 TC

- 2 PP body $\frac{1}{2}$ " male threaded BSP
- 3 Stainless Steel electrodes
- 4 4-Poles connector

- 5 PP body $\frac{3}{4}$ " male threaded BSP
- 6 Cable: 3m (10 ft.)

ORDERING DATA

C100 Stainless Steel Electrodes Conductivity Sensors						
Part No.	Description /Name	Applications/ Operative Range	Cell Constant	Connection	Installation	Weight (gr.)
C100.01TC	PP body sensor with SS Conductivity Electrode and Temperature Sensor included	0.1 $\mu\text{S}/\text{cm}$ to 2000 $\mu\text{S}/\text{cm}$ (10 $\text{M}\Omega \cdot \text{cm}$ to 500 $\Omega \cdot \text{cm}$)	0,1	4 poles connector	$\frac{3}{4}$ " male BSP (parallel threaded)	350
C100.02TC	PP body sensor with SS Conductivity Electrode and Temperature Sensor included	0.2 $\mu\text{S}/\text{cm}$ to 4000 $\mu\text{S}/\text{cm}$	0,2	4 poles connector	$\frac{3}{4}$ " male BSP (parallel threaded)	350
C100.1TC	PP body sensor with SS Conductivity Electrode and Temperature Sensor included	1 $\mu\text{S}/\text{cm}$ to 20000 $\mu\text{S}/\text{cm}$	1	4 poles connector	$\frac{3}{4}$ " male BSP (parallel threaded)	350

C300 Stainless Steel Electrodes Conductivity Sensors						
Part No.	Description /Name	Applications/ Operative Range	Cell Constant	Connection	Installation	Weight (gr.)
C300.001TC	Body sensor and conductivity electrodes in SS	0,055 $\mu\text{S}/\text{cm}$ to 200 $\mu\text{S}/\text{cm}$ (18,2 $\text{M}\Omega \cdot \text{cm}$ to 5 $\text{K}\Omega \cdot \text{cm}$)	0,01	3 m	PP body $\frac{1}{2}$ " male (EG12SS option)	150
C300.001TCCK	Body sensor and conductivity electrodes in SS with certified cell constant	0,055 $\mu\text{S}/\text{cm}$ to 200 $\mu\text{S}/\text{cm}$ (18,2 $\text{M}\Omega \cdot \text{cm}$ to 5 $\text{K}\Omega \cdot \text{cm}$)	0,01	3 m	PP body $\frac{1}{2}$ " male (EG12SS option)	150
C300.10TC	Body sensor and conductivity electrodes in SS	10 $\mu\text{S}/\text{cm}$ to 200000 $\mu\text{S}/\text{cm}$	10	3 m	PP body $\frac{1}{2}$ " male (EG12SS option)	150

FLS C6.30

INDUCTIVE CONDUCTIVITY TRANSMITTER



FLS C6.30 is a family of inductive conductivity transmitters which are made by a 4-20mA output device (two wire technology) integrated onto an inductive conductivity sensor. This type of measurement technology allows a broad range of applications especially to measure high values of conductivity (till 1000 millisiemens) in aggressive fluids (C-PVC is the only wetted material). As no electrodes are directly in contact with liquid, a reliable and stable measurement is guaranteed for a long operating time. A proper automatic temperature compensation (ATC) is granted by a Pt100 integrated into instrument body. The isolated 4-20mA output is perfect for direct connections to PLCs or data loggers without any extra interfaces. Transmitter as well as temperature sensor are supplied already calibrated.

APPLICATIONS

- Water treatment
- Waste water treatment
- Cooling towers
- Scrubber systems
- Metal finishing Coating and corrosion fluid measurement

MAIN FEATURES

- Corrosion & coating resistant
- Compact transmitter
- No calibration required
- Easy installation
- Pt100 sensor integrated
- Suitable for submersible installation

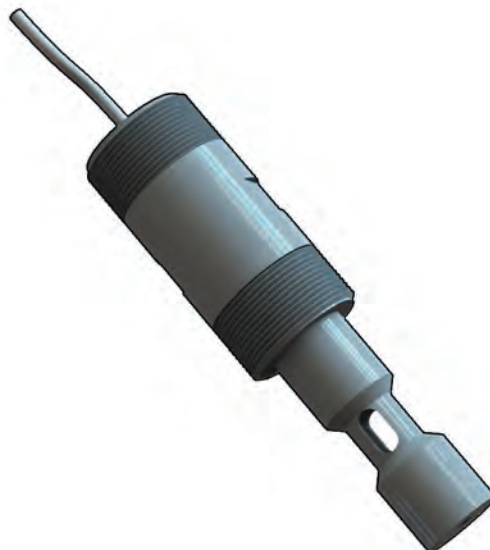

TECHNICAL DATA

General

- Body Material: C-PVC
- Body length: 207mm
- Enclosure: IP68
- Power supply: 10-30 VDC regulated
- Max Power Consumption: <22mA
- Max Working pressure/Working Temperature:
 - 10bar (145psi) @ 25°C (77°F)
 - 6bar (87psi) @ 50°C (122°F)
- Process connection: 1 ½" male NPT

Standards & Approvals

- Manufactured under ISO 9001
- Manufactured under ISO 14001
- CE
- RoHS Compliant
- EAC

DIMENSIONS

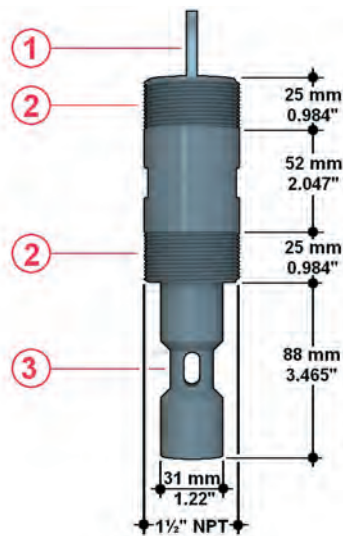

- 1 Cable:3 mt (9 ft.)
- 2 1 ½" male NPT
- 3 C-PVC coating

ORDERING DATA

C6.30 Inductive Conductivity Transmitters						
Part No.	Description /Name	Applications/ Operative Range	Cell Constant	Connection	Installation	Weight (gr.)
C6.30.01	C-PVC Inductive Conductivity Transmitter with Temperature Sensor included	0-10 mS/cm	-	3 mt	1 1/2" NPT male threaded	550
C6.30.02	C-PVC Inductive Conductivity Transmitter with Temperature Sensor included	0-100 mS/cm	-	3 mt	1 1/2" NPT male threaded	550
C6.30.03	C-PVC Inductive Conductivity Transmitter with Temperature Sensor included	0-1000 mS/cm	-	3 mt	1 1/2" NPT male threaded	550



INSTALLATION
& OPERATING GUIDELINES
FOR CONDUCTIVITY SENSORS

INSTALLATION GUIDELINES

In line

In line installation is available for all conductivity sensor families. It's possible to perform 2 different types of in-line installation: vertically on a straight pipeline using a proper T fitting or through the side of a T fitting. The first installation should be performed mounting upside down (or at least at 45°) as this condition help to prevent air entrapment. The second installation type is preferred since this configuration reduces the probability of entrapped air bubbles and provides the best continuous sampling of the fluid. Pay attention that the electrodes of the sensor are completely dipped into a representative solution (not in a dead volume). Conductivity sensors can work properly in any direction.

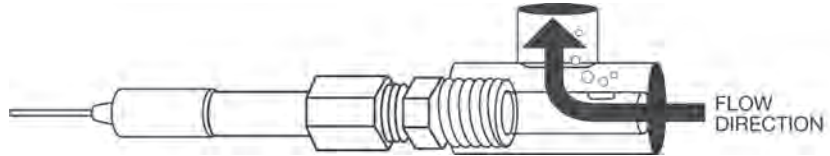

Submersible

Submersible installation is available for C150/C200 sensor family. Sensor should be installed near tank outlet away from addition areas in order to measure a representative solution.



OPERATING GUIDELINES

Care & Cleaning

All conductivity sensors can be cleaned with a gentle detergent. C150/C200 sensor families can be cleaned using a 5% HCl solution also. Do not sand or abrade the electrodes surface as abrasion changes the surface area and will cause erroneous readings. Anyway every solution compatible with electrodes material and sensor body material can be used.

Calibration

Calibration is fundamental to achieve a good accuracy and a reliable measurement. The frequency of calibration is a function of the sensor and the solutions that conductivity sensor has to measure. Moreover this frequency is correlated to how much critical the measurement is. Pay attention that air bubbles are not present during calibration since such condition could cause a erroneous readings. As temperature affects strongly conductivity measurement, pay attention on:

- reference temperature (it should be the same for monitor and for calibration solution)
- temperature compensation: if it's activated User should use conductivity value of calibration solution at reference temperature; if it's not activated User should refer to conductivity value of calibration solution at calibration solution temperature.
- temperature compensation factor: check if it's proper for calibration/ measured solution.



MISCELLANEA
**A MULTIPURPOSE FAMILY
OF INSTRUMENTS READY
TO BE EXPANDED**

FLS HF6

LEVEL AND PRESSURE TRANSMITTER



FLS HF6 is a new family of transmitters suitable for hydrostatic level/depth measurement and for pressure monitoring.

PVDF body and ceramic diaphragm with FPM sealing system offer a smart combination of valuable wetted materials.

The semi-flush diaphragm can work properly and for long time in pasty media and with liquids tending to crystallize.

HF6 family can be also the finest choice for clean water applications in case customer would maximize operating time.

The compact design can fit all main applications related to aggressive and corrosive liquids granting different solutions of installation: screw-in (combined with a FIP valve or fitting), submersed with PUR cable running into pipe and submersed with PUR/FEP cable in contact with liquid. Other operating ranges and selectable length of cable in addition to sealing material options offer a customized solution to match the customer needs in the best possible way.

APPLICATIONS

- Storage Tank management
- Liquid inventory control
- Over flow detection
- Water/Wastewater monitoring
- Chemicals processing
- Tank farm management
- Water recycling

MAIN FEATURES

- Level/Pressure/Depth measurement provided by the same transmitter
- Level measurement not affected by foam or vapour
- Premium combination of wetted materials
- Semi flush ceramic diaphragm for a long-lasting operating time
- Options for gauge pressure and for absolute pressure
- Flexible submersible installation (with or without conduit)
- Other operating ranges available on request: full scale @ 600mbar, 1600mbar, 2500mbar, 4000mbar, 6000mbar, 25bar, 40bar (gauge or absolute mode).



TECHNICAL DATA

General

- Operating range: see the table "Specific for HF6"
- Accuracy*: $\leq \pm 0.5$ % FSO *Accuracy according to IEC 60770 – limit point adjustment (non-linearity, hysteresis, repeatability)
- Wetted Materials:
 - Pressure port / housing: PVDF
 - Cable: 8 m PUR (FEP option)
 - Max cable length: 700 m
 - Seals: FPM (EPDM option)
 - Diaphragm ceramics: Al_2O_3 96%
 - Electromagnetic compatibility emission and immunity according to EN 61326
- Thermal effects (Offset and Span) / Permissible Temperatures:
 - Thermal error: $\leq \pm 0.2$ % FSO / 10 K
 - Compensated range: -25 °C to 85 °C
 - Permissible temperatures:
 - * Medium: -30 to 125 °C
 - * Electronics / environment: -30 to 85 °C
 - * Storage: -30 to 100 °C
- Mechanical stability:
 - Vibration (25 to 2000 Hz) according to DIN EN 60068-2-6
 - Shock 500 g / 1 msec according to DIN EN 60068-2-27
- Enclosure: IP68

- 1*Current output: 4-20mA
- Max loop impedance: $R_{max} = [(V_s - V_s \text{ min}) / 0.02 \text{ A}] \Omega$
- Influence effects:
 - supply: 0.05 % FSO / 10 V
 - load: 0.05 % FSO / k Ω
- Response time: ≤ 10 msec
- Long term stability: $\leq \pm 0,3$ % FSO / year at reference conditions
- Thermal error (Offset and Span): $\leq \pm 0.2$ % FSO/10 K
- Permissible Temperature Range: -25 °C to 85 °C
- Vibration: 10 g RMS (25 ... 2000 Hz) according to DIN EN 60068-2-6
- Shock 500 g / 1 msec according to DIN EN 60068-2-27

Environmental

- Operating temperature:
 - medium: -30 to 125 °C (-22 to +257 °F) - referred to in line installation
 - electronics / environment: -30 to +85 °C (-22 to +185 °F)
- Storage temperature: -30 to +100 °C (-22 to +212 °F)

Standard & Approvals

- Manufactured under ISO9001
- CE

Electrical

- Supply voltage (VS): 8 to 32 VDC
- Current consumption: max. 25 mA

Specific for HF6					
Model	Nominal pressure gauge [bar]	Level [mH ₂ O]	Overpressure [bar]	Burst pressure [bar]	Vacuum resistance [bar]
HF6.004	0.4	4	1	2	PN \geq 1 bar: unlimited vacuum resistance PN < 1 bar: on request
HF6.010	1	10	2	4	
HF6.100	10	100	20	30	
HF6.160	16	160	40	50	

Maximum Operating Pressure/Temperature (using thread for coupling)

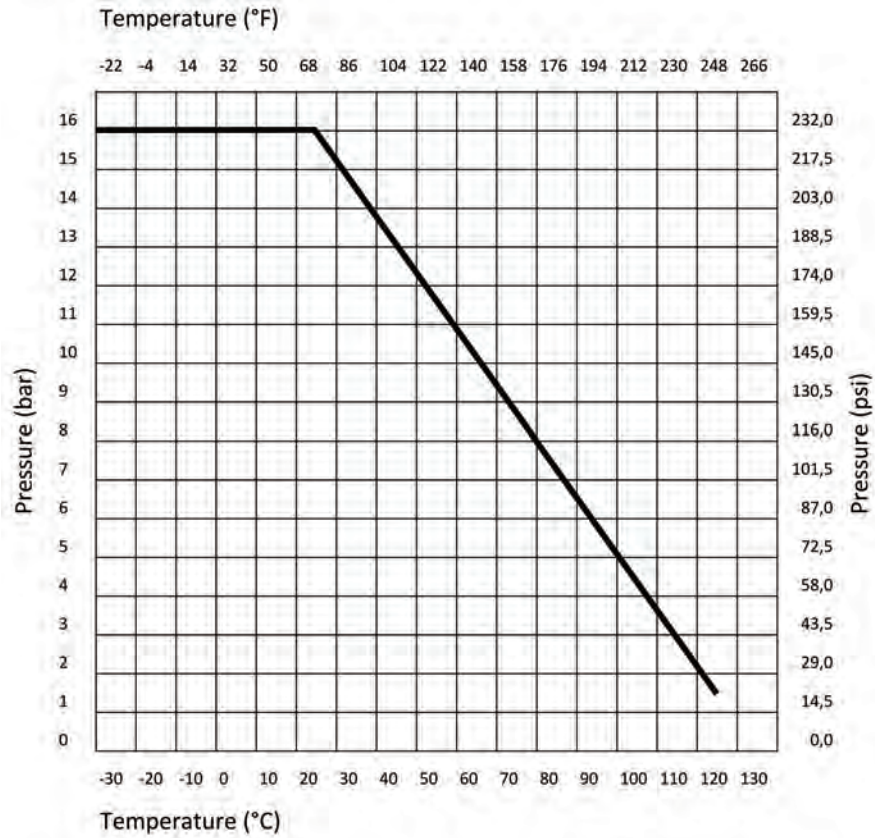

Data refers to water and non-hazardous fluids for which the material is classified as chemically resistant (25 years lifetime).

DIMENSIONS

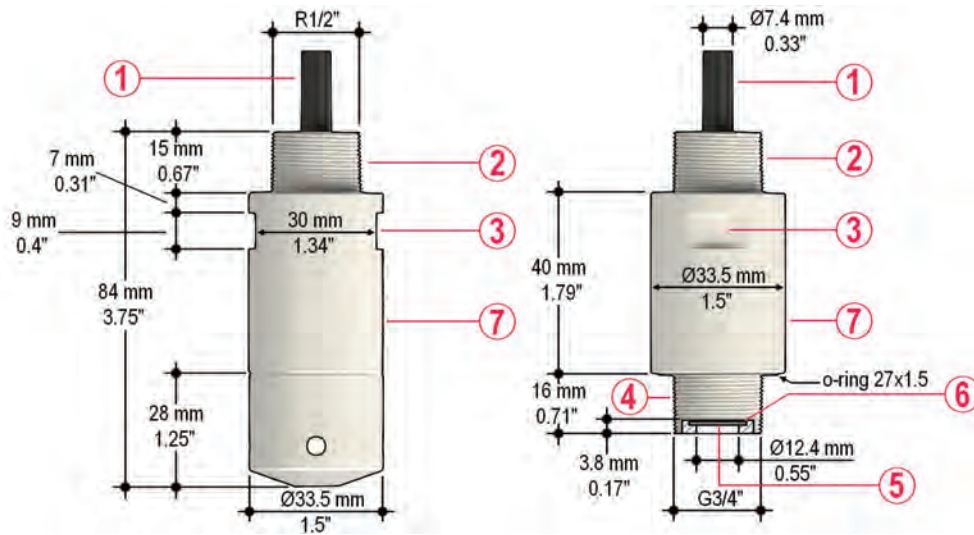

- 1 Cable PUR 8m
- 2 Thread (R 1/2")
- 3 Wrench flat
- 4 Thread (G 3/4")
- 5 FPM O-ring
- 6 Ceramic diaphragm
- 7 Body: PVDF

ORDERING DATA

HF6.XXX Level and Pressure Transmitter								
Part No.	Description/ Name	Applications/ Operative Range	Process connection	Main Wetted Materials	Measuring Mode	Diaphragm	Cable	Weight (g)
HF6.004	Level/Pressure Hydrostatic Transmitter	0-400mbarg	STD: ¼" G (class A) SUBMERSED: ½" R (class A)	PVDF, PUR, FPM, ceramic	Relative Pressure	Ceramic/ Semi flush	PUR 8m	550
HF6.010	Level/Pressure Hydrostatic Transmitter	0-1000mbarg	STD: ¼" G (class A) SUBMERSED: ½" R (class A)	PVDF, PUR, FPM, ceramic	Relative Pressure	Ceramic/ Semi flush	PUR 8m	550
HF6.100	Level/Pressure Hydrostatic Transmitter	0-10barg	STD: ¼" G (class A) SUBMERSED: ½" R (class A)	PVDF, PUR, FPM, ceramic	Relative Pressure	Ceramic/ Semi flush	PUR 8m	550
HF6.160	Level/Pressure Hydrostatic Transmitter	0-16barg	STD: ¼" G (class A) SUBMERSED: ½" R (class A)	PVDF, PUR, FPM, ceramic	Relative Pressure	Ceramic/ Semi flush	PUR 8m	550

Other versions available:

- SS AISI630 body equipped with SS AISI630 flush diaphragm and ranges from 0-1bar up to 0-100bar (gauge mode).
- SS AISI316L body equipped with ceramic diaphragm and ranges from 0-0.1bar up to 0-25bar (gauge or absolute mode).



INSTALLATION
& OPERATING GUIDELINES
FOR MISCELLANEOUS INSTRUMENTS

INSTALLATION GUIDELINES

Pressure measurement - in line

The HF6 transmitter has to be screwed into the bore female $\frac{3}{4}$ " threaded offered by a saddle or other fitting mounted on the pipeline where you want to monitor the pressure. In order to gain a proper watertight connection, use a PTFE sealant tape. The transmitter has to be connected to our M9.10 or directly to a PLC.

Level measurement - screw-in

It is the typical installation for level monitoring in a tank. The HF6 transmitter has to be screwed into the threaded bore offered by a fitting or, better, by a valve mounted on the side of your tank next to the bottom. We advise to avoid the mounting on the bottom with diaphragm upward since the solids could cover or damage it modifying the measurement. The valve can intercept liquid easily during maintenance. In order to gain a proper watertight connection, use a PTFE sealant tape. The transmitter has to be connected to our M9.10 or directly to a PLC.

Level measurement - submersible

Submersible installation can be performed in two ways: cable in contact or cable in conduit.

The transmitter has to be lowered via the cable into the media until you either reach the bottom of your tank, reservoir or underground resource, or until you have reached your desired zero level. Cable has to run from the tank or basin to your control system and has to be connected to our M9.10 or directly to a PLC.

If the cable is in contact, be careful that cable material is compatible fully with measured liquid considering also the temperature. To prevent any mechanical damaging of the cable, we advise you to use a cable-clamp to fix the cable at the top of the tank or along the way.

If cable run in the conduit, use a fitting which can be coupled with the thread on the top of the transmitter (R $\frac{1}{2}$ "). Use a PTFE sealant tape to get a proper watertight connection. Be careful that damp does not spread down the vent capillary to the rear of the diaphragm because the sensor may be damaged.

OPERATING GUIDELINES

Storage

The HF6 level and pressure transmitter should remain in its original packing before installation in order to be protected from damages could occur by external influences.

The permissible temperature range is given in the appropriate data sheet. The transmitter should be protected against dust and humidity.

Maintenance

In general, the hydrostatic level pressure transmitter are maintenance free. According to applications where measured solution can crystallize or can release solids, it could be necessary to clean the diaphragm with water or with a chemical compatible solution avoiding always to stress it physically.



INSTALLATION FITTINGS
**FOR FLOW SENSORS
AND ANALYTICAL ELECTRODES**



STANDARD INSERTION INSTALLATION

INSTALLATION ON PVC PIPES

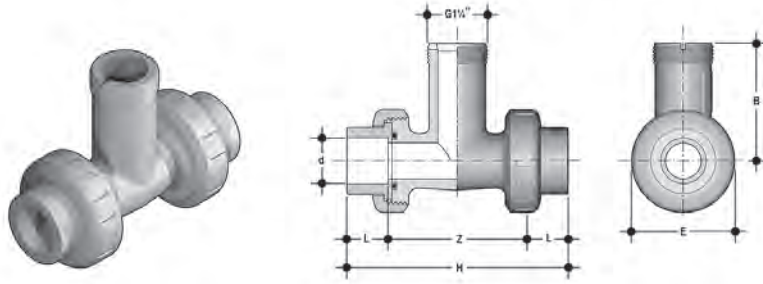

ISO Metric PVC Tee Fittings (female ends for solvent welding - PN10)

Part No.	DN/Size	d/R	O-ring	Body	H	Z	L	B	E	Flow Sensor Length	Suitable for (*)
TFIV20B	15	20	EPDM	U-PVC	113	81	16	73	53	L0	F & A
TFIV25B	20	25	EPDM	U-PVC	126	88	19	8	62	L0	F & A
TFIV32B	25	32	EPDM	U-PVC	139.5	95.5	22	81	71	L0	F & A
TFIV40B	32	40	EPDM	U-PVC	170	118	26	84	84	L0	F & A
TFIV50B	40	50	EPDM	U-PVC	199	137	31	82.5	98	L0	F & A
TFIV20D	15	20	FPM	U-PVC	113	81	16	73	53	L0	F & A
TFIV25D	20	25	FPM	U-PVC	126	88	19	8	62	L0	F & A
TFIV32D	25	32	FPM	U-PVC	139.5	95.5	22	81	71	L0	F & A
TFIV40D	32	40	FPM	U-PVC	170	118	26	84	84	L0	F & A
TFIV50D	40	50	FPM	U-PVC	199	137	31	82.5	98	L0	F & A

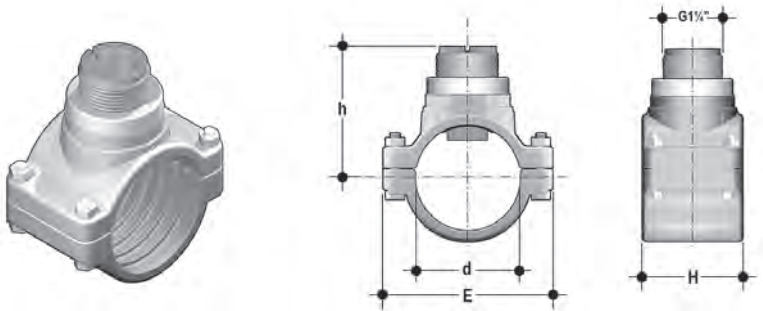

ISO Metric Clamp Saddles (PN10 excluding SMIC serie)

Part No.	DN/Size	d/R	O-ring	Body	Insert	H	E	h	Drilling Hole	Flow Sensor Length	Suitable for (*)
SVIC063BVC	50	63	EPDM	U-PVC	C-PVC	105	116	86.7	35	L0	F & A
SVIC075BVC	65	75	EPDM	U-PVC	C-PVC	105	134	90.8	35	L0	F & A
SVIC090BVC	80	90	EPDM	U-PVC	C-PVC	105	152	95.9	40	L0	F & A
SVIC110BVC	100	110	EPDM	U-PVC	C-PVC	105	176	102.8	40	L0	F & A
SVIC125BVC	110	125	EPDM	U-PVC	C-PVC	112	190	137.9	40	L1	F
SVIC140BVC	125	140	EPDM	U-PVC	C-PVC	114	214	143.1	40	L1	F
SVIC160BVC	150	160	EPDM	U-PVC	C-PVC	120	238	149.9	40	L1	F
SVIC200BVC	180	200	EPDM	U-PVC	C-PVC	133	300	163.7	40	L1	F
SVIC225BVC	200	225	EPDM	U-PVC	C-PVC	125	333	172.3	40	L1	F
SVIC063DVC	50	63	FPM	U-PVC	C-PVC	105	116	86.7	35	L0	F & A
SVIC075DVC	65	75	FPM	U-PVC	C-PVC	105	134	90.8	35	L0	F & A
SVIC090DVC	80	90	FPM	U-PVC	C-PVC	105	152	95.9	40	L0	F & A
SVIC110DVC	100	110	FPM	U-PVC	C-PVC	105	176	102.8	40	L0	F & A
SMIC250IVC*	225	250	EPDM	PP	U-PVC	79	324	203.5	40	L0	F
SMIC280IVC*	250	280	EPDM	PP	U-PVC	88	385	212.2	40	L1	F
SMIC315IVC*	280	315	EPDM	PP	U-PVC	88	385	220.1	40	L1	F

* For IP68 sensors or compact monitors only (PMA 4bar)

(*) Suitable for: F= Flow sensors; A= Analytical electrodes

INSTALLATION ON PVC PIPES

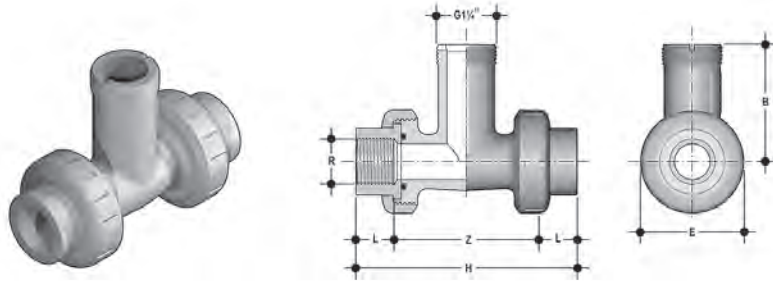

BSP Female Threaded PVC Tee Fittings (parallel threaded female ends - PN10)

Part No.	DN/Size	d/R	O-ring	Body	H	Z	L	B	E	Flow Sensor Length	Suitable for (*)
TFFV20B	15	1/2"	EPDM	U-PVC	118.5	88.5	15	73	53	L0	F & A
TFFV25B	20	3/4"	EPDM	U-PVC	127.5	94.9	16.3	80	62	L0	F & A
TFFV32B	25	1"	EPDM	U-PVC	146	107.8	19.1	81	71	L0	F & A
TFFV40B	32	1 1/4"	EPDM	U-PVC	177	134.2	21.4	84	84	L0	F & A
TFFV50B	40	1 1/2"	EPDM	U-PVC	191	148.2	21.4	82.5	98	L0	F & A
TFFV20D	15	1/2"	FPM	U-PVC	118.5	88.5	15	73	53	L0	F & A
TFFV25D	20	3/4"	FPM	U-PVC	127.5	94.9	16.3	80	62	L0	F & A
TFFV32D	25	1"	FPM	U-PVC	146	107.8	19.1	81	71	L0	F & A
TFFV40D	32	1 1/4"	FPM	U-PVC	177	134.2	21.4	84	84	L0	F & A
TFFV50D	40	1 1/2"	FPM	U-PVC	191	148.2	21.4	82.5	98	L0	F & A

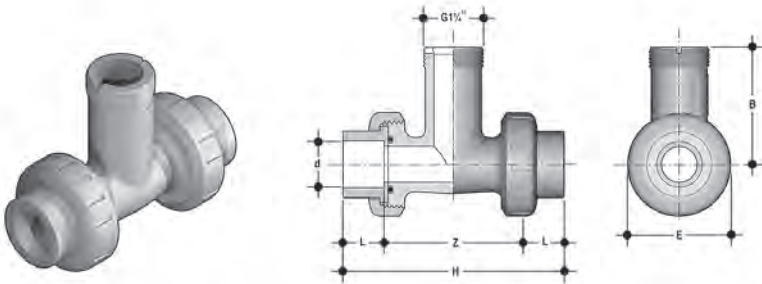

BS Solvent Welding PVC Tee Fittings (female ends for solvent welding - PN10)

Part No.	DN/Size	d/R	O-ring	Body	H	Z	L	B	E	Flow Sensor Length	Suitable for (*)
TFLV20B	15	1/2"	EPDM	U-PVC	113	80	16.5	73	53	L0	F & A
TFLV25B	20	3/4"	EPDM	U-PVC	126	88	19	80	62	L0	F & A
TFLV32B	25	1"	EPDM	U-PVC	139.5	94.5	22.5	81	71	L0	F & A
TFLV40B	32	1 1/4"	EPDM	U-PVC	17	118	26	84	84	L0	F & A
TFLV50B	40	1 1/2"	EPDM	U-PVC	199	139	30	82.5	98	L0	F & A
TFLV20D	15	1/2"	FPM	U-PVC	113	80	16.5	73	53	L0	F & A
TFLV25D	20	3/4"	FPM	U-PVC	126	88	19	80	62	L0	F & A
TFLV32D	25	1"	FPM	U-PVC	139.5	94.5	22.5	81	71	L0	F & A
TFLV40D	32	1 1/4"	FPM	U-PVC	17	118	26	84	84	L0	F & A
TFLV50D	40	1 1/2"	FPM	U-PVC	199	139	30	82.5	98	L0	F & A

(*) Suitable for: F= Flow sensors; A= Analytical electrodes

INSTALLATION ON PVC PIPES

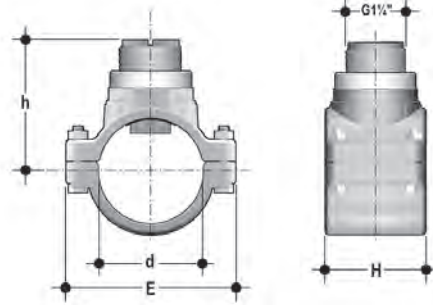

BS Clamp Saddles (PN10)

Part No.	DN/ Size	d/R	O-ring	Body	Insert	H	E	h	Drilling Hole	Flow Sensor Length	Suitable for (*)
SVLC2.0BVM	50	2"	EPDM	U-PVC	C-PVC	105	116	85.3	35	L0	F & A
SVLC3.0BVM	80	3"	EPDM	U-PVC	C-PVC	105	152	95.0	40	L0	F & A
SVLC4.0BVM	100	4"	EPDM	U-PVC	C-PVC	105	176	103.5	40	L0	F & A
SVLC6.0BVM	150	6"	EPDM	U-PVC	C-PVC	120	238	151.7	40	L1	F
SVLC8.0BVM	200	8"	EPDM	U-PVC	C-PVC	125	333	169.8	40	L1	F
SVLC2.0DVM	50	2"	FPM	U-PVC	C-PVC	105	116	85.3	35	L0	F & A
SVLC3.0DVM	80	3"	FPM	U-PVC	C-PVC	105	152	95.0	40	L0	F & A
SVLC4.0DVM	100	4"	FPM	U-PVC	C-PVC	105	176	103.5	40	L0	F & A

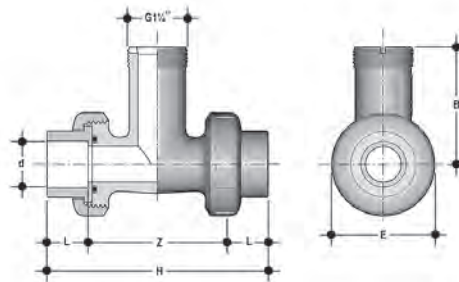

ASTM SCH. 80 PVC Tee Fittings (female ends for solvent welding - PN10)

Part No.	DN/ Size	d/R	O-ring	Body	H	Z	L	B	E	Flow Sensor Length	Suitable for (*)
TFAV20B	15	1/2"	EPDM	U-PVC	4.92"	3.15"	0.89"	2.87"	2.09"	L0	F & A
TFAV25B	20	3/4"	EPDM	U-PVC	5.51"	3.50"	1.00"	3.15"	2.44"	L0	F & A
TFAV32B	25	1"	EPDM	U-PVC	6.04"	3.78"	1.13"	3.19"	2.80"	L0	F & A
TFAV40B	32	1 1/4"	EPDM	U-PVC	7.34"	4.80"	1.26"	3.31"	3.31"	L0	F & A
TFAV50B	40	1 1/2"	EPDM	U-PVC	8.15"	5.39"	1.38"	3.25"	3.86"	L0	F & A
TFAV20D	15	1/2"	FPM	U-PVC	4.92"	3.15"	0.89"	2.87"	2.09"	L0	F & A
TFAV25D	20	3/4"	FPM	U-PVC	5.51"	3.50"	1.00"	3.15"	2.44"	L0	F & A
TFAV32D	25	1"	FPM	U-PVC	6.04"	3.78"	1.13"	3.19"	2.80"	L0	F & A
TFAV40D	32	1 1/4"	FPM	U-PVC	7.34"	4.80"	1.26"	3.31"	3.31"	L0	F & A
TFAV50D	40	1 1/2"	FPM	U-PVC	8.15"	5.39"	1.38"	3.25"	3.86"	L0	F & A

(*) Suitable for: F= Flow sensors; A= Analytical electrodes

INSTALLATION ON PVC PIPES

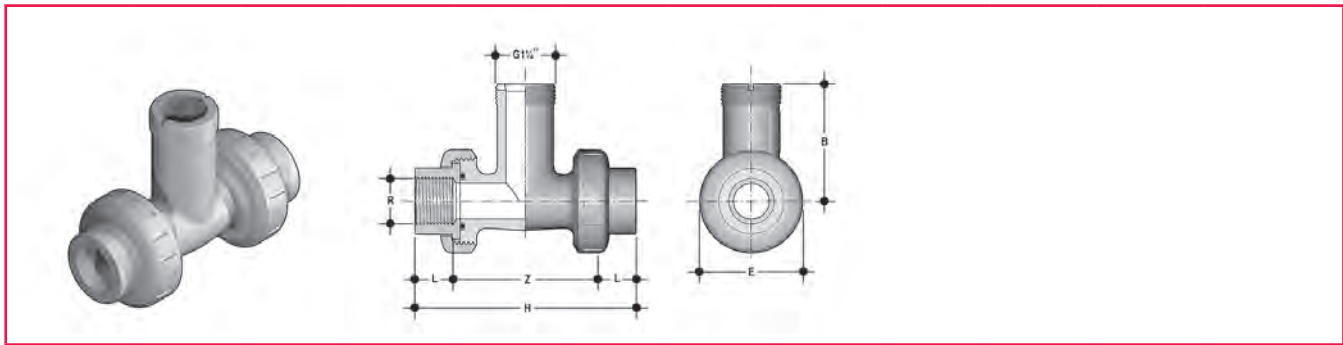

NPT Female Threaded PVC Tee Fittings (NPT threaded female ends - PN10)

Part No.	DN/Size	d/R	O-ring	Body	H	Z	L	B	E	Flow Sensor Length	Suitable for (*)
TFNV20B	15	1/2"	EPDM	U-PVC	4.67"	3.26"	0.70"	2.87"	2.09"	L0	F & A
TFNV25B	20	3/4"	EPDM	U-PVC	5.02"	3.60"	0.71"	3.15"	2.44"	L0	F & A
TFNV32B	25	1"	EPDM	U-PVC	5.75"	3.97"	0.89"	3.19"	2.80"	L0	F & A
TFNV40B	32	1 1/4"	EPDM	U-PVC	6.97"	5.12"	0.93"	3.31"	3.31"	L0	F & A
TFNV50B	40	1 1/2"	EPDM	U-PVC	7.52"	5.28"	1.12"	3.25"	3.86"	L0	F & A
TFNV20D	15	1/2"	FPM	U-PVC	4.67"	3.26"	0.70"	2.87"	2.09"	L0	F & A
TFNV25D	20	3/4"	FPM	U-PVC	5.02"	3.60"	0.71"	3.15"	2.44"	L0	F & A
TFNV32D	25	1"	FPM	U-PVC	5.75"	3.97"	0.89"	3.19"	2.80"	L0	F & A
TFNV40D	32	1 1/4"	FPM	U-PVC	6.97"	5.12"	0.93"	3.31"	3.31"	L0	F & A
TFNV50D	40	1 1/2"	FPM	U-PVC	7.52"	5.28"	1.12"	3.25"	3.86"	L0	F & A

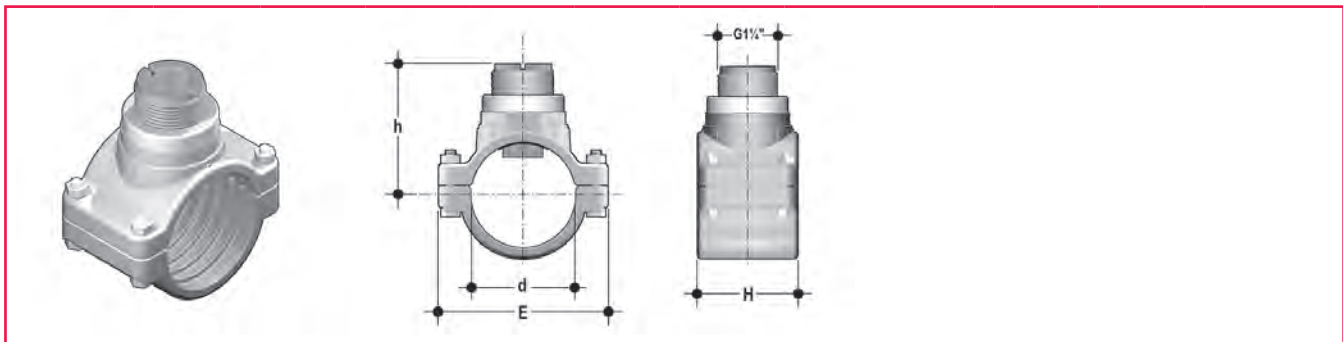

ASTM Clamp Saddles (PN10)

Part No.	DN/Size	d/R	O-ring	Body	Insert	H	E	h	Drilling Hole	Flow Sensor Length	Suitable for (*)
SVAC2.0BVM	50	2"	EPDM	U-PVC	C-PVC	4.13"	4.57"	3.3"	1.38"	L0	F & A
SVAC2.5BVM	65	2 1/2"	EPDM	U-PVC	C-PVC	4.13"	5.28"	3.4"	1.38"	L0	F & A
SVAC3.0BVM	80	3"	EPDM	U-PVC	C-PVC	4.13"	5.98"	3.6"	1.57"	L0	F & A
SVAC4.0BVM	100	4"	EPDM	U-PVC	C-PVC	4.13"	6.93"	4.0"	1.57"	L0	F & A
SVAC5.0BVM	125	5"	EPDM	U-PVC	C-PVC	4.49"	8.43"	5.6"	1.57"	L1	F
SVAC6.0BVM	150	6"	EPDM	U-PVC	C-PVC	4.72"	9.37"	5.9"	1.57"	L1	F
SVAC8.0BVM	200	8"	EPDM	U-PVC	C-PVC	4.92"	13.11"	6.6"	1.57"	L1	F
SVAC2.0DVM	50	2"	FPM	U-PVC	C-PVC	4.13"	4.57"	3.3"	1.38"	L0	F & A
SVAC2.5DVM	65	2 1/2"	FPM	U-PVC	C-PVC	4.13"	5.28"	3.4"	1.38"	L0	F & A
SVAC3.0DVM	80	3"	FPM	U-PVC	C-PVC	4.13"	5.98"	3.6"	1.57"	L0	F & A
SVAC4.0DVM	100	4"	FPM	U-PVC	C-PVC	4.13"	6.93"	4.0"	1.57"	L0	F & A

(*) Suitable for: F= Flow sensors; A= Analytical electrodes

INSTALLATION ON C-PVC PIPES

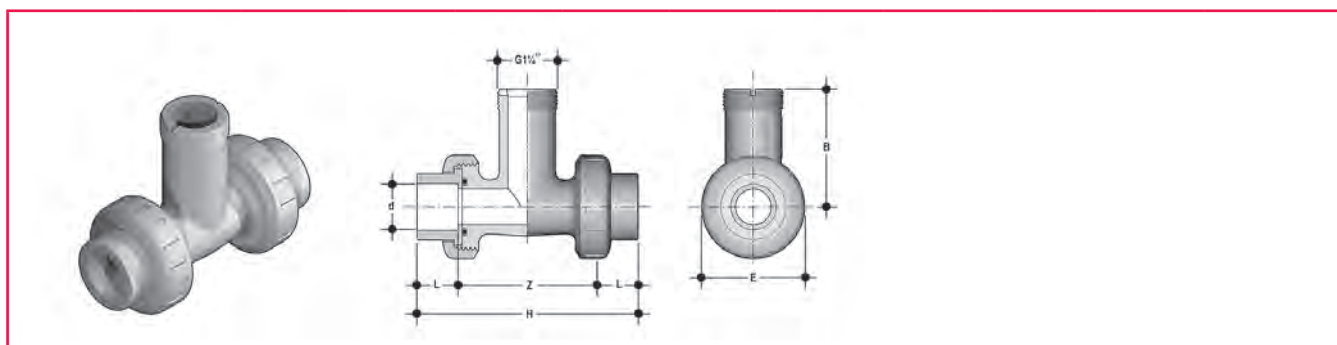

ISO Metric PVDF Tee Fittings (C-PVC end connectors for solvent welding - PN10)

Part No.	DN/ Size	d/R	O-ring	Body	H	Z	L	B	E	Flow Sensor Length	Suitable for (*)
TFIF20BC	15	20	EPDM	PVDF	112	80	16	73	53	L0	F & A
TFIF25BC	20	25	EPDM	PVDF	125	87	19	77	64	L0	F & A
TFIF32BC	25	32	EPDM	PVDF	139	95	22	81	72	L0	F & A
TFIF40BC	32	40	EPDM	PVDF	167	115	26	84	84	L0	F & A
TFIF50BC	40	50	EPDM	PVDF	196	134	31	82.5	97	L0	F & A
TFIF20DC	15	20	FPM	PVDF	112	80	16	73	53	L0	F & A
TFIF25DC	20	25	FPM	PVDF	125	87	19	77	64	L0	F & A
TFIF32DC	25	32	FPM	PVDF	139	95	22	81	72	L0	F & A
TFIF40DC	32	40	FPM	PVDF	167	115	26	84	84	L0	F & A
TFIF50DC	40	50	FPM	PVDF	196	134	31	82.5	97	L0	F & A

(*) Suitable for: F= Flow sensors; A= Analytical electrodes

INSTALLATION ON C-PVC PIPES

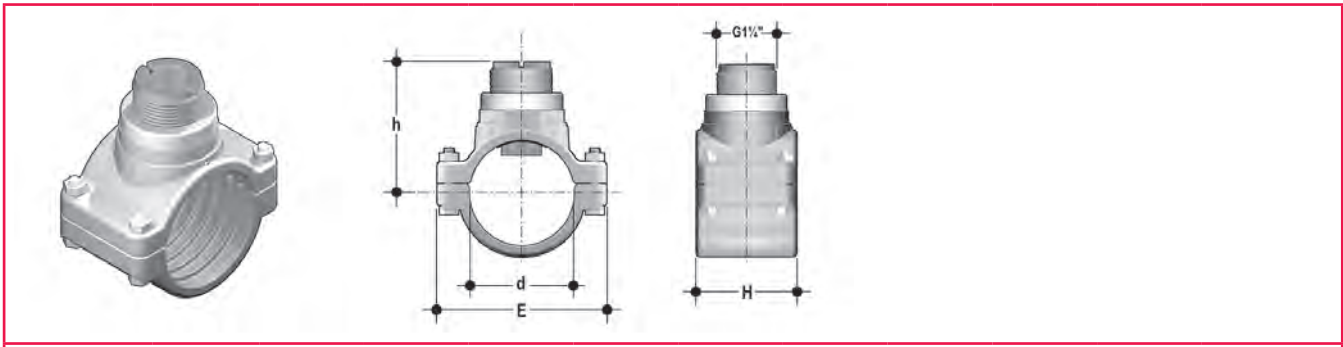

ISO Metric Clamp Saddles (PN10 excluding SMIC serie)

Part No.	DN/ Size	d/R	O-ring	Body	Insert	H	E	h	Drilling Hole	Flow Sensor Lenght	Suitable for (*)
SVIC063BVC	50	63	EPDM	U-PVC	C-PVC	105	116	86.7	35	L0	F & A
SVIC075BVC	65	75	EPDM	U-PVC	C-PVC	105	134	90.8	35	L0	F & A
SVIC090BVC	80	90	EPDM	U-PVC	C-PVC	105	152	95.9	40	L0	F & A
SVIC110BVC	100	110	EPDM	U-PVC	C-PVC	105	176	102.8	40	L0	F & A
SVIC125BVC	110	125	EPDM	U-PVC	C-PVC	112	190	137.9	40	L1	F
SVIC140BVC	125	140	EPDM	U-PVC	C-PVC	114	214	143.1	40	L1	F
SVIC160BVC	150	160	EPDM	U-PVC	C-PVC	120	238	149.9	40	L1	F
SVIC200BVC	180	200	EPDM	U-PVC	C-PVC	133	300	163.7	40	L1	F
SVIC225BVC	200	225	EPDM	U-PVC	C-PVC	125	333	172.3	40	L1	F
SVIC063DVC	50	63	FPM	U-PVC	C-PVC	105	116	86.7	35	L0	F & A
SVIC075DVC	65	75	FPM	U-PVC	C-PVC	105	134	90.8	35	L0	F & A
SVIC090DVC	80	90	FPM	U-PVC	C-PVC	105	152	95.9	40	L0	F & A
SVIC110DVC	100	110	FPM	U-PVC	C-PVC	105	176	102.8	40	L0	F & A
SMIC250IVC*	225	250	EPDM	PP	U-PVC	79	324	203.5	40	L0	F
SMIC280IVC*	250	280	EPDM	PP	U-PVC	88	385	212.2	40	L1	F
SMIC315IVC*	280	315	EPDM	PP	U-PVC	88	385	220.1	40	L1	F

* For IP68 sensors or compact monitors only (PMA 4bar)

(*) Suitable for: F= Flow sensors; A= Analytical electrodes

INSTALLATION ON PP PIPES

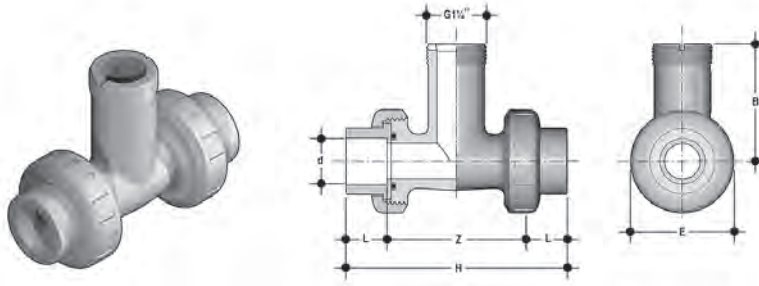

ISO Metric PP Tee Fittings (female ends for socket welding - PN10)

Part No.	DN/ Size	d/R	O-ring	Body	H	Z	L	B	E	Flow Sensor Length	Suitable for (*)
TFIM20B	15	20	EPDM	PP	111	73	14.5	73	53	L0	F & A
TFIM25B	20	25	EPDM	PP	120.5	80	16	80	62	L0	F & A
TFIM32B	25	32	EPDM	PP	133.5	81	18	81	71	L0	F & A
TFIM40B	32	40	EPDM	PP	163.5	84	20.5	84	84	L0	F & A
TFIM50B	40	50	EPDM	PP	195	82.5	23.5	82.5	98	L0	F & A
TFIM20D	15	20	FPM	PP	111	73	14.5	73	53	L0	F & A
TFIM25D	20	25	FPM	PP	120.5	80	16	80	62	L0	F & A
TFIM32D	25	32	FPM	PP	133.5	81	18	81	71	L0	F & A
TFIM40D	32	40	FPM	PP	163.5	84	20.5	84	84	L0	F & A
TFIM50D	40	50	FPM	PP	195	82.5	23.5	82.5	98	L0	F & A

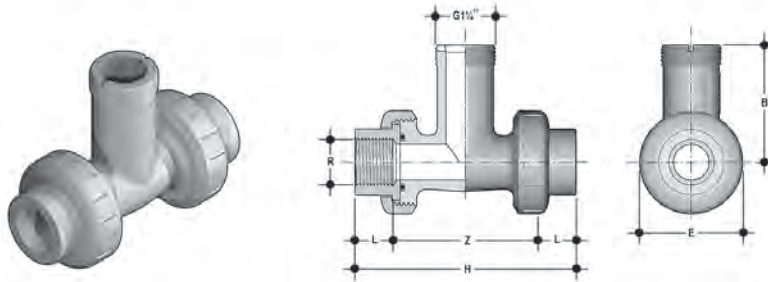

BSP Female Threaded PP Tee Fittings (parallel threaded female ends - PN10)

Part No.	DN/ Size	d/R	O-ring	Body	H	Z	L	B	E	Flow Sensor Length	Suitable for (*)
TFFM20B	15	1/2"	EPDM	PP	113	83	15	73	53	L0	F & A
TFFM25B	20	3/4"	EPDM	PP	126	93.4	16.3	80	62	L0	F & A
TFFM32B	25	1"	EPDM	PP	139.5	101.3	19.1	81	71	L0	F & A
TFFM40B	32	1 1/4"	EPDM	PP	17	127.2	21.4	84	84	L0	F & A
TFFM50B	40	1 1/2"	EPDM	PP	199	156.2	21.4	82.5	98	L0	F & A
TFFM20D	15	1/2"	FPM	PP	113	83	15	73	53	L0	F & A
TFFM25D	20	3/4"	FPM	PP	126	93.4	16.3	80	62	L0	F & A
TFFM32D	25	1"	FPM	PP	139.5	101.3	19.1	81	71	L0	F & A
TFFM40D	32	1 1/4"	FPM	PP	17	127.2	21.4	84	84	L0	F & A
TFFM50D	40	1 1/2"	FPM	PP	199	156.2	21.4	82.5	98	L0	F & A

(*) Suitable for: F= Flow sensors; A= Analytical electrodes

INSTALLATION ON PP PIPES

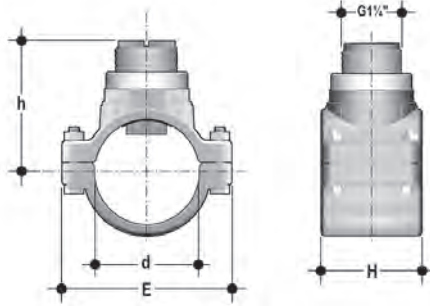

ISO metric Clamp Saddles (PN10 excluding SMIC serie)

Part No.	DN/Size	d/R	O-ring	Body	Insert	H	E	h	Drilling Hole	Flow Sensor Length	Suitable for (*)
SVIC063BME	50	63	EPDM	U-PVC	C-PVC **	105	116	84.3	35	L0	F & A
SVIC075BME	65	75	EPDM	U-PVC	C-PVC **	105	134	88.	35	L0	F & A
SVIC090BME	80	90	EPDM	U-PVC	C-PVC **	105	152	92.6	4	L0	F & A
SVIC110BME	100	110	EPDM	U-PVC	C-PVC **	105	176	98.8	40	L0	F & A
SVIC125BME	110	125	EPDM	U-PVC	C-PVC **	112	190	133.3	40	L1	F
SVIC140BME	125	140	EPDM	U-PVC	C-PVC **	114	214	138.0	40	L1	F
SVIC160BME	150	160	EPDM	U-PVC	C-PVC **	120	238	144.1	40	L1	F
SVIC200BME	180	200	EPDM	U-PVC	C-PVC **	133	300	156.4	40	L1	F
SVIC225BME	200	225	EPDM	U-PVC	C-PVC **	125	333	164.1	40	L1	F
SVIC063DME	50	63	FPM	U-PVC	C-PVC **	105	116	84.3	35	L0	F & A
SVIC075DME	65	75	FPM	U-PVC	C-PVC **	105	134	88.	35	L0	F & A
SVIC090DME	80	90	FPM	U-PVC	C-PVC **	105	152	92.6	4	L0	F & A
SVIC110DME	100	110	FPM	U-PVC	C-PVC **	105	176	98.8	40	L0	F & A
SMIC250IME*	225	250	EPDM	PP	U-PVC **	79	324	189.9	40	L0	F
SMIC280IME*	250	280	EPDM	PP	U-PVC **	88	385	200.2	40	L1	F
SMIC315IME*	300	315	EPDM	PP	U-PVC **	88	385	209.3	40	L1	F

* For IP68 sensors or compact monitors only (PMA 4bar) ** PVDF insert available on request

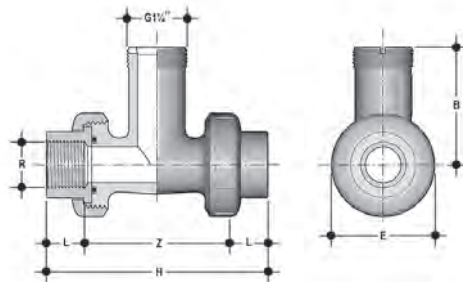

NPT Female Threaded PP Tee Fittings (NPT threaded female ends - PN10)

Part No.	DN/Size	d/R	O-ring	Body	H	Z	L	B	E	Flow Sensor Length	Suitable for (*)
TFNM20B	15	1/2"	EPDM	PP	4.45"	3.05"	0.70"	2.87"	2.09"	L0	F & A
TFNM25B	20	3/4"	EPDM	PP	4.96"	3.54"	0.71"	3.15"	2.44"	L0	F & A
TFNM32B	25	1"	EPDM	PP	5.49"	3.71"	0.89"	3.19"	2.80"	L0	F & A
TFNM40B	32	1 1/4"	EPDM	PP	6.69"	4.84"	0.93"	3.31"	3.31"	L0	F & A
TFNM50B	40	1 1/2"	EPDM	PP	7.83"	5.59"	1.12"	3.25"	3.86"	L0	F & A
TFNM20D	15	1/2"	FPM	PP	4.45"	3.05"	0.70"	2.87"	2.09"	L0	F & A
TFNM25D	20	3/4"	FPM	PP	4.96"	3.54"	0.71"	3.15"	2.44"	L0	F & A
TFNM32D	25	1"	FPM	PP	5.49"	3.71"	0.89"	3.19"	2.80"	L0	F & A
TFNM40D	32	1 1/4"	FPM	PP	6.69"	4.84"	0.93"	3.31"	3.31"	L0	F & A
TFNM50D	40	1 1/2"	FPM	PP	7.83"	5.59"	1.12"	3.25"	3.86"	L0	F & A

(*) Suitable for: F= Flow sensors; A= Analytical electrodes

INSTALLATION ON PP PIPES

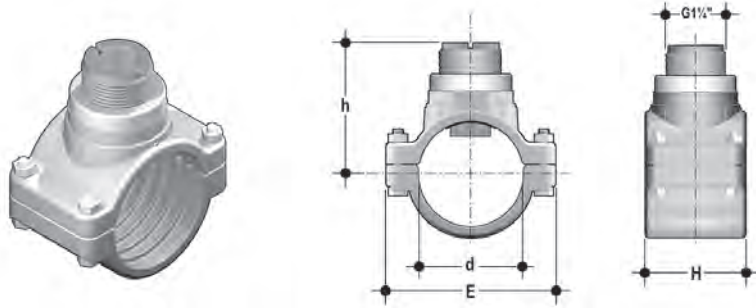

ASTM Clamp Saddles (PN10)

Part No.	DN/Size	d/R	O-ring	Body	Insert	H	E	h	Drilling Hole	Flow Sensor Length	Suitable for (*)
SVAC2.0BVM	50	2"	EPDM	U-PVC	C-PVC**	4.13"	4.57"	3.29"	1.38"	L0	F & A
SVAC2.5BVM	65	2 1/2"	EPDM	U-PVC	C-PVC**	4.13"	5.28"	3.43"	1.38"	L0	F & A
SVAC3.0BVM	80	3"	EPDM	U-PVC	C-PVC**	4.13"	5.98"	3.65"	1.57"	L0	F & A
SVAC4.0BVM	100	4"	EPDM	U-PVC	C-PVC**	4.13"	6.93"	4.00"	1.57"	L0	F & A
SVAC5.0BVM	125	5"	EPDM	U-PVC	C-PVC**	4.49"	8.43"	5.55"	1.57"	L1	F
SVAC6.0BVM	150	6"	EPDM	U-PVC	C-PVC**	4.72"	9.37"	5.91"	1.57"	L1	F
SVAC8.0BVM	200	8"	EPDM	U-PVC	C-PVC**	4.92"	13.11"	6.61"	1.57"	L1	F
SVAC2.0DVM	50	2"	FPM	U-PVC	C-PVC**	4.13"	4.57"	3.29"	1.38"	L0	F & A
SVAC2.5DVM	65	2 1/2"	FPM	U-PVC	C-PVC**	4.13"	5.28"	3.43"	1.38"	L0	F & A
SVAC3.0DVM	80	3"	FPM	U-PVC	C-PVC**	4.13"	5.98"	3.65"	1.57"	L0	F & A
SVAC4.0DVM	100	4"	FPM	U-PVC	C-PVC**	4.13"	6.93"	4.00"	1.57"	L0	F & A

** PVDF insert available on request

(*) Suitable for: F= Flow sensors; A= Analytical electrodes

INSTALLATION ON PVDF PIPES

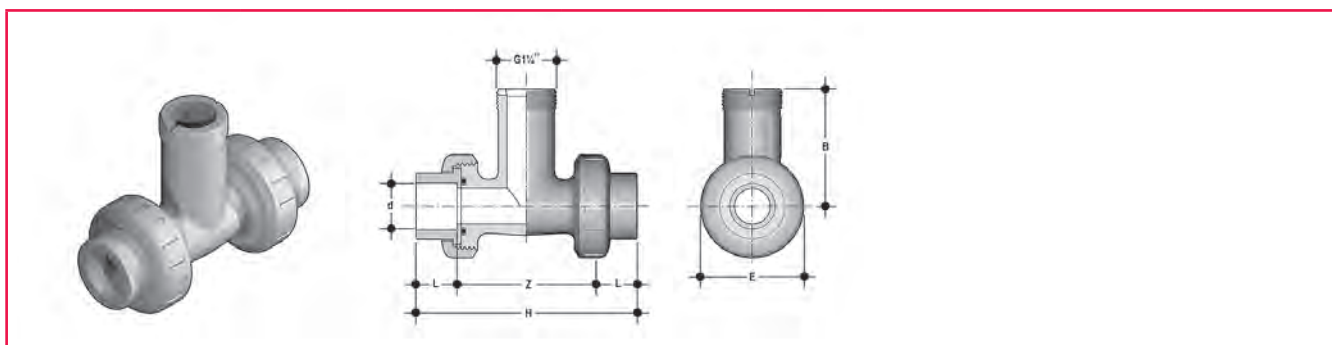

ISO Metric PVDF Tee Fittings (female ends tor socket welding - PN10)

Part No.	DN/ Size	d/R	O-ring	Body	H	Z	L	B	E	Flow Sensor Length	Suitable for (*)
TFIF20B	15	20	EPDM	PVDF	111	80	14.5	73	53	L0	F & A
TFIF25B	20	25	EPDM	PVDF	120.5	87	16	80	62	L0	F & A
TFIF32B	25	32	EPDM	PVDF	133.5	95	18	81	71	L0	F & A
TFIF40B	32	40	EPDM	PVDF	161.5	115	20.5	84	84	L0	F & A
TFIF50B	40	50	EPDM	PVDF	193.5	134	23.5	82.5	98	L0	F & A
TFIF20D	15	20	FPM	PVDF	111	80	14.5	73	53	L0	F & A
TFIF25D	20	25	FPM	PVDF	120.5	87	16	80	62	L0	F & A
TFIF32D	25	32	FPM	PVDF	133.5	95	18	81	71	L0	F & A
TFIF40D	32	40	FPM	PVDF	161.5	115	20.5	84	84	L0	F & A
TFIF50D	40	50	FPM	PVDF	193.5	134	23.5	82.5	98	L0	F & A

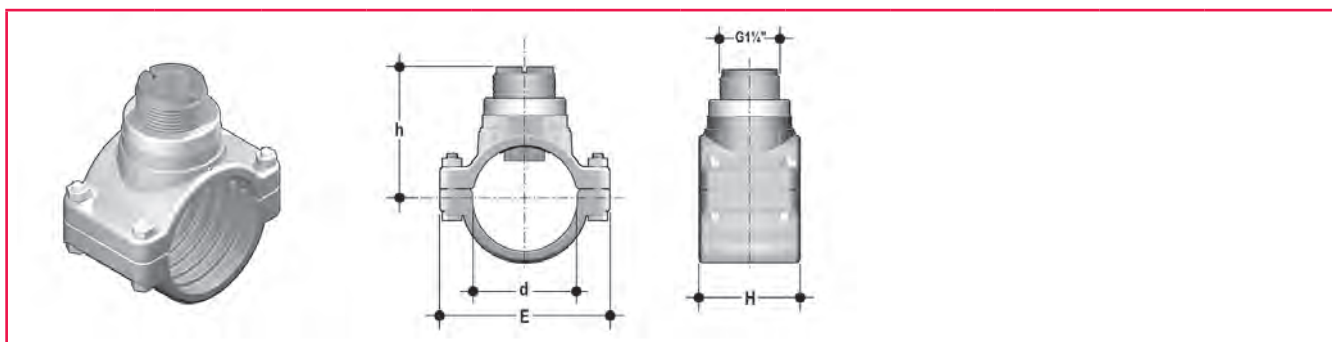

ISO Metric Clamp Saddles (PN10)

Part No.	DN/ Size	d/R	O-ring	Body	Insert	H	E	h	Drilling Hole	Flow Sensor Length	Suitable for (*)
SVIF063BF	50	63	EPDM	U-PVC	PVDF	105	116	87.2	35	L0	F & A
SVIF075BF	65	75	EPDM	U-PVC	PVDF	105	134	91.5	35	L0	F & A
SVIF090BF	80	90	EPDM	U-PVC	PVDF	105	152	96.8	40	L0	F & A
SVIF110BF	100	110	EPDM	U-PVC	PVDF	105	176	104.0	40	L0	F & A
SVIF063DF	50	63	FPM	U-PVC	PVDF	105	116	87.2	35	L0	F & A
SVIF075DF	65	75	FPM	U-PVC	PVDF	105	134	91.5	35	L0	F & A
SVIF090DF	80	90	FPM	U-PVC	PVDF	105	152	96.8	40	L0	F & A
SVIF110DF	100	110	FPM	U-PVC	PVDF	105	176	104.0	40	L0	F & A

(*) Suitable for: F= Flow sensors; A= Analytical electrodes

INSTALLATION ON PE PIPES

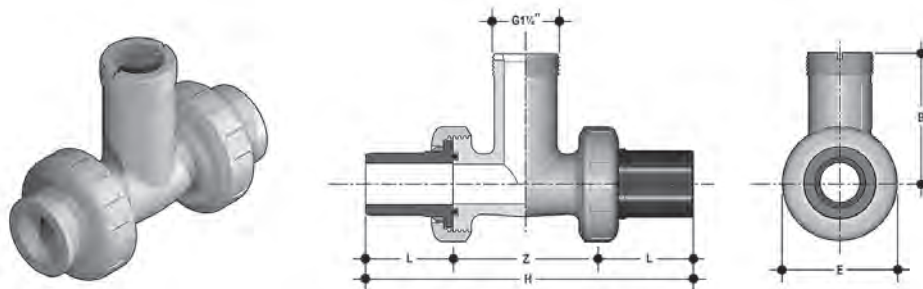

ISO Metric PVC Tee Fittings (PE end connectors for electrofusion or butt welding - PN10)

Part No.	DN/Size	d/R	O-ring	Body	H	Z	L	B	E	Flow Sensor Length	Suitable for (*)
TFIV20BE	15	20	EPDM	U-PVC	183	73	55	73	53	L0	F & A
TFIV25BE	20	25	EPDM	U-PVC	223	83	70	80	62	L0	F & A
TFIV32BE	25	32	EPDM	U-PVC	237	89	74	81	71	L0	F & A
TFIV40BE	32	40	EPDM	U-PVC	266	110	78	84	84	L0	F & A
TFIV50BE	40	50	EPDM	U-PVC	295	127	84	82.5	98	L0	F & A
TFIV20DE	15	20	FPM	U-PVC	183	73	55	73	53	L0	F & A
TFIV25DE	20	25	FPM	U-PVC	223	83	70	80	62	L0	F & A
TFIV32DE	25	32	FPM	U-PVC	237	89	74	81	71	L0	F & A
TFIV40DE	32	40	FPM	U-PVC	266	110	78	84	84	L0	F & A
TFIV50DE	40	50	FPM	U-PVC	295	127	84	82.5	98	L0	F & A

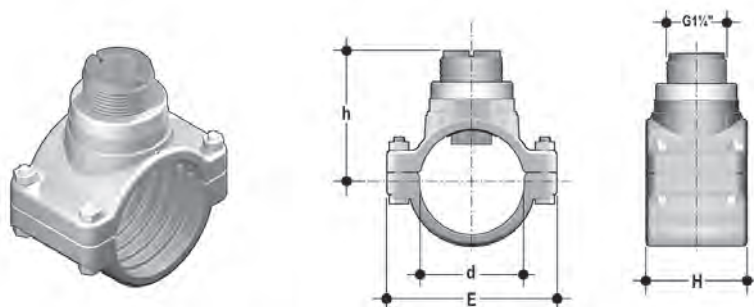

ISO Metric Clamp Saddles (PN10 excluding SMIC serie)

Part No.	DN/Size	d/R	O-ring	Body	Insert	H	E	h	Drilling Hole	Flow Sensor Length	Suitable for (*)
SVIC063BME	50	63	EPDM	U-PVC	C-PVC	105	116	84.3	35	L0	F & A
SVIC075BME	65	75	EPDM	U-PVC	C-PVC	105	134	88.	35	L0	F & A
SVIC090BME	80	90	EPDM	U-PVC	C-PVC	105	152	92.6	4	L0	F & A
SVIC110BME	100	110	EPDM	U-PVC	C-PVC	105	176	98.8	40	L0	F & A
SVIC125BME	110	125	EPDM	U-PVC	C-PVC	112	190	133.3	40	L1	F
SVIC140BME	125	140	EPDM	U-PVC	C-PVC	114	214	138.0	40	L1	F
SVIC160BME	150	160	EPDM	U-PVC	C-PVC	120	238	144.1	40	L1	F
SVIC200BME	180	200	EPDM	U-PVC	C-PVC	133	300	156.4	40	L1	F
SVIC225BME	200	225	EPDM	U-PVC	C-PVC	125	333	164.1	40	L1	F
SVIC063DME	50	63	FPM	U-PVC	C-PVC	105	116	84.3	35	L0	F & A
SVIC075DME	65	75	FPM	U-PVC	C-PVC	105	134	88.	35	L0	F & A
SVIC090DME	80	90	FPM	U-PVC	C-PVC	105	152	92.6	4	L0	F & A
SVIC110DME	100	110	FPM	U-PVC	C-PVC	105	176	98.8	40	L0	F & A
SMIC250IME*	225	250	EPDM	PP	U-PVC	79	324	189.9	40	L0	F
SMIC280IME*	250	280	EPDM	PP	U-PVC	88	385	200.2	40	L1	F
SMIC315IME*	300	315	EPDM	PP	U-PVC	88	385	209.3	40	L1	F

* For IP68 sensors or compact monitors only (PMA 4bar)

(*) Suitable for: F= Flow sensors; A= Analytical electrodes

INSTALLATION ON METAL PIPES

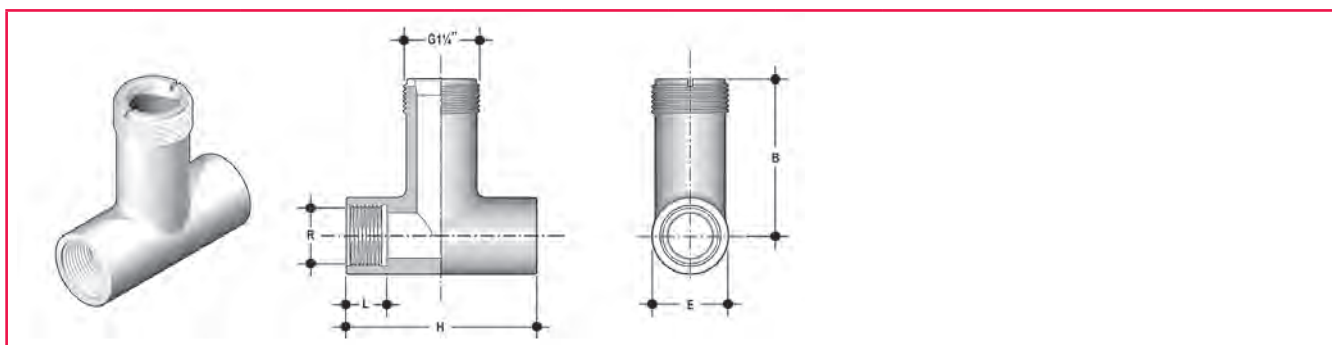

BSP Female Threaded 316 SS Tee Fittings (PN25)

Part No.	DN/Size	d/R	O-ring	Body	H	Z	L	B	E	Flow Sensor Length	Suitable for (*)
TFFX20	15	1/2"	-	316 SS	85	-	16	73	42	L0	F & A
TFFX25	20	3/4"	-	316 SS	95	-	20	81.2	42	L0	F & A
TFFX32	25	1"	-	316 SS	105	-	22.5	81.2	42	L0	F & A
TFFX40	32	1 1/4"	-	316 SS	12	-	20.5	83.8	54	L0	F & A



Strap-on Saddles (PN16)

Part No.	DN/Size	O.D. min.	O.D. max	Parallel Thread (GAS)	O-ring	Body	Insert	h	Drilling Hole	Flow Sensor Length	Suitable for (*)
SZIC080I*	80	88	104	1 1/4"	EPDM	Cast iron + SS	C-PVC	153	40	L0	F
SZIC100I*	100	112	126	1 1/4"	EPDM	Cast iron + SS	C-PVC	160	40	L0	F
SZIC125I*	125	140	154	1 1/4"	EPDM	Cast iron + SS	C-PVC	170	40	L0	F
SZIC150I*	150	168	184	1 1/4"	EPDM	Cast iron + SS	C-PVC	180	40	L0	F
SZIC200I*	200	218	234	1 1/4"	EPDM	Cast iron + SS	C-PVC	228	40	L1	F
SZIC250I*	250	272	286	1 1/4"	EPDM	Cast iron + SS	C-PVC	247	40	L1	F
SZIC300I*	300	322	344	1 1/4"	EPDM	Cast iron + SS	C-PVC	266	40	L1	F
SZIC350I*	350	356	384	1 1/4"	EPDM	Cast iron + SS	C-PVC	305	40	L1	F
SZIC400I*	400	425	458	1 1/4"	EPDM	Cast iron + SS	C-PVC	324	40	L1	F
SZIC450I*	450	475	516	1 1/4"	EPDM	Cast iron + SS	C-PVC	343	40	L1	F

(*) For IP68 sensors or compact monitors only

(*) Suitable for: F= Flow sensors; A= Analytical electrodes

INSTALLATION ON METAL PIPES

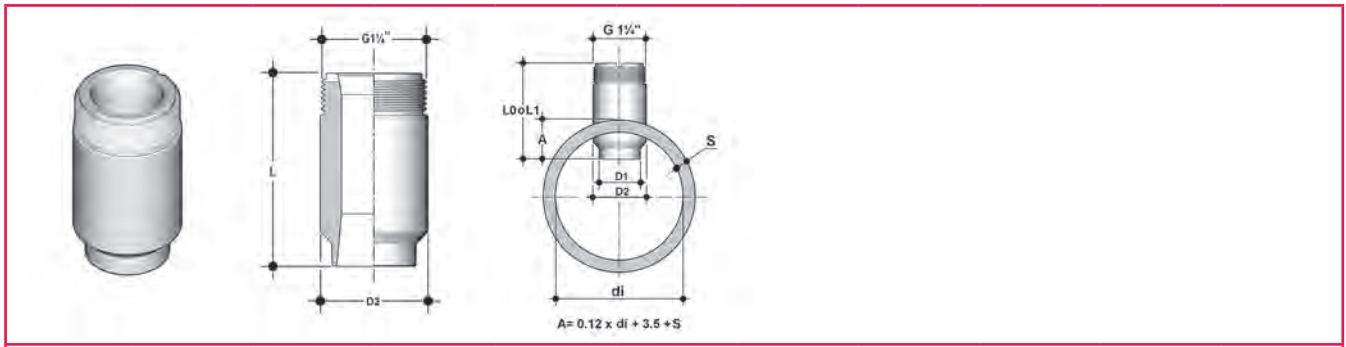

316L SS Weld on Adapters (PN25)

Part No.	DN/Size	d/R	Parallel Thread (GAS)	Body	L	D1	D2	Drilling Hole	Flow Sensor Length	Suitable for (*)
WAIXL0	40	-	1 1/4"	316L SS	68.5	33,9	34	34	L0	F & A
WAIXL0	50	-	1 1/4"	316L SS	68.5	33,9	44	44	L0	F & A
WAIXL0	60	-	1 1/4"	316L SS	68.5	33,9	44	44	L0	F & A
WAIXL0	65	-	1 1/4"	316L SS	68.5	33,9	44	44	L0	F & A
WAIXL0	80	-	1 1/4"	316L SS	68.5	33,9	44	44	L0	F & A
WAIXL0	100	-	1 1/4"	316L SS	68.5	33,9	44	44	L0	F & A
WAIXL0	110	-	1 1/4"	316L SS	68.5	33,9	44	44	L0	F & A
WAIXL0	125	-	1 1/4"	316L SS	68.5	33,9	44	44	L0	F
WAIXL0	150	-	1 1/4"	316L SS	68.5	33,9	44	44	L0	F
WAIXL0	175	-	1 1/4"	316L SS	68.5	33,9	44	44	L0	F
WAIXL0	200	-	1 1/4"	316L SS	68.5	33,9	44	44	L0	F
WAIXL1	225	-	1 1/4"	316L SS	98.5	33,9	44	44	L1	F
WAIXL1	250	-	1 1/4"	316L SS	98.5	33,9	44	44	L1	F
WAIXL1	300	-	1 1/4"	316L SS	98.5	33,9	44	44	L1	F
WAIXL1	350	-	1 1/4"	316L SS	98.5	33,9	44	44	L1	F
WAIXL1	400	-	1 1/4"	316L SS	98.5	33,9	44	44	L1	F
WAIXL1	450	-	1 1/4"	316L SS	98.5	33,9	44	44	L1	F
WAIXL1	500	-	1 1/4"	316L SS	98.5	33,9	44	44	L1	F
WAIXL1	600	-	1 1/4"	316L SS	98.5	33,9	44	44	L1	F

(*) Suitable for: F= Flow sensors; A= Analytical electrodes

INSTALLATION FITTINGS FOR FLS F3.10

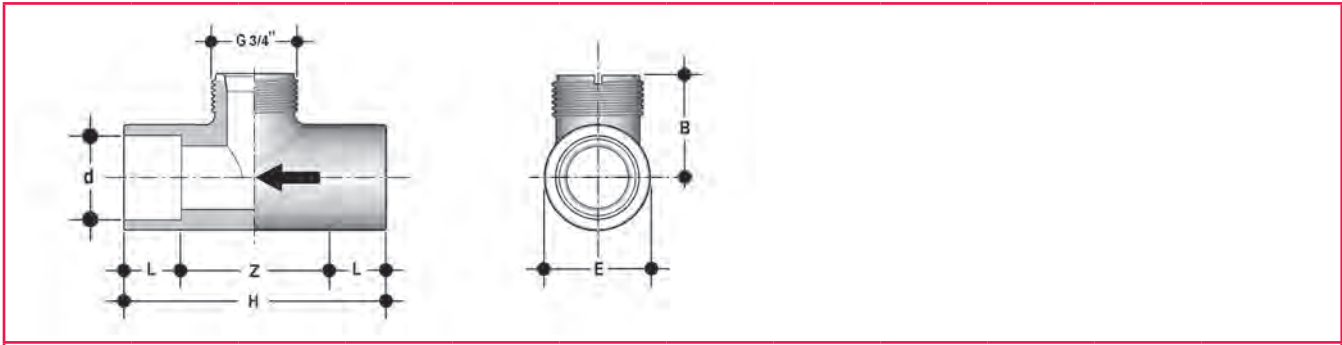

ISO Metric PVC Tee Fittings (female ends for solvent welding - PN10)

Part No.	DN/ Size	d/R	O-ring	Body	H	Z	L	B	E	Flow Sensor Lenght	Suitable for (*)
TMIV20MF	15	20	-	U-PVC	43	11	16	27	27	-	F
TMIV25MF	20	25	-	U-PVC	52	14	19	30	33	-	F
TMIV32MF	25	32	-	U-PVC	61,5	17,5	22	33,5	41	-	F
TMIV40MF	32	40	-	U-PVC	74	22	26	38	50	-	F
TMIV50MF	40	50	-	U-PVC	89	27	31	43	61	-	F

(*) Suitable for: F= Flow sensors; A= Analytical electrodes

INSTALLATION FITTINGS FOR FLS F3.20

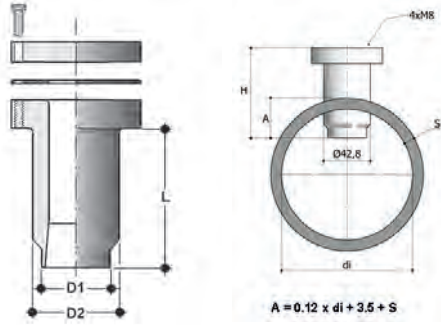

316L SS Weld-on Adapters

Part No.	DN/Size	d/R	Parallel Thread (GAS)	Body	L	D1	D2	Drilling Hole	Flow Sensor Length	Suitable for (*)
WAIXHP	40	-	1 1/4"	316L SS	68,5	34	42,8	34	-	F
WAIXHP	50	-	1 1/4"	316L SS	68,5	34	42,8	43	-	F
WAIXHP	60	-	1 1/4"	316L SS	68,5	34	42,8	43	-	F
WAIXHP	65	-	1 1/4"	316L SS	68,5	34	42,8	43	-	F
WAIXHP	80	-	1 1/4"	316L SS	68,5	34	42,8	43	-	F
WAIXHP	100	-	1 1/4"	316L SS	68,5	34	42,8	43	-	F
WAIXHP	110	-	1 1/4"	316L SS	68,5	34	42,8	43	-	F
WAIXHP	125	-	1 1/4"	316L SS	68,5	34	42,8	43	-	F
WAIXHP	150	-	1 1/4"	316L SS	68,5	34	42,8	43	-	F
WAIXHP	175	-	1 1/4"	316L SS	68,5	34	42,8	43	-	F
WAIXHP	200	-	1 1/4"	316L SS	68,5	34	42,8	43	-	F

(*) Suitable for: F= Flow sensors; A= Analytical electrodes



HOT TAP INSERTION INSTALLATION

INSTALLATION ON METAL AND PLASTIC PIPES

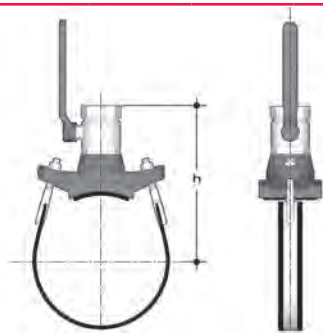

Strap-on Saddles (PN16) ***

Part No.	DN/Size	O.D. min.	O.D. max	Parallel Thread (GAS)	O-ring	Body	Insert	h	Drilling Hole	Flow Sensor Length	Suitable for (*)
SZIC080IHT	80	88	104	2.00"	EPDM	Cast iron + SS	-	160	min 32	-	F
SZIC100IHT	100	112	126	2.00"	EPDM	Cast iron + SS	-	170	min 32	-	F
SZIC125IHT	125	140	154	2.00"	EPDM	Cast iron + SS	-	172	min 32	-	F
SZIC150IHT	150	168	184	2.00"	EPDM	Cast iron + SS	-	172	min 32	-	F
SZIC200IHT	200	218	234	2.00"	EPDM	Cast iron + SS	-	177	min 32	-	F
SZIC250IHT	250	272	286	2.00"	EPDM	Cast iron + SS	-	175	min 32	-	F
SZIC300IHT	300	322	344	2.00"	EPDM	Cast iron + SS	-	178	min 32	-	F
SZIC350IHT	350	356	384	2.00"	EPDM	Cast iron + SS	-	178	min 32	-	F
SZIC400IHT	400	425	458	2.00"	EPDM	Cast iron + SS	-	171	min 32	-	F
SZIC450IHT	450	475	516	2.00"	EPDM	Cast iron + SS	-	180	min 32	-	F

*** Bigger sizes available on request

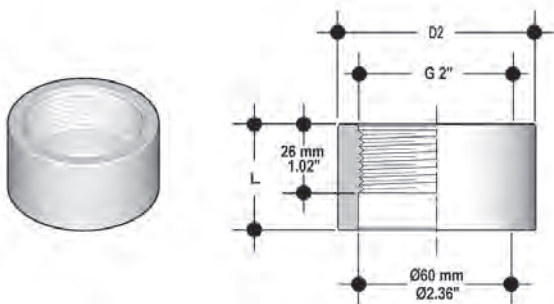

316L SS Weld-on Adapters









Part No.	DN/Size	d/R	Parallel Thread (GAS)	Body	L	D1	D2	Drilling Hole	Flow Sensor Length	Suitable for (*)
WAIXHT	350	-	2.00"	316L SS	40	-	75	min 32	-	F
WAIXHT	400	-	2.00"	316L SS	40	-	75	min 32	-	F
WAIXHT	450	-	2.00"	316L SS	40	-	75	min 32	-	F
WAIXHT	500	-	2.00"	316L SS	40	-	75	min 32	-	F
WAIXHT	600	-	2.00"	316L SS	40	-	75	min 32	-	F
WAIXHT	700	-	2.00"	316L SS	40	-	75	min 32	-	F
WAIXHT	800	-	2.00"	316L SS	40	-	75	min 32	-	F
WAIXHT	900	-	2.00"	316L SS	40	-	75	min 32	-	F

(*) Suitable for: F= Flow sensors; A= Analytical electrodes



SPECIFIC ADAPTERS FOR ANALYTICAL ELECTRODES INSTALLATION



ADAPTERS FOR IN-LINE, SUBMERSIBLE AND WET-TAP INSTALLATION

In-line					
	Part No.	Body	Description	Suitable for	Weight (gr.)
	EG12SS	SS	1/2" male Electrode Gland	C300	300
	TCONIV32E	U-PVC	T fitting d32 DN25 (including NBR o-ring)	C150-200	500
	TCONIV40E	U-PVC	T fitting d40 DN32 (including NBR o-ring)	C150-200	550
	TCONIV50E	U-PVC	T fitting d50 DN40 (including NBR o-ring)	C150-200	600
	TCONIC32E	C-PVC	T fitting d32 DN25 (including NBR o-ring)	C150-200	500
	TCONIC40E	C-PVC	T fitting d40 DN32 (including NBR o-ring)	C150-200	550
	TCONIC50E	C-PVC	T fitting d50 DN40 (including NBR o-ring)	C150-200	600
	TPHIV32E	U-PVC	T fitting d32 DN25 (including NBR o-ring)	PH/ORP.200 (excluded PH223CD; ORP223CD)	500
	TPHIV40E	U-PVC	T fitting d40 DN32 (including NBR o-ring)	PH/ORP.200 (excluded PH223CD; ORP223CD)	550
	TPHIV50E	U-PVC	T fitting d50 DN40 (including NBR o-ring)	PH/ORP.200 (excluded PH223CD; ORP223CD)	600
	TPHIC32E	C-PVC	T fitting d32 DN25 (including NBR o-ring)	PH/ORP.200 (excluded PH223CD; ORP223CD)	500
	TPHIC40E	C-PVC	T fitting d40 DN32 (including NBR o-ring)	PH/ORP.200 (excluded PH223CD; ORP223CD)	550
	TPHIC50E	C-PVC	T fitting d50 DN40 (including NBR o-ring)	PH/ORP.200 (excluded PH223CD; ORP223CD)	600
	TPHIC32C	C-PVC	T fitting d32 DN25	PH660-ORP660	500
	TPHIC40C	C-PVC	T fitting d40 DN32	PH660-ORP660	550
	TPHIC50C	C-PVC	T fitting d50 DN40	PH660-ORP660	600
	EG66P	C-PVC	3/4" male Electrode Gland	PH660-ORP660	45
	MK660	C-PVC	Installation KIT (adapter + yellow cap) for FLS fittings up to DN100 (4") (including FPM o-ring)	PH660-ORP660	165
	MK150200	C-PVC	Installation KIT (EG50P, adapter, yellow cap) for FLS fittings up to DN100 (4") (including NBR and FPM o-ring)	C150.1 TC	
	GEG135SE	PP	gland electrode for PG13.5 electrode with electrode head protection 1 1/4" G.M.	PH435CD	500
	F3.SP.2.4	U-PVC	Yellow Electrode Cap for FLS fittings up to DN100 (4")	PH223CD; ORP223CD	60

ADAPTERS FOR IN-LINE, SUBMERSIBLE AND WET-TAP INSTALLATION

In-line / Submersible					
	Part No.	Body	Description	Suitable for	Weight (gr.)
	GEG135	PVCU	gland electrode for PG13.5 electrode or o 12mm body 1/2" G.M. (including FPM o-rings)	PH-ORP.400	70
	EG50P	PP	1/2" male Electrode Gland (including NBR o-ring)	PH-ORP.200 (excluded PH223CD; ORP223CD), C150-200, T970278; T970196	45
	EG75P	PP	3/4" male Electrode Gland (including NBR o-ring)	PH-ORP.200 (excluded PH223CD; ORP223CD), C150-200, T970278; T970196	45
	EG135FS	PVDF/FPM	short gland electrode for PG13.5 electrode 1/2" (including FPM o-ring)	PH435CD	40
	EG135FL	PVDF/FPM	long gland electrode for PG13.5 electrode 1/2" (including FPM o-ring)	PH435CD	65

Submersible					
	Part No.	Body	Description	Suitable for	Weight (gr.)
	MIFV20X05	PVCU	Double socket 20*1/2" (pipe customer supplied)	PH200C-ORP200C, PH222CDTC (with EG50P), PH222CD-ORP222CD (with CN653), (GEG135), PH650-ORP650 (with CN653), C150-200 (with EG50P)	30
	MIMC20X05	C-PVC	Double socket 20*1/2" (pipe customer supplied)	PH200C-ORP200C, PH222CDTC (with EG50P), PH222CD-ORP222CD (with CN653), PH650-ORP650 (with CN653), C150-200 (with EG50P)	30

Hot tap or horizontal					
	Part No.	Body	Description	Suitable for	Weight (gr.)
	WT675	C-PVC	Electrode gland for hot tap installation: max insertion 300mm (12") (including FPM o-ring)	PH655-ORP655	700
	WT675 TC1	C-PVC,SS	Electrode gland for hot tap installation with TC: max insertion 300mm (12") (including FPM o-ring)	PH655-ORP655	880



SPARE PARTS AND ACCESSORIES
**FOR MONITORS, FLOW SENSORS
AND ANALYTICAL ELECTRODES**



SPARE PARTS

MONITOR SPARE PARTS

Spare Parts for monitors			
Part No.	Name	Description	Weight (gr.)
M9.SP4.1	PG 11	PG 11 complete cable gland (2 o-rings and cap)	12
M9.LN1	Locking nut	Plastic locking nut for M9.02, M9.20 and M9.00	24
M9.SN1	Fixing snails	2 plastic fixing snails for panel installation of all FLS Monitors (except for M9.02, M9.20 and M9.00)	16
M9.SP7	Replacement battery	3,6 V Lithium Thionyl Chloride battery (only for M9.20)	60

FLOW SENSORS SPARE PARTS

Spare Parts for F3.00			
Part No.	Name	Description	Weight (gr.)
F3.SP1	4 pole Cable Plug	Cable Plug according to DIN 43650	30
F3.SP2.1	Sensor Cap	Black Sensor Cap, for Hall version	42
F3.SP2.2	Sensor Cap	Red Sensor Cap, for Coil version	42
F3.SP2.4	Sensor Cap	Yellow Sensor Cap, for push-pull version	42
F3.SP2.6	Sensor Cap	SS 316L Sensor Cap, for SS 316L Hall and Coil versions	205
F3.SP3.1	O-Rings	EPDM Sensor body O-rings	4
F3.SP3.2	O-Rings	FPM Sensor body O-rings	4
F3.SP4.2	Rotor KIT	ECTFE (Halar®) rotor with Machined Ceramic Shaft and Bearings	8
F3.SP4.3	Rotor KIT	ECTFE (Halar®) rotor with SS 316L Shaft	8
F3.SP5.1	Sensor Plug	C-PVC Sensor Plug	140
F3.SP5.2	Sensor Plug	PVDF Sensor Plug	150
F3.SP5.3	Sensor Plug	SS 316L Sensor Plug	470
F3.SP6	Electrical cable	Cable (per meter), 22AWG, 3 cond.	28

Spare Parts for F3.20			
Part No.	Name	Description	Weight (gr.)
F3.SP4.3	Rotor KIT	ECTFE (Halar) rotor with SS 316L shaft	8
F3.SP8	Seal and screws kit	SS 316L screws + graphite gasket	70

Spare Parts for F6.30			
Part No.	Name	Description	Weight (gr.)
F6.KC1	Compact mounting kit	Plastic adapter with compact cap and locking nut	137
M9.SP4.1	PG 11	PG 11 complete cable gland (2 o-rings and cap)	12
F3.SP3.1	O-Rings	EPDM Sensor body O-Rings	4
F3.SP3.2	O-Rings	FPM Sensor body O-Rings	4
F6.30. SP1.S	Electronic device	Electronic device with 4-20 mA output and freq./volumetric pulse output for paddlewheel flow sensor	180
M9.KUSB	USB Cable	USB cable dedicated to FLS products, 1,5 meter long	60

Spare Parts for F3.10			
Part No.	Name	Description	Weight (gr.)
F3.SP2.7	Sensor Cap	Gray Sensor Cap	10
F3.SP3.3	O-Rings	EPDM Sensor body O-rings	2
F3.SP3.4	O-Rings	FPM Sensor body O-rings	2
F3.SP11	Rotor KIT	PVC rotor with 316L SS Shaft	2

FLOW SENSORS SPARE PARTS

Spare Parts for F3.05			
Part No.	Name	Description	Weight (gr.)
F3.SP1	4 pole Cable Plug	Cable Plug according to DIN 43650	30
F3.SP2.1	Sensor Cap	Black Sensor Cap for Hall version	42
F3.SP3.1	O-Rings	EPDM Sensor body O-rings	4
F3.SP3.2	O-Rings	FPM Sensor body O-rings	4
F3.SP4.2	Rotor KIT	ECTFE (Halar®) rotor with Machined Ceramic Shaft and Bearings	8
F3.SP5.1	Sensor Plug	C-PVC Sensor Plug	140
F3.SP5.2	Sensor Plug	PVDF Sensor Plug	150
F3.SP5.3	Sensor Plug	SS 316L Sensor Plug	470



Spare Parts for F6.60			
Part No.	Name	Description	Weight (gr.)
F6.KC1	Compact mounting kit	Plastic adapter with compact cap and locking nut	137
M9.SP4.1	PG 11	PG 11 complete cable gland (2 o-rings and cap)	12
F3.SP3.1	O-Rings	EPDM Sensor body O-Rings	4
F3.SP3.2	O-Rings	FPM Sensor body O-Rings	4
M9.KUSB	USB Cable	USB cable dedicated to FLS products, 1,5 meter long	60

Spare Parts for F6.61			
Part No.	Name	Description	Weight (gr.)
F6.KC1	Magmeter Compact mounting kit	Plastic adapter with compact cap and locking nut	137
M9.SP4.1	PG 11	PG 11 complete cable gland (2 o-rings and cap)	12
F1.SP3	Isolation Valve	2" Brass Ball Valve	1800
F1.SP6	2" to 1 1/4" Reduction	Zinc Plated Steel 2" BS male to 1 1/4" BS female	405
F1.SP7	2" to 1 1/4" Reduction	Zinc Plated Steel 2" NPT male to 1 1/4" BS female reduction	405
M9.KUSB	USB Cable	USB cable dedicated to FLS products, 1,5 meter long	60









ACCESSORIES

MONITOR ACCESSORIES

Accessories for monitors				
	Part No.	Name	Description	Weight (gr.)
	F6.KC1	Compact mounting kit	Plastic adapter with compact cap and locking nut (for M9.02, M9.20 and M9.00 only)	137
	M9.KW1	Wall mounting kit	144X144mm plastic box for wall installation of all panel mounting monitors	600
	M9.KW2	Wall mounting kit with power supply	144X144mm plastic box for wall installation of all panel mounting monitors and 110/230VAC to 24 VDC power supply included	900
	M9.KUSB	USB Cable	USB cable dedicated to FLS products, 1,5 meter long	60

ANALYTICAL ELECTRODES ACCESSORIES

Accessories for pH/ORP electrodes				
	Part No.	Name	Description	Weight (gr.)
	CN653	5m Universal cable assembly	Cable for PH222 CD, PH223 CD, ORP222 CD, ORP223 CD, PH-ORP.600	300
	CN65310M	10m Universal cable assembly	Cable for PH222 CD, PH223 CD, ORP222 CD, ORP223 CD, PH-ORP.600	400
	CN65315M	15m Universal cable assembly	Cable for PH222 CD, PH223 CD, ORP222 CD, ORP223 CD, PH-ORP.600	500
	CN653TC1	5m Submersible cable assembly with Temperature compensation (PT 100)	Cable for PH650CD, PH650CD HF, PH650CD DA, PH650CD LC	350
	CE5S7	5m Cable assembly	Cable for PH435 CD	300
	CE10S7	10m Cable assembly	Cable for PH435 CD	400
	CE15S7	15m Cable assembly	Cable for PH435 CD	500
	B104	pH buffer	Buffer pH 4,01	450
	B107	pH buffer	Buffer pH 7,00	450
	B110	pH buffer	Buffer pH 10,00	450
	B3KCL	pH buffer	3KCl solution	500
	B475	ORP buffer	Buffer 475mV	450

Accessories for Conductivity Sensors				
	Part No.	Name	Description	Weight (gr.)
	T970278	5m PT100 Temperature Epoxy body Sensor	2 wire PT100 Temperature Sensor with epoxy body	200
	T970196	5m PT100 Temperature Epoxy body Sensor	2 wire PT100 Temperature Sensor with epoxy body (no metal in contact)	200
	B0018	Conductivity buffer	Calibration solution for low conductivity (18 microsiemens/cm)	450
	B1417	Conductivity buffer	Calibration solution for conductivity (1417 microsiemens/cm)	450



TECHNICAL INFORMATION
**ABOUT FLOW AND ANALYTICAL
MEASUREMENT**



FLOW MEASUREMENT

FLOW MEASUREMENT

Insertion technology is based on fluid speed meters, properly installed in a cylindrical straight pipe, and used to measure the local flow velocity V_m to calculate the average velocity V_a and the volumetric flow rate Q_v . These flow sensors are theoretically supported by fluid-dynamic laws applicable to any circular cross section pipe when some physical conditions (fully developed turbulent flow) are respected.

Those laws state the relationship between the measured local flow velocity and the average flow velocity (UNI 10727; ISO 7145).

The relationship between average velocity V_a and measured velocity is usually expressed through the "Profile Factor":

$$F_p = V_a / V_m$$

Using the above mentioned factor:

$$Q_v = V_a * ID^2 / 4 = F_p * V_m * ID^2 / 4$$

ID = pipe inside diameter

Two different positions are suitable for the flow velocity measuring point:

1. Critical position: the velocity sensor is inserted in a peculiar point where the local velocity correspond to the average velocity (12% of Internal Diameter):

$$V_a = V_m \ggg F_p = 1.$$

2. Central position: the velocity sensor is placed exactly in the centre of the pipe cross section. The local velocity correspond to the maximum velocity:

$$V_m = V_{max} \ggg F_p < 1.$$

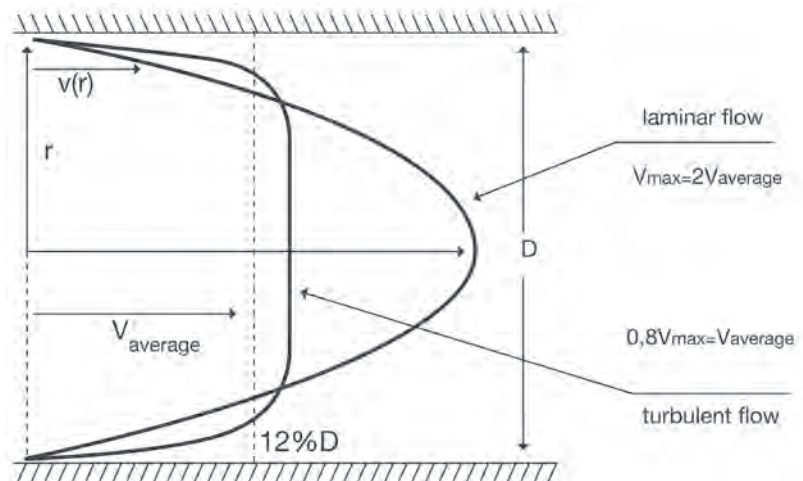

Fully Developed Turbulent Flow

All velocity based flow sensors provide an accurate and reliable indication only when they are measuring a fully developed turbulent flow. Fully developed turbulent flow occurs in every Newtonian fluid when the Reynolds Number is greater than 4500. Fully developed turbulent flow can be more difficult to achieve with high viscosity liquids, low flow rates or large pipes. Quite often a reduction of the pipe size to increase the local flow velocity is enough to produce a proper Reynolds Number:

$$Re = V \cdot ID \cdot Sg / \mu$$

where:

V = flow velocity in m/s

ID = pipe inside diameter in meter

Sg = Specific Gravity in Kg/m³

μ = Dynamic Viscosity in Pa*s
(1 Pa*s = 10³ cP)

or, converting flow velocity in flow rate:

$$Re = 1.2732 \cdot Qv \cdot Sg / \mu \cdot ID$$

where:

Qv = flow rate in l/s

Sg = Specific Gravity in Kg/m³

μ = Dynamic Viscosity in Pa*s
(1 Pa*s = 10³ cP)

ID = pipe inside diameter in meter

$$Re = 3162.76 \cdot Qv \cdot Sg / \mu \cdot ID$$

where:

Qv = flow rate in gpm

Sg = Specific Gravity in Kg/m³

μ = Dynamic Viscosity in centipoises
(1 Pa*s = 10³ cP)

ID = pipe inside diameter in inches

FLOW SENSORS OPERATING PRINCIPLE

Insertion flow sensor

Paddlewheel sensor

This flow sensor consists of a transducer (hall effect for powered system and coil for battery powered system) and a ECTFE five-blade (four blades for F3.10) open cell paddlewheel fixed on a ceramic shaft (SS in case of F3.10, F3.20 and SS version of F3.00). Shaft is orthogonal to the flow direction. The paddlewheel is equipped with a permanent magnet integrated into each blade. As the magnet passes close to the transducer a pulse is generated. When liquid flows into the pipe, the paddlewheel is set in rotation producing a square wave output signal. The frequency is proportional to the flow velocity. The sensor is installed into the pipe using a wide range of insertion type fittings supplied by FLS.

F3.05 Flow Switch

F3.05 is a flow switch based on a paddlewheel sensor from mechanical point of view.

This means that a transducer is present as well as a five-blade open cell paddlewheel. Also in this case, rotor is equipped with a permanent magnet integrated into each blade. As the magnet passes close to the transducer an output pulse is generated. That pulse is monitored by a missing signal circuit that trips an internal relay when the pulse frequency drops below the factory preset frequency of 0.15 m/s (0.5 ft/s). The switch is installed into the pipe using a wide range of insertion type fittings supplied by FLS.

Magmeter sensor

Magmeter sensor is based on Faraday's law since a voltage is induced in an electrical conductor when it moves in a magnetic field. A coil mounted into sensor body generates a magnetic field perpendicular to the flow direction. The magnetic field and the flow velocity induce a voltage between the electrodes. The voltage is directly proportional to the flow velocity.

The voltage is converted into a flow proportional 4-20mA output signal or frequency output signal.

In-line flow sensor

ULF sensor

This in-line flow sensor consists of a transducer and a five-blade paddlewheel (four-blade paddlewheel for ULF0X.X.0). The paddlewheel is equipped with a permanent magnet integrated into each blade. As the magnet passes close to the transducer a pulse is generated. When liquid flows into the sensor body, the paddlewheel is set in rotation producing a square wave output signal. The generated frequency is proportional to the flow velocity.

F3.80 Oval Gear sensor

This in-line sensor body contains two oval gears set into rotation by a flowing fluid. The two gears are meshed at 90° to define a fixed fluid volume pumped out every rotation.

Two permanent magnets are positioned into each gear and a hall effect sensor detects the magnetic field generating a square wave signal output with frequency proportional to the number of fluid volumes pumped out.

VELOCITY/FLOW RATE CONVERSION TABLES

Velocity [m/s] = (Flow Rate [l/s]*1273.2) / ID²								Flow Rate [l/s] = (Velocity [m/s]*ID²) / 1273.2								
		Velocity														
		ft/sec	0,16	0,33	0,5	0,7	1,6	2,6	3,3	6,6	9,8	13,1	16,4	20	23	26,2
		m/s	0,05	0,1	0,15	0,2	0,5	0,8	1	2	3	4	5	6	7	8
D [mm]	DN [mm]	Flow Rate l/s														
20	15	0,01	0,02	0,03	0,04	0,09	0,14	0,18	0,35	0,53	0,71	0,88	1,06	1,24	1,41	
25	20	0,02	0,03	0,05	0,06	0,16	0,25	0,31	0,63	0,94	1,26	1,57	1,89	2,20	2,51	
32	25	0,02	0,05	0,07	0,10	0,25	0,39	0,49	0,98	1,47	1,96	2,45	2,95	3,44	3,93	
40	32	0,04	0,08	0,12	0,16	0,40	0,64	0,80	1,61	2,41	3,22	4,02	4,83	5,63	6,43	
50	40	0,06	0,13	0,19	0,25	0,63	1,01	1,26	2,51	3,77	5,03	6,28	7,54	8,80	10,05	
63	50	0,10	0,20	0,29	0,39	0,98	1,57	1,96	3,93	5,89	7,85	9,82	11,78	13,74	15,71	
75	65	0,17	0,33	0,50	0,66	1,66	2,65	3,32	6,64	9,96	13,27	16,59	19,91	23,23	26,55	
90	80	0,25	0,50	0,75	1,01	2,51	4,02	5,03	10,05	15,08	20,11	25,13	30,16	35,19	40,21	
110	100	0,39	0,79	1,18	1,57	3,93	6,28	7,85	15,71	23,56	31,42	39,27	47,13	54,98	62,83	
125	110	0,48	0,95	1,43	1,90	4,75	7,60	9,50	19,01	28,51	38,01	47,52	57,02	66,53	76,03	
140	125	0,61	1,23	1,84	2,45	6,14	9,82	12,27	25,54	36,82	49,09	61,36	73,63	85,91	98,18	
160	150	0,88	1,77	2,65	3,53	8,84	14,14	17,67	35,34	53,02	70,69	88,36	106,03	123,70	141,38	
200	180	1,27	2,54	3,82	5,09	12,72	20,36	25,45	50,90	76,34	101,79	127,24	152,69	178,13	203,58	
225	200	1,57	3,14	4,71	6,28	15,71	25,13	31,42	62,83	94,25	125,67	157,08	188,50	219,92	251,34	
250	225	1,99	3,98	5,96	7,95	19,88	31,81	39,76	79,52	119,29	159,05	198,81	238,57	278,33	318,10	
280	250	2,45	4,91	7,36	9,82	25,54	39,27	49,09	98,18	147,27	196,36	245,44	294,53	343,62	392,71	
315	280	3,08	6,16	9,24	12,32	30,79	49,26	61,58	123,15	184,73	246,31	307,89	369,46	431,04	492,62	

Velocity [m/s] = (Flow Rate [l/min]*21.16) / ID²								Flow Rate [l/min] = (Velocity [m/s]*ID²) / 21.16								
		Velocity														
		ft/sec	0,16	0,33	0,5	0,7	1,6	2,6	3,3	6,6	9,8	13,1	16,4	20	23	26,2
		m/s	0,05	0,1	0,15	0,2	0,5	0,8	1	2	3	4	5	6	7	8
D [mm]	DN [mm]	Flow Rate l/min														
20	15	0,5	1,1	1,6	2,1	5,3	8,5	10,6	21,3	31,9	42,5	53,2	63,8	74,4	85,1	
25	20	0,9	1,9	2,8	3,8	9,5	15,1	18,9	37,8	56,7	75,6	94,5	113,4	132,3	151,2	
32	25	1,5	3,0	4,4	5,9	14,8	23,6	29,5	59,1	88,6	118,1	147,7	177,2	206,8	236,3	
40	32	2,4	4,8	7,3	9,7	24,2	38,7	48,4	96,8	145,2	193,6	242,0	290,4	338,8	387,1	
50	40	3,8	7,6	11,3	15,1	37,8	60,5	75,6	151,2	226,8	302,5	378,1	453,7	529,3	604,9	
63	50	5,9	11,8	17,7	23,6	59,1	94,5	118,1	236,3	354,4	472,6	590,7	708,9	827,0	945,2	
75	65	10,0	20,0	30,0	39,9	99,8	159,7	199,7	399,3	599,0	798,7	998,3	1198,0	1397,7	1597,4	
90	80	15,1	30,2	45,4	60,5	151,2	242,0	302,5	604,9	907,4	1209,8	1512,3	1814,7	2117,2	2419,7	
110	100	23,6	47,3	70,9	94,5	236,3	378,1	472,6	945,2	1417,8	1890,4	2362,9	2835,5	3308,1	3780,7	
125	110	28,6	57,2	85,8	114,4	285,9	457,5	571,8	1143,7	1715,5	2287,3	2859,2	3431,0	4002,8	4574,7	
140	125	36,9	73,8	110,8	147,7	369,2	590,7	738,4	1476,8	2215,3	2953,7	3692,1	4430,5	5169,0	5907,4	
160	150	53,2	106,3	159,5	212,7	531,7	850,7	1063,3	2126,7	3190,0	4253,3	5316,6	6380,0	7443,3	8506,6	
200	180	76,6	153,1	229,7	306,2	765,6	1225,0	1531,2	3062,4	4593,6	6124,8	7656,0	9187,1	10718,3	12249,5	
225	200	94,5	189,0	283,6	378,1	945,2	1512,3	1890,4	3780,7	5671,1	7561,4	9451,8	11342,2	13232,5	15122,9	
250	225	119,6	239,2	358,9	478,5	1196,2	1914,0	2392,5	4785,0	7177,5	9569,9	11962,4	14354,9	16747,4	19139,9	
280	250	147,7	295,4	443,1	590,7	1476,8	2362,9	2953,7	5907,4	8861,1	11814,7	14768,4	17722,1	20675,8	23629,5	
315	280	185,3	370,5	555,8	741,0	1852,6	2964,1	3705,1	7410,2	11115,3	14820,4	18525,5	22230,6	25935,7	29640,8	

VELOCITY/FLOW RATE CONVERSION TABLES

Velocity [m/s] = (Flow Rate [l/h] * 0.35344) / ID ²		Flow Rate [l/h] = (Velocity [m/s]*ID ²) / 0.35344													
		Velocity													
		ft/sec	0,16	0,33	0,5	0,7	1,6	3,3	6,6	9,8	13,1	16,4	20	23	26,2
		m/s	0,05	0,1	0,15	0,2	0,5	1	2	3	4	5	6	7	8
D [mm]	DN [mm]	Flow Rate l/h													
20	15	32	64	95	127	318	637	1273	1910	2546	3183	3820	4456	5093	
25	20	57	113	170	226	566	1132	2263	3395	4527	5659	6790	7922	9054	
32	25	88	177	265	354	884	1768	3537	5305	7073	8842	10610	12378	14147	
40	32	145	290	435	579	1449	2897	5794	8692	11589	14486	17383	20281	23178	
50	40	226	453	679	905	2263	4527	9054	13581	18108	22635	27162	31689	36215	
63	50	354	707	1061	1415	3537	7073	14147	21220	28293	35367	42440	49513	56587	
75	65	598	1195	1793	2391	5977	11954	23908	35862	47816	59770	71724	83678	95632	
90	80	905	1811	2716	3622	9054	18108	36215	54323	72431	90539	108646	126754	144862	
110	100	1415	2829	4244	5659	14147	28293	56587	84880	113173	141467	169760	198053	226347	
125	110	1712	3423	5135	6847	17117	34235	68470	102705	136940	171175	205410	239645	273880	
140	125	2210	4421	6631	8842	22104	44208	88417	132625	176833	221042	265250	309458	353667	
160	150	3183	6366	9549	12732	31830	63660	127320	190980	254640	318300	381960	445620	509280	
200	180	4584	9167	13751	18334	45835	91670	183341	275011	366682	458352	550023	641693	733364	
225	200	2659	11317	16976	22635	56587	113173	226347	339520	452694	565867	679040	792214	905387	
250	225	7162	14324	21485	28647	71618	143235	286470	429705	572940	716175	859410	1002645	1145880	
280	250	8842	17683	26525	35367	88417	176833	353667	530500	707334	884167	1061000	1237834	1414667	
315	280	11091	22182	33273	44364	110910	221820	443640	665459	887279	1109099	1330919	1552739	1774559	

Velocity [m/s] = (Flow Rate [l/h]*0.35344) / ID ²		Flow Rate [l/h] = (Velocity [m/s]*ID ²) / 0.35344														
		Velocity														
		ft/sec	0,16	0,33	0,5	0,7	1,6	2,6	3,3	6,6	9,8	13,1	16,4	20	23	26,2
		m/s	0,05	0,1	0,15	0,2	0,5	0,8	1	2	3	4	5	6	7	8
D [mm]	DN [mm]	Flow Rate m ³ /h														
20	15	0,03	0,06	0,10	0,13	0,32	0,51	0,64	1,27	1,91	2,55	3,18	3,82	4,46	5,09	
25	20	0,06	0,11	0,17	0,23	0,57	0,91	1,13	2,26	3,40	4,53	5,66	6,79	7,92	9,05	
32	25	0,09	0,18	0,27	0,35	0,88	1,41	1,77	3,54	5,31	7,07	8,84	10,61	12,38	14,15	
40	32	0,14	0,29	0,43	0,58	1,45	2,32	2,90	5,79	8,69	11,59	14,49	17,38	20,28	23,18	
50	40	0,23	0,45	0,68	0,91	2,26	3,62	4,53	9,05	13,58	18,11	22,63	27,16	31,69	36,22	
63	50	0,35	0,71	1,06	1,41	3,54	5,66	7,07	14,15	21,22	28,29	35,37	42,44	49,51	56,59	
75	65	0,60	1,20	1,79	2,39	5,98	9,56	11,95	23,91	35,86	47,82	59,77	71,72	83,68	95,63	
90	80	0,91	1,81	2,72	3,62	9,05	14,49	18,11	36,22	54,32	72,43	90,54	108,65	126,75	144,86	
110	100	1,41	2,83	4,24	5,66	14,15	22,63	28,29	56,59	84,88	113,17	141,47	169,76	198,05	226,35	
125	110	1,71	3,42	5,14	6,85	17,12	27,39	34,23	68,47	102,70	136,94	171,17	205,41	239,64	273,88	
140	125	2,21	4,42	6,63	8,84	22,10	35,37	44,21	88,42	132,63	176,83	221,04	265,25	309,46	353,67	
160	150	3,18	6,37	9,55	12,73	31,83	50,93	63,66	127,32	190,98	254,64	318,30	381,96	445,62	509,28	
200	180	4,58	9,17	13,75	18,33	45,84	73,34	91,67	183,34	275,01	366,68	458,35	550,02	641,69	733,36	
225	200	5,66	11,32	16,98	22,63	56,59	90,54	113,17	226,35	339,52	452,69	565,87	679,04	792,21	905,39	
250	225	7,16	14,32	21,49	28,65	71,62	114,59	143,24	286,47	429,71	572,94	716,18	859,41	1002,65	1145,88	
280	250	8,84	17,68	26,53	35,37	88,42	141,47	176,83	353,67	530,50	707,33	884,17	1061,00	1237,83	1414,67	
315	280	11,09	22,18	33,27	44,36	110,91	177,46	221,82	443,64	665,46	887,28	1109,10	1330,92	1552,74	1774,56	

VELOCITY/FLOW RATE CONVERSION TABLES

Velocity [f/s] = (Flow Rate [gpm]*0.4085) / ID ²							Flow Rate [gpm] = (Velocity [f/s]*ID ²) / 0.4085									
		Velocity														
		ft/sec	0,16	0,33	0,5	0,7	1,6	2,6	3,3	6,6	9,8	13,1	16,4	20	23	26,2
		m/s	0,05	0,1	0,15	0,2	0,5	0,8	1	2	3	4	5	6	7	8
D [inch]	DN [mm]	Flow Rate US-gpm														
1/2	15	0,14	0,28	0,42	0,56	1,40	2,25	2,81	5,62	8,43	11,24	14,05	16,85	19,66	22,47	
3/4	20	0,25	0,50	0,75	1,00	2,50	4,00	4,99	9,99	14,98	19,98	24,97	29,96	34,96	39,95	
1"	25	0,39	0,78	1,17	1,56	3,90	6,24	7,80	15,61	23,41	31,21	39,01	46,82	54,62	62,42	
1" 1/4	32	0,64	1,28	1,92	2,56	6,39	10,23	12,78	25,57	38,35	51,14	63,92	76,70	89,49	102,27	
1" 1/2	40	1,00	2,00	3,00	4,00	9,99	15,98	19,98	39,95	59,93	79,90	99,88	119,85	139,83	159,80	
2	50	1,56	3,12	4,68	6,24	15,61	24,97	31,21	64,42	93,63	124,85	156,06	187,27	218,48	249,69	
2" 1/2	65	2,64	5,27	7,91	10,55	26,37	42,20	52,75	105,49	158,24	210,99	263,74	316,48	369,23	421,98	
3	80	4,00	7,99	11,99	15,98	39,95	63,92	79,90	159,80	239,70	319,60	399,50	479,41	559,31	639,21	
4	100	6,24	12,48	18,73	24,97	62,42	99,88	124,85	249,69	374,54	499,38	624,23	749,07	873,92	998,76	
5	125	9,75	19,51	29,26	39,01	97,54	156,06	195,07	390,14	585,21	780,28	975,35	1170,42	1365,49	1560,56	
6	150	14,05	28,09	42,14	56,18	140,45	224,72	280,90	561,80	842,70	1123,61	1404,51	1685,41	1966,31	2247,21	
8	200	24,97	49,94	74,91	99,88	249,69	399,50	499,38	998,76	1498,14	1997,52	2496,90	2996,28	3495,66	3995,04	
10	225	31,60	63,20	94,80	126,41	316,01	505,62	632,03	1264,06	1896,08	2528,11	3160,14	3792,17	4424,20	5056,23	
12	300	48,94	97,88	146,82	195,76	489,39	783,03	978,79	1957,57	2936,36	3915,14	4893,93	5872,71	6851,50	7830,28	

VELOCITY/FLOW RATE CONVERSION TABLES

To convert		Into	Multiply by
VOLUME	US Gallon	fl. oz. (U.S.)	128
		cubic inch	231
		cubic ft.	0,134
		liter	3,785
		cubic meter	0,004
	Imperial Gallon	U.S. gallon	0,833
		U.S. gallon	1,201
	Cubic Foot	U.S. gallon	7,480
		Cubic meter	0,028
	Liter	U.S. gallon	0,264
Cubic meter		35,315	
Cubic meter	cubic ft.	264,172	
	U.S. gallon	264,172	
LENGTH	Inch	centimeter	2,540
	Foot	meter	0,305
	Yard	meter	0,914
	Mile	kilometer	1,609
WEIGHT	Ounce	gram	28,349
	Pound	gram	453,592
FLOW RATE	US gallon per minute (gpm)	liter per second	0,063
	US gallon per minute (gpm)	cubic meter per hr.	0,227
	UK gallon per minute (gpm)	cubic meter per hr.	0,273
PRESSURE	Atmosphere	bar	1,013
	Psi [lb/inch ²]	bar	0,069
	Pascal [Newton/m ²]	bar	1 * 10 ⁽⁻⁵⁾
	MegaPascal	bar	10
TEMPERATURE	Kelvin [°K]	celsius [°C]	°C = °K - 273.15
	Fahrenheit [°F]	celsius [°C]	°C = (°F - 32)*(5/9)



ANALYTICAL MEASUREMENT

PH MEASUREMENT

Definition

pH is defined as the negative logarithm of the hydrogen ion activity, a_{H^+} , in a solution.

So:

$$pH = -\log(a_{H^+})$$

pH Measuring technology

pH is measured using a setup with two electrodes: the measuring electrode and the reference electrode. These two electrodes are often combined into one which is defined as a "combined electrode". All pH electrodes supplied by FLS are "combined".

When the two electrodes are immersed in a solution, a small galvanic cell is established.

The potential developed is dependent on both electrodes.

The measured voltage can be expressed by the Nernst equation in the following way:

$$E = E_{meas} - E_{ref} = E_0 - (2,303RT/F)pH$$

where

E = Measured voltage

E_{meas} = Voltage of measuring electrode

E_{ref} = Voltage of reference electrode

E_0 = standard electrode potential

R = Gas Constant

T = Absolute Temperature

F = Faraday's constant

Then, it means that relationship between pH and E is linear correlated to the temperature.

The value of the slope at 25°C is 59,18 mV/pH. It is around 54 mV/pH at 5°C and around 62mV/pH at 40°C. At 100°C slope increases till around 74mV/pH.

pH technical terms

Calibration

Determination of offset and slope of a pH system.

In order to evaluate both electrode features calibration has to be performed for two pH points.

A calibration on sample solution can be done in order to consider chemical species which can affect pH measurement.

Calibration solution (Buffers)

A solution at known pH value which is used to calibrate the pH system.

Calibration solutions are affected by temperature.

The temperature dependency of the buffers is well known.

Following the dependency of buffers supplied by FLS:

°C	°F	pH buffer solution 4,01	pH buffer solution 7,00	pH buffer solution 10,00
0	32	4,01	7,12	10,31
5	41	4,00	7,09	10,24
10	50	4,00	7,06	10,17
15	59	4,00	7,04	10,11
20	68	4,00	7,02	10,05
25	77	4,01	7,00	10,00
30	86	4,01	6,99	9,95
35	95	4,02	6,98	9,92
40	104	4,03	6,97	9,88
45	113	4,04	6,97	9,85

pH technical terms

Reference temperature

pH readings are often referenced to a specific temperature, usually 25°C, for comparative purposes.

Automatic temperature compensation

Algorithms for automatic conversion of sample pH to a reference temperature.

This function considers the variation of pH slope with temperature.

pH electrode operating principle

The pH electrode is a very high-impedance galvanic cell in which the potential developed between the pH half-cell and the reference half-cell is the sum of various potentials. Figure A shows a typical glass combination pH electrode in which the pH half-cell and the reference half-cell are combined into a single design.

Ideally, all of the potentials are constant, except for one generated on the outer hydrated gel layer that depends on the pH of the sample according to the Nernst equation.

Real electrodes differ from an ideal electrode due to various factors, including:

- 1) manufacturing tolerances,
- 2) electrode aging,
- 3) electrode conditioning and cleaning.

All pH meters allow for calibration or standardization of the electrode to compensate for the above effects. A standard calibration involves measuring the response of the electrode in two pH buffer solutions with well known pH values and creating a linear map of the electrode response to these two points. This results in offset and slope correction factors, where the offset is the mV reading at pH 7 and the slope is the change in mV response per pH unit, usually expressed in mV/pH is a percentage of the ideal slope of the electrode (59.16 mV/pH at 25 °C).

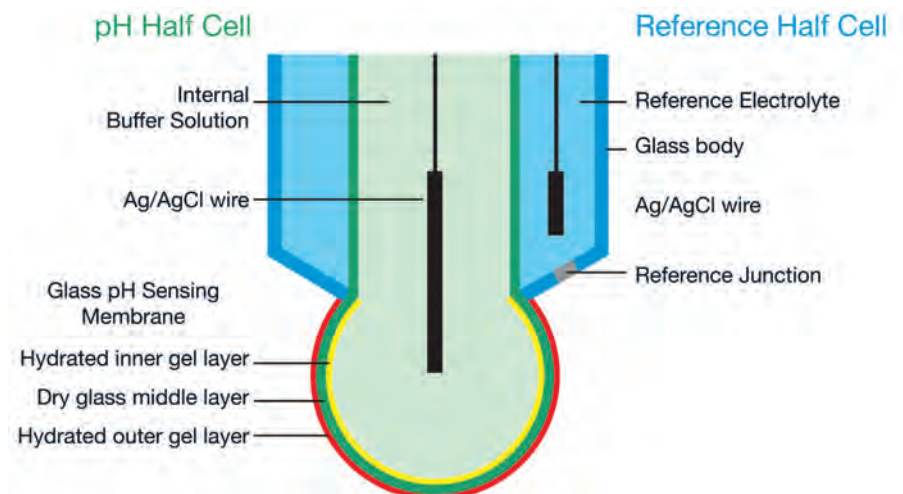

ORP MEASUREMENT

Definition

Oxidation-Reduction Potential (O.R.P.) is a measurement of the tendency of a solution to oxidize or to reduce what can be in contact with it. A oxidant solution is a liquid which tends to gain electrons oxidizing what is in contact reducing itself. A reductant solution is a liquid which tends to lose electrons reducing what is in contact oxidizing itself.

ORP Measuring technology

ORP electrode produces a voltage as well as pH electrode. In this case, measurement is not affected by hydrogen ions only, but it's affected by all chemical species which can give or receive electrons. Although ORP is affected by temperature and in principle it follows Nernst equation, it's difficult to compensate measurement as usually it's unknown how many electrons are involved into Redox reactions (in case ORP measurement is used to monitor a reaction only it's possible to determine main involved semi reaction and so it could be possible to do it). Also in ORP measurement, it's used a setup with two electrodes: the measuring electrode and the reference electrode. These two electrodes are often combined into one which is defined as a "combined electrode". All ORP electrodes supplied by FLS are "combined". When the two electrodes are immersed in a solution, a small galvanic cell is established. The potential developed is dependent on both electrodes and usually it moves from -1000mV up to +1000mV.

Although it's a no-specific measurement, it can be very useful to monitor and control activity of specific compounds. Applications that use ORP for monitoring and controlling oxidation-reduction reactions include cyanide destruction, dechlorination, nitrite and hydrosulfite oxidation, chromate reduction, hypochlorite bleach production, and chlorine and chlorine dioxide scrubber monitoring using bisulfite. Concentration measurement with ORP is problematic, but ORP can be used in some cases for leak detection to evaluate the presence of an oxidant or reductant. Finally, ORP is measured, in some instances, for the control of biological growth. The principle behind these applications is that a minimum ORP value will successfully destroy microorganisms. This approach has been used in the chlorination of swimming pools and cooling towers. It should be noted that both of these applications also include pH control.

ORP technical terms

Calibration

Determination of offset of a ORP system. The slope of ORP electrode is less variable than pH electrode since the ORP sensors are made of noble (more or less non-reactive) metals such as Platinum (suggested for strong oxidants contained chlorides and in general for Redox titration), Gold (preferred for strong acid solution and in presence of iron and chrome) or rarely Silver and do not change very much with use. Response times of these sensors depends on the surface area, size and construction, and how clean the sensor is. For most ORP applications, the absolute accuracy is less important than the speed and relative changes measured in the system. Many procedures and specifications call for target ORP values with tolerances of ± 25 mV, or ± 50 mV, or they specify changes in ORP such as a 400 mV drop in the value with a target end point value. Since ORP has a variety of uses with methods that have their own specialized target readings or reading changes that are based on experience, we can not elaborate on these in detail. It is sufficient to say the precision required for pH and other electrochemical measurements typically does not apply for ORP, and so calibration for ORP electrodes and meters is not so common.

ORP technical terms

Calibration solution

A solution at known ORP value which is used to check the ORP system. In principle, as explained previously, the absolute ORP value is not so important and then the use of a ORP calibration solution can applied just for checking purpose.

The main use of a calibration solution or a ORP reference solution is just to simplify comparison purpose.

In other words, a offset evaluation can be necessary in case of electrode replacement when the new probe measures a different value comparing to the former electrode and so a calibration can be necessary to align the new value to the former one.

If for example, a method calls for a target value of 410 mV which was defined with your previous electrode and instrument, the new electrode with the same instrument may read 425 mV in the same liquid. Using the calibration or, more properly, the offset adjustment, this 15 mV difference can be eliminated avoiding confusion. Then when the other readings occur, they can be comparable easily with those from the old electrode.

ORP electrode operating principle

The principle of ORP measurement is the use of an inert metal electrode (platinum, sometimes gold, rarely silver), which, due to its low resistance, will give up electrons to an oxidant or accept electrons from a reductant. The ORP electrode will continue to accept or give up electrons until it develops a potential, due to the build-up charge, which is equal to the ORP of the solution. The typical accuracy of an ORP measurement is ± 5 mV. Also ORP electrode needs a reference electrode which is typically the same silver-silver chloride electrode used with pH measurement.

CONDUCTIVITY MEASUREMENT

Definition

Conductivity is the ability of a solution to pass an electric current. In solutions the current is carried by cations and anions.

The solution capability to conduct electricity depends on a number of factors:

- Concentration
- Mobility of ions
- Valence of ions
- Temperature

All substances have a different level of conductivity. In aqueous solutions the level of ionic strength varies from the low conductivity of ultrapure water to the high conductivity of concentrated chemical samples.

Conductivity measuring technology

Conductivity may be measured by applying an alternating electrical current (I) to two electrodes immersed in a solution and measuring the resulting voltage (V). During this process, cations migrate to the negative electrode while anions to the positive electrode and the solution acts as an electrical conductor.

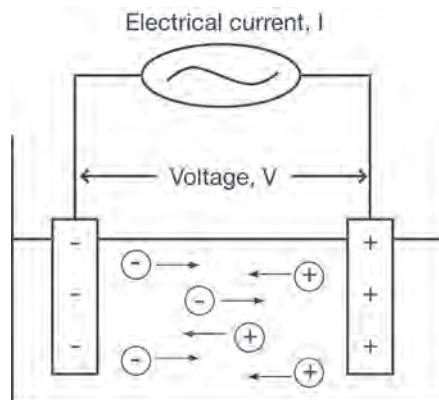

Conductivity technical terms

Resistance

The resistance of the solution (R) can be calculated using Ohm's law

$$(V = R \cdot I).$$

$$R = V/I$$

where:

V = voltage (volts)

I = current (amperes)

R = resistance of the solution (ohms)

Conductance

Conductance (G) is defined as the reciprocal of the electrical resistance (R) of a solution between two electrodes.

$$G = 1/R$$

The conductivity meter in fact measures the conductance, and displays the reading converted into conductivity.

Cell constant

This is the ratio of the distance (d) between the electrodes to the area (a) of the electrodes.

$$K = d/a$$

K = cell constant (cm⁻¹)

a = effective area of the electrodes (cm²)

d = distance between the electrodes (cm)

Conductivity

Electricity is the flow of electrons. This indicates that ions in solution will conduct electricity. Conductivity is the ability of a solution to pass current. The conductivity reading of a sample will change with temperature.

$$C = G \cdot K$$

C = conductivity (S/cm)

G = conductance (S), where $G = 1/R$

K = cell constant (cm⁻¹)

Resistivity

This is the reciprocal of the conductivity value and is measured in ohm•cm. It is generally limited to the measurement of pure water, the conductivity of which is very low.

Calibration

Determination of the cell constant required to convert conductance readings into conductivity results.

Standard solution

A solution of known conductivity that is used to calibrate the conductivity system.

Reference temperature

Conductivity readings are often referenced to a specific temperature, typically 18°C, 20°C or 25°C, for comparative purposes.

Automatic temperature compensation

Algorithms for automatic conversion of sample conductivity to a reference temperature.

Temperature compensation factor

Factor used for automatic compensation. Usually is considered as a % /°C.

For UPW application, on FLS instrumentation, is available a special correlation based on ASTM D1125-19.

Total Dissolved Solids (TDS)

This is the measure of the total concentration of ionic species of a sample. It is relative to the standard solution used to calibrate the instrument or to the salt solution to which user has decided to refer.

Conductivity technical terms

TDS factor

Conductivity readings are converted to TDS readings by multiplication with a known mathematical factor. The factor depends on the reference compound (usually a salt) used to prepare the standard or on the reference material considered. For example: seawater contains a lot of different salts but mainly NaCl, so user could refer just to it. Following few examples of factor:

Reference salts	Conversion factor range
NaCl	0,47-0,50
KCl	0,50-0,57
442 (40%NaSO ₄ +40%NaHCO ₃ +20%NaCl)	0,65-0,85

Conductivity operating principle

2-electrodes conductivity sensor

A 2-electrodes conductivity sensor is made up of an insulating material with 2 electrodes embedded. Electrodes can be made in platinum, graphite, stainless steel or other metallic materials. These metal contacts work as sensing elements and are placed at a fixed distance apart to make contact with a solution whose conductivity is to be determined. The distance between the sensing elements, as well as the surface area of the metallic piece, determine the electrode cell constant, defined as relationship distance/area. The cell constant is a critical parameter affecting the conductance value produced by the cell and handled by the electronic circuit.

A cell constant of 1.0 will produce a conductance reading approximately equal to the solution conductivity. For solutions of low conductivity, the sensing electrodes can be placed closer reducing the distance between them and producing cell constants of 0.1 or 0.01. This will raise the conductance reading by a factor of 10 to 100 to offset the low solution conductivity and give a better signal to the conductivity meter. On the other hand, the sensing electrodes can be placed farther to create cell constants of 10 for measurement of high conductive solutions. This also produces a conductance acceptable to the meter by reducing the conductance reading by a factor of 10.

In order to produce a measuring signal acceptable to the conductivity meter, it is highly important that the user choose a conductivity electrode with a cell constant appropriate for his sample. The table below lists the optimum conductivity range for generic probes with different cell constants.

Cell Constant	Optimum Conductivity Range
0.01	0.055 - 20 μ S/cm
0.1	0.5 - 200 μ S/cm
1.0	0.01 - 2 mS/cm
10.0	1 - 20 mS/cm

Conductivity technical terms

Inductive toroidal conductivity instrument

The inductive toroidal conductivity sensor is made up of two high-grade toroids (coils) which are incorporated concentrically and adjacent to one another in a non-conductive body. The primary coil is excited with a sinusoidal alternating voltage creating a changing magnetic field. This changing magnetic field causes the ions in the solution to move through the center of the toroid. This ion motion is equivalent to an AC current flowing through the center of the toroid. The AC current produces an AC current in the sensing coil that is proportional to the conductivity of the solution. Ideally the signal in the sensing coil should be due to the ion motion only and not due to the changing magnetic field created by the primary coil. For this reason good magnetic shielding is needed between the coils.

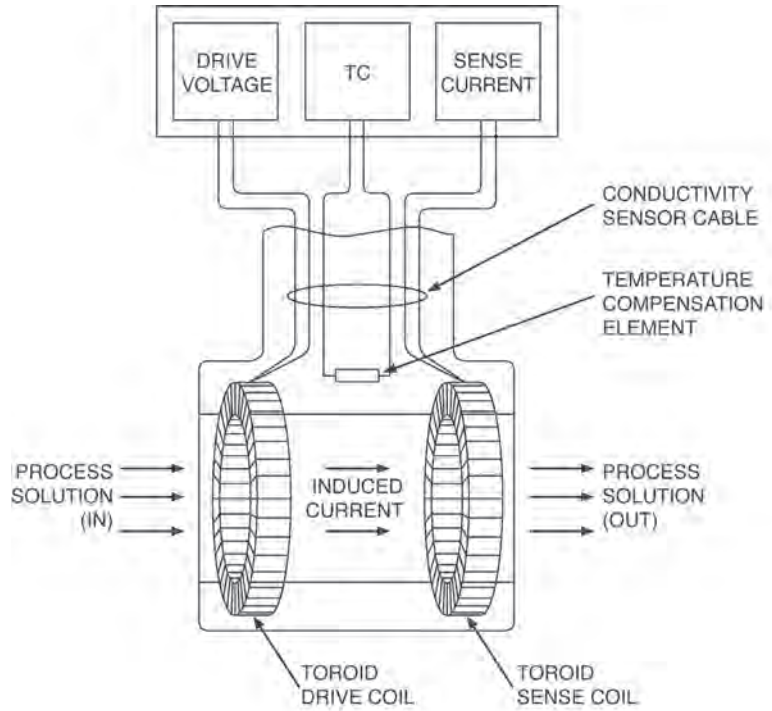



MISCELLANEA MEASUREMENT

HYDROSTATIC PRESSURE MEASUREMENT

Definition

Hydrostatic pressure is the pressure generated by the weight of liquid above a measurement point, when the liquid is at rest. The height of a liquid column, of uniform density, is directly proportional to the hydrostatic pressure.

Level measurement by hydrostatic pressure

The formula for calculating the hydrostatic pressure of a column of liquid is:

$$\begin{aligned} P_h &= h \cdot \rho \cdot g \\ P_g &= h \cdot \rho \cdot g \\ P_{abs} &= h \cdot \rho \cdot g + P_{atm} \end{aligned}$$

Symbols key:

- P_h = Hydrostatic Pressure (Pa)
- P_g = Relative Pressure (Pa)
- P_{abs} = Absolute Pressure (Pa)
- P_{atm} = Atmospheric Pressure (Pa)
- h = Liquid Height (m)
- ρ = Liquid Density (kg/m^3)
- g = Gravitational acceleration (m/s^2)

Liquid density is affected by temperature so, in case the temperature is not constant, the measurement quality can be affected according to the measured liquid (e.g. a variation of 20°C can affect the value of the constant level of water for a 0,2%).

Level measurement in open vessel

During the hydrostatic measurement in open basins or in vented containers, a continuous ambient air pressure compensation with the gas phase above the liquid occurs.

So the environmental pressure acting on the medium as an additional "force" that always resembles the environmental pressure acting on whole system, including the level sensor.

Thus, if you use a pressure transmitter equipped with a relative pressure measurement cell, a pressure sensor that is compensated or vented (just like the tank) to ambient pressure, it "automatically" compensates for the effect of this environmental pressure on the level measurement.

This means that a relative pressure transmitter in basins or in vented tanks "cancels" completely the atmospheric pressure overlapping on the liquid by measuring the level. So the hydrostatic pressure corresponds only at the filling height of the liquid.

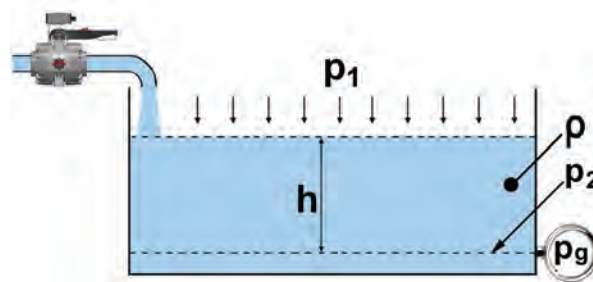

$$h = (p_2 - p_1) / (\rho \cdot g)$$

$p_g = (p_2 - p_1)$ = relative pressure (measured directly by gauge pressure instrument)

h = filling height / filling level

p_1 = atmosphere pressure

p_2 = pressure at depth h

ρ = liquid density

g = gravitational acceleration

Level measurement in sealed vessel

The level measurement in sealed, gas-tight containers, condition frequently faced in the chemical industry, requires the pressure compensation of the gas phase closed over the liquid.

The closed pressure of the gas phase acts as an extra force on the liquid and distorts any hydrostatic pressure measurement performed at the bottom of the vessel. So, in order to compensate this influence over hydrostatic measurement, an additional pressure sensor must be applied in order to monitor the gas phase.

This application requires a differential pressure measurement where the two separate pressure measurements are offset against each other. The evaluation of this compensation can be performed either by two individual pressure sensor (relative or absolute) or by an integrated differential pressure sensor.

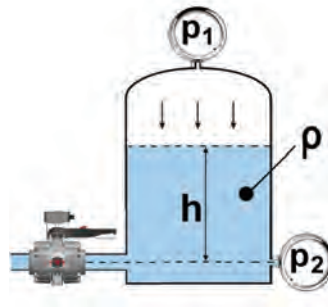

$$h = (p_2 - p_1) / (\rho * g)$$

h = filling height / filling level

p1 = pressure on surface generated by gas phase

p2 = pressure at depth h

ρ = liquid density

g = gravitational acceleration

NOTES

A series of 27 horizontal dashed lines providing space for writing notes.



Cod. LEFLSCAT 2017

Aliaxis

FIP Formatura Iniezione Polimeri

Loc. Pian di Parata, 16015 Casella Genova Italy

Tel. +39 010 9621.1

Fax +39 010 9621.209

info.fip@aliaxis.com

www.fipnet.com - www.flsnet.it

