

# Technical catalogue

PE Industrial system



Pressure piping fluids conveying



# Contents

General characteristics	3
Reference standards	5
Approvals and quality marks	6
Main properties	7
Butt welding instructions	8
Threaded joints instructions	15
Flanged joints instructions	16

## ISO-UNI pipe

Pressure pipe	20
---------------	----

## SPIGOT FITTINGS FOR BUTT- WELDING AND ELECTROFUSION

Short fittings for butt-welding	26
Long fittings for butt-welding	50

## ISO-BSP fittings

Adaptor fittings	76
------------------	----

## ELECTROFUSION fittings

Electrofusion fittings	80
------------------------	----

## CUSTOMIZED SOLUTIONS

Wall ducts	86
Seamless bend	89
Segmented fittings	90

## VALVES

VKD DN 15÷50	94
VKD DN 65÷100	106
VKR DN 15÷50	118
VXE DN 15÷50	128
VXE DN 65÷100	138
VEE DN 15÷50	150
VEE DN 65÷100	160
SXE-SSE DN 15÷50	172
SXE-SSE DN 65÷100	182
FE DN 40÷200	192
FK DN 40÷400	206
DK DN 15÷65	224



VM DN 80-100	236
CR DN 40-300	244
<b>Key abbreviations</b>	249

# General characteristics

## PE

**Aliaxis PE pressure fittings have been used for year in areas of application where the pipe system has to meet high standards of durability and reliability. These standards are met by combining the excellent material properties of PE and the experience in manufacturing plastic components**

Polyethylene (PE) is a semi-crystalline thermoplastic material which belongs to Polyolefins group.

Aliaxis PE-HD pressure pipes are ideal for applications in all areas of industrial plant engineering. Further main fields of application are the transport of industrial and domestic wastewater, wastewater treatment and water purification in sewage plants as well as various applications in swimming pools.

The mechanical properties of polyethylene are essentially dependent on density, degree of crystallization and the manufacturing process, which is reflected in the variety of types. Polyethylene of low density is extruded using high pressure and high temperature, while polyethylene of high density is extruded using low pressure and low temperature. An essential distinguishing feature consists in the main groups:

- **High Density Polyethylene, PE-HD (Density: 0.94 - 0.965 g/cm<sup>3</sup>).**
- **Medium density polyethylene, PE-MD (Density: 0.93 - 0.94 g/cm<sup>3</sup>).**
- **Low density polyethylene, PE-LD (Density: 0.9 - 0.91 g/cm<sup>3</sup>).**
- **Cross-linked polyethylene, PEX.**

Polyethylene is made by addition or radical polymerization of ethylene monomers. As regards chemical characteristics, PE is resistant to acids, bases, saline solutions, water, alcohol and oil.

<b>Density</b>	
Test method	DIN EN 1183
Unit of measurement	g/cm <sup>3</sup>
Value	0.95
<b>Modulus of elasticity</b>	
Test method	ISO 527, ASTM D 790
Unit of measurement	MPa = N/mm <sup>2</sup>
Value	900
<b>Charpy impact strength at 23°C</b>	
Test method	ASTM D256
Unit of measurement	KJ/m <sup>2</sup>
Value	16-26
<b>Ultimate elongation</b>	
Test method	ISO 527
Unit of measurement	%
Value	50
<b>Shore hardness</b>	
Test method	ISO 868
Unit of measurement	Shore D
Value	80
<b>Tensile strength</b>	
Test method	ISO 527
Unit of measurement	MPa = N/mm <sup>2</sup>
Value	23
<b>VICAT softening point (B/50)</b>	
Test method	ISO 306
Unit of measurement	°C
Value	127
<b>Heat distortion temperature HDT (0.46 N/mm<sup>2</sup>)</b>	
Test method	ASTM D648
Unit of measurement	°C
Value	75
<b>Thermal conductivity at 23°C</b>	
Test method	EN 12664
Unit of measurement	W/(m °C)
Value	0.38
<b>Coefficient of linear thermal expansion</b>	
Test method	DIN 53752 - ASTM D696
Unit of measurement	m/(m °C)
Value	20 x 10 <sup>-5</sup>
<b>Limiting Oxygen Index</b>	
Test method	ISO 4589-1 - ASTM D2863
Unit of measurement	%
Value	17

# Reference standards

## PE

**Production of the PE (100) lines is carried out according to the highest quality standards and in full compliance with the environmental restrictions set by the applicable laws in force and in accordance with ISO 14001.**

**All products are made in accordance with the quality guarantee system in compliance with ISO 9001.**

- **DVS 2202-1**

Imperfections of PE welded joints, characteristics, descriptions and evaluations

- **DVS 2207-1**

Welding of thermoplastics - Heated element welding of pipes, piping parts and panels made out of polyethylene

- **UNI EN 1555**

Plastics piping systems for the supply of gaseous fuels - Polyethylene

- **UNI EN 12201**

Plastics piping systems for water supply, and for drainage and sewerage under pressure - Polyethylene

- **EN 13244**

Plastics piping systems for buried and above-ground pressure systems for water for general purposes, drainage and sewerage - Polyethylene

- **ISO 4427**

Plastics piping systems for water supply and for drainage and sewerage under pressure - Polyethylene

- **ISO 21307**

Plastics pipes and fittings - Butt fusion jointing procedures for polyethylene

- **UNI 10520**

Welding of plastic materials - Welding for thermal elements by contact - Welding of polyethylene butt-joints pipes and/or fittings for the transport of fuel gas, water and other pressurized fluids

- **UNI 10521**

Welding of plastic materials - Electro-fusion welding - Welding of polyethylene pipes and/or fittings for pressure piping

- **EN 1092-1**

Flanges and their joints - Circular flanges for pipes, fittings, valves and accessories - Part 1: Steel flanges, PN designated.

- **EN ISO 15494**

Specifications for components (Pipes, Fittings and Valves) in PE for industrial applications.

- **ISO 7005-1**

Metallic flanges - Part 1: Steel flanges

- **ISO 9624**

Thermoplastics piping systems for fluids under pressure - Flange adapters and loose backing flanges - Mating dimensions

- **BS 10**

Specification for flanges and bolts for pipes, valves and fittings

- **ISO 4437**

Plastics piping systems for the supply of gaseous fuels - Polyethylene

# Approvals and quality marks



- **EAC**

FIP products are EAC certified in accordance with Russian regulations on Safety and Quality



- **RINA**

FIP PP-H valves, PE fittings and PE pipes have been recognised as suitable for conveying, treating domestic and air conditioning waters on board ships and other units classified by RINA.



- **UKR SEPRO**

FIP fittings and valves are certified in accordance with Ukrainian Health, Safety and Quality standards



- **DVGW Deutsche Vereinigung des Gas- und Wasserfaches (Germany)**

FIP and FRIALEN fittings are certified in accordance with Deutsche Vereinigung des Gas- und Wasserfaches



- **KIWA (Keurings Instituut voor Waterleiding Artikelen Holland)**

FIP fittings are certified in accordance with Keurings Instituut voor Waterleiding Artikelen











- **ACS France (Attestation de conformité Sanitaire)**

Suitability of PE fittings for drinking water



# Main properties

Properties of PE-HD	Benefits
<b>UV and weather resistance</b>	 <p>Especially black coloured PE-HD pipes are suitable for long-term outdoor use. The use of carbon black additives avoids the effects of prolonged exposure to intense UV light. This ensures the suitability of PE to use in an open environment.</p>
<b>Chemical resistance</b>	 <p>PE-HD has comprehensive chemical resistance. Due to its non-polar nature, PE-HD has good resistance to water, salt solutions, acids, alkalis, alcohols and many organic solvents, even at elevated operating temperatures. Conditional resistance is present with aromatics, PE-HD cannot be used with strong oxidizing agents. The chemical resistance depends on many factors: the most important influences are the operating temperature, the duration of exposure, and the concentration and composition of mixtures. Please contact us regarding the material resistance against specific chemicals or chemical mixtures.</p>
<b>Optimum thermal and mechanical properties</b>	 <p>According to literature, PE-HD can be used in the temperature range from - 40 °C to +60 °C, ensuring that the material has excellent mechanical properties in a wide range of applications. Regarding the internal pressure load capacity of pipes, fittings and armatures under the simultaneous influence of temperature, refer to PN diagrams of the respective material.</p>
<b>Resistance to ageing</b>	 <p>PE-100 resins have a high circumferential breaking strength (Minimum Required Strength MRS ≥ 10.0 MPa at 20°C) and allow long installation lifetimes without showing any signs of significant physical-mechanical deterioration. New pipes made of PE-HD certificated for DIN 8075, DIN 16892 have an operation time of minimum 100 years.</p>
<b>Abrasion resistance</b>	 <p>PE shows a very good amount of resistance against abrasion. It shows high abrasion resistance to mechanical stresses, especially against friction. PE is less likely to corrode in exposed and buried pipes. Thus, it ensures extremely low operating costs due to its long service life.</p>
<b>Mode of failure</b>	 <p>Generally, PE exhibits the mode of failure, which is brittle, initiation of slow crack growth (SCG) through the pipe wall. These cracks can initiate at microscopic stress-raising flaws, inherent in the basic pipe product or, more likely, from defects. However, over the years, PE has evolved and now provide a strong combination of strength, rigidity, reliability and longevity in line with long-term gas and water pressure needs, ground loading and the service environment. If this material is rapidly pulled apart, it breaks in a brittle fashion. However, once the material is gradually pulled apart, it acts in a ductile fashion and can be stretched nearly forever. In the last 50 years, the material development in PE is remarkable and PE-RC is evident to it. Thus, it shows a significant resistance against slow crack growth, being a very good material option for long-term application needs.</p>
<b>Combustion behaviour</b>	 <p>Polyethylene is a plastic flammable material. When exposed to an open flame, PE burns and the material continues to burn without soot after removing the flame. The oxygen index stands at 17%. (Materials that burn less than 21% of the air's oxygen are considered flammable). Carbon monoxide and water are formed when PE burns, primarily carbon dioxide.</p>
<b>Electrical properties</b>	 <p>PE-HD is a non-polar hydrocarbon polymer with excellent insulation properties. It possesses a specific volume resistance value of <math>3.5 \cdot 10^{14} \Omega \cdot m</math>. However, since the electrical charges cannot be dissipated, PE-HD also tends to become electrostatically charged. For this reason, PE-HD must not be used in applications with a risk of ignition and/or explosion, or only under certain conditions. For more details refer DVS Guidelines 2210-1.</p>

# Butt welding instructions

Butt welding with contact heating elements is the process of joining two elements (pipes and/or fittings) of the same diameter and thickness, the joining surfaces of which are heated until fusion by contact with a heating element and then, after the heating element has been removed, are pressed together to form the weld. The following instructions are provided for reference purposes only. Installers must be properly trained and have an in-depth knowledge of the procedures to be followed according to the type of welding equipment being used.

## Preliminary checks before welding

To ensure the joint is made properly:

- Ambient temperatures must be within the range from +5 °C to +40 °C.
- When inspecting the elements to be welded together, check the dimensions (check for excess ovality).
- Check the working temperature of the heating element with a calibrated contact thermometer. This measurement must be made 10 minutes after the rated temperature has been reached, thus allowing the element to heat up over its entire surface area and depth. Fusion temperature must be between 200° C and 220° C.
- Check the surface of the heating element (integrity of the non-stick coating) and clean with a lint-free cloth or soft paper wipe.
- Check that the welding unit is functioning correctly.
- Check the efficiency of the welding unit jaw clamps; ensure they are able to guarantee the correct alignment between the two sides of the joint and that the contact surfaces are perfectly parallel.
- Check the pulling force of the carriage, both in terms of friction and in relation to the load to be moved (pipes or fittings).
- Check the efficiency of the measuring instruments (pressure gauge and timer).
- Check that the pipes and/or fittings to be welded together are of the same diameter and thickness (same SDR).

## Preparing for welding

- **Cleaning the surfaces:** Before positioning the parts to be welded, remove all traces of dirt, grease, oil, dust, etc., from the external and internal surfaces of the ends, using a clean, lint-free cloth soaked in a suitable detergent. When choosing the type of liquid detergent, use recommended products supplied by specialist producers: trichloroethane, chlorothene, ethyl alcohol and isopropyl alcohol are all suitable.
- **Clamping the ends:** The ends of the two parts to be welded must be clamped in such a way that axial misalignment does not exceed 10% of the thickness (fig. 1).
- **Planing the edges to be welded:** to guarantee proper parallelism and flatness, and, equally important, to eliminate the film of oxide that forms, the ends of the two parts to be joined must be planed. When this procedure is concluded, bring the two ends into contact and ensure that any clearances between them do not exceed 0.5 mm. The shavings must form continuously on both the edges to be welded (fig. 2). It is good practice, after the planing stage, to inspect the resulting shavings to verify the absence of manufacturing defects. Shavings must be removed from the internal surface of the components to be welded using a brush or a clean cloth. In any event, after planing, the two surfaces must not be touched or contaminated in any other way; for this reason the welding operations must be performed immediately after preparation. If any traces of dust have settled on the planed surfaces, before they can be welded they should be cleaned with a cloth soaked in specific detergent.



Fig. 1 (this image is a generic reference)



Fig. 2 (this image is a generic reference)

## Butt welding procedure

The butt fusion welding of pipes and/or fittings using contact heating elements must be performed by carrying out all the steps in the welding cycle, and picture at the end of this chapter.

- **Equalizing:** As shown in the welding cycle, equalizing is the first step, where the two edges to be welded are located against the heating element at a pressure equal to  $p_1 + p_t$ , for the necessary time, with the purpose of creating a uniform internal and external bead (fig. 3).

This equalizing step is finished when the bead heights around the entire pipe circumference have reached the values specified in the next table. The equalizing pressure value must be such that, when in contact with the heating element, the surfaces to be welded are subjected to the pressure described in the table; to achieve this condition,  $p_1$  pressure values must be taken from the tables supplied by manufacturer of the fusion joining machine, because, apart from the diameter and thickness of the elements to be welded, these values also depend on the cross section of the thrust cylinder in the welder circuit and can therefore alter in accordance with the specific model of welding unit you are using. The symbol  $p_t$  indicates the pulling pressure required to overcome the friction offered by the welding unit and the weight of the pipe locked in the mobile guide, combining to impede the free movement of the guide. This reading is taken on the pressure gauge supplied with the machine, while moving the mobile guide (fig. 4). In any event, it must never be higher than the pressure value  $p_1$ , otherwise it may prove necessary to use carriages or suspension systems to facilitate movement of the pipe.

- **Pre-heating:** after the lip has formed, the pressure is lowered (10% of the contact and preheating value), thus allowing the material to heat up uniformly through its entire depth.

- **Changeover (Removing the heating element):** this phase must be performed as rapidly as possible, detaching the pipe edges to be welded from the heating element, extracting the element without damaging the softened surfaces and then immediately bringing the two edges to be welded into contact with each other. This procedure must be performed quickly to avoid the risk of excessive cooling of the edges (surface temperature falls by  $17\text{ }^\circ\text{C}$  in just 3 seconds)

- **Jointing build-up period:** the two edges are brought into contact and the relative pressure is increased progressively to the value  $(p_5 + p_t)$ , where  $p_5 = p_1$  and  $p_t$  is the pulling pressure (fig. 5).

- **Welding:** Welding pressure must be maintained for the time described in the cooling time for joining pressure column. (fig. 6).

- **Cooling:** once the joint has been welded, contact pressure is removed and the joined parts can be removed from the fusion joining machine, although it must not be subjected to mechanical stress until it has cooled completely. Time requested to get a complete cooling is the same described in the table in "Cooling time" column.

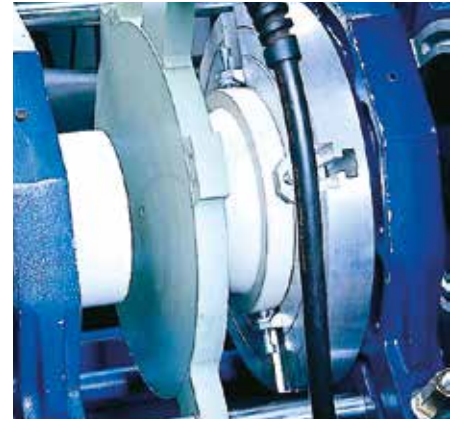

Fig. 3 (this image is a generic reference)



Fig. 4 (this image is a generic reference)

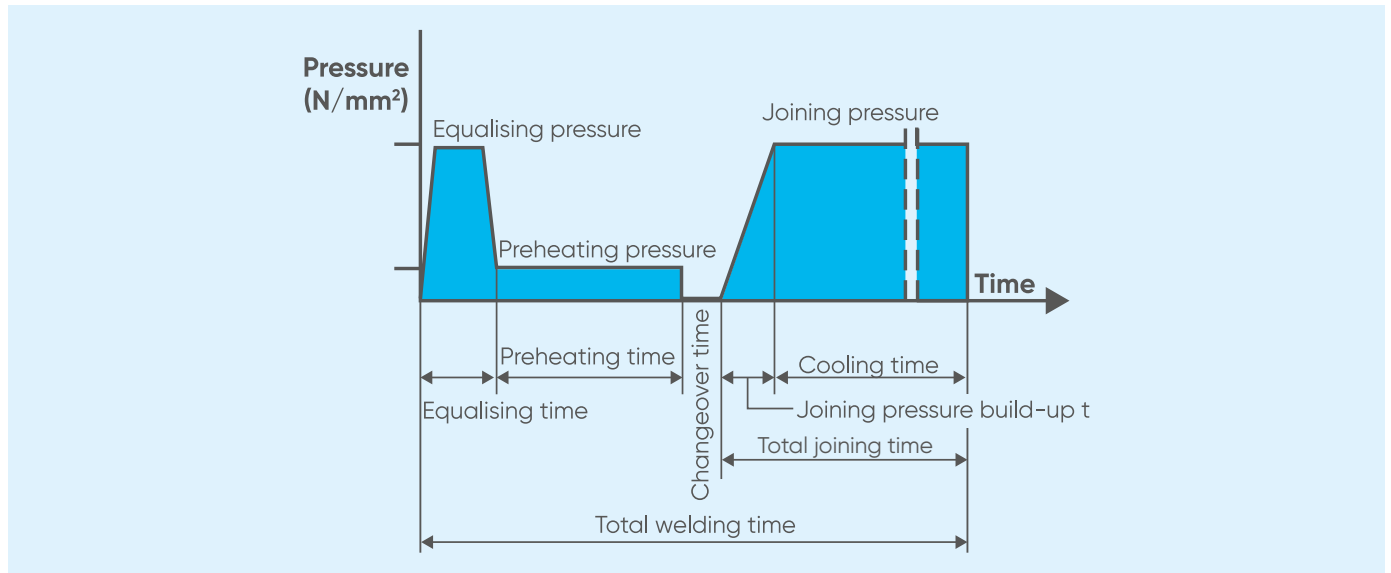

Fig. 5 (this image is a generic reference)



Fig. 6 (this image is a generic reference)

## Welding cycle



Nominal wall thickness (mm)	Equalizing Bead height on heating element at end of equalizing time (minimum values) (equalizing $p=0.15\pm0.01$ N/mm <sup>2</sup> ) (mm)	Preheating Preheating time = 10x nominal wall thickness (preheating $p\leq0.01$ N/mm <sup>2</sup> ) (sec)	Changeover Changeover time (maximum) (sec)	Joining pressure build-up time (Maximum time, may be undercut by up to 50%) (sec)	Cooling time (minimum values) at joining pressure $p=0.15\pm0.01$ N/mm <sup>2</sup> (min)
up to 4.5	0.5	up to 45	5	5	table below
4.5 - 7	1	45 - 70	5 - 6	5 - 6	
7 - 12	1.5	70 - 120	6 - 8	6 - 8	
12 - 19	2	120 - 190	8 - 10	8 - 11	
19 - 26	2.5	190 - 260	10 - 12	11 - 14	
26 - 37	3	260 - 370	12 - 16	14 - 19	
37 - 50	3.5	370 - 500	16 - 20	19 - 25	
50 - 70	4	500 - 700	20 - 25	25 - 35	
70 - 90	4.5	700 - 900	25 - 30	35	
90 - 110	5	900 - 1.100	30 - 35	35	
110 - 130	5.5	1.100 - 1.300	max. 35	35	

Nominal wall thickness (mm)	Cooling time (minimum values) at joining pressure $p=0.10\pm 0.01$ N/mm <sup>2</sup> as a function of ambient temperature		
	Up to 15°C (min)	15°C - 25°C (min)	25°C - 40°C Cooling time (min) (minimum values) at pressure welding $p= 0.10\pm 0.01$ N/mm <sup>2</sup> in special conditions* (min)
up to 4.5	4	5	6.5
4.5 - 7	4 - 6	5 - 7.5	6.5 - 9.5
7 - 12	6 - 9.5	7.5 - 12	9.5 - 15.5
12 - 19	9.5 - 14	12 - 18	15.5 - 24
19 - 26	14 - 19	18 - 24	24 - 32
26 - 37	19 - 27	24 - 34	32 - 45
37 - 50	27 - 36	34 - 46	45 - 61
50 - 70	36 - 50	46 - 64	61 - 85
70 - 90	50 - 64	64 - 82	85 - 109
90 - 110	64 - 78	82 - 100	109 - 133
110 - 130	78 - 92	100 - 118	133 - 157



#### WARNINGS

During the butt welding, take care of the following recommendations:

- Always wear appropriate personal protective equipment (for example, gloves and safety glasses to protect hands and eyes).
- Follow all the safety instructions specified by welding equipment manufacturer.
- It is a good practice, after the planing stage, to inspect the resulting shavings to verify the absence of manufacturing defects. Shavings must be removed from the internal surface of the components to be welded using a brush or a clean cloth.
- In any event, after planing, the two surfaces must not be touched or contaminated in any other way; for this reason, the welding operations must be performed immediately after preparation.
- If any traces of dust have settled on the planed surfaces, before they can be welded, they should be cleaned with a cloth soaked in specific detergent.

## Checking the quality of the welded joint

Joints can be checked using two alternative techniques: non-destructive tests and destructive tests. While these latter tests call for the use of special equipment, the quality of the joint can also be checked with a simple visual inspection.

Visual inspections should assess the following points:

- a) The weld bead must be uniform around the entire circumference of the joint;
- b) The notch in the centre of the bead must remain above the outside diameter of the welded parts;
- c) The external surface of the bead must not show any signs of porosity or inclusions of dust or other contaminants;
- d) There should be no visible signs of surface breakup;
- e) The surface of the weld bead should not have a very highly reflective finish, as this is a sign of overheating;
- f) Axial misalignment of the welded parts must be no greater than 10% of their thickness.

### Most common defects

The table reports the most common types of defect encountered if the correct welding procedure is not followed.

Irregular path of the weld bead around the circumference of the pipe	
Possible causes	Insufficiently meticulous preparation of ends to be welded with consequent uneven heat distribution
Reduced size of weld bead	
Possible causes	Incorrect adjustment of welding parameters (temperature, pressure and time)
Notch in centre of bead is too deep	
Possible causes	Temperature or pressure values are too low
Inclusions in the surface of the weld bead	
Possible causes	Insufficient cleaning of the ends to be welded
Porosity of weld bead	
Possible causes	Welding performed in excessively humid ambient conditions
Surface of weld bead presents an excessively smooth shiny finish	
Possible causes	Overheating during welding
Misalignment exceeds 10% of the thickness of the pipe and the fitting	
Possible causes	Incorrectly executed centring or excessive ovality of pipe

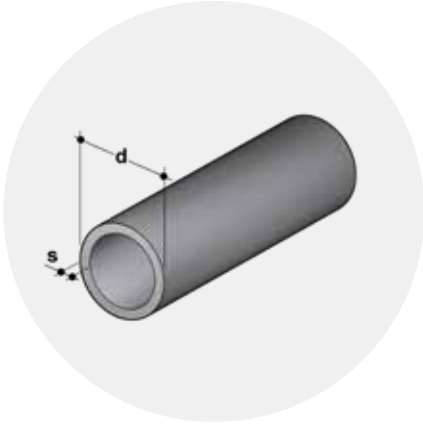

## Compatibility and safety factors

In accordance with standard EN ISO 15494, the safety factor to be adopted and the SDR/Series determine the reference nominal pressure value PN (PN: max. working pressure in bar at 20 °C, for a duration of 50 years, in water).

$$\text{SDR} = \frac{d}{s} \quad \sigma = \frac{\text{MRS}}{c} \quad s = \frac{(\text{SDR} - 1)}{2} \quad \text{PN} = \frac{\sigma}{S}$$

SDR	S
11	5
17	8
33	16

## Wall thickness

d	Wall thickness S (mm)		
	SDR 11 - ISO S 5	SDR 17 - ISO S 8	SDR 33 - ISO S 16
16	1.8	-	-
20	1.9	1.8	-
25	2.3	1.8	-
32	2.9	1.9	-
40	3.7	2.4	-
50	4.6	3	1.8
63	5.8	3.8	2
75	6.8	4.5	2.3
90	8.2	5.4	2.8
110	10	6.6	3.4
125	11.4	7.4	3.9
140	12.7	8.3	4.3
160	14.6	9.5	4.9
180	16.4	10.7	5.5
200	18.2	11.9	6.2
225	20.5	13.4	6.9
250	22.7	14.8	7.7
280	25.4	16.6	8.6
315	28.6	18.7	9.7
355	32.2	21.1	10.9
400	36.3	23.7	12.3
450	40.9	26.7	13.8
500	45.4	29.7	15.3
560	50.8	33.2	17.2
630	57.2	37.4	19.3
710	64.5	42.1	21.8
800	72.6	47.4	24.5
900	81.7	53.3	27.6
1000	90.8	59.3	30.6
1200	-	71.1	36.7
1400	-	83	42.9
1600	-	94.8	49
1800	-	106.6	55.1
2000	-	118.5	61.2
2250	-	-	68.9
2500	-	-	76.5



# Installation instructions for threaded joints

To guarantee the hydraulic seal of the joint on fittings and valves with a threaded female end, we recommend you perform the following operations:

- 1 Start winding some PTFE sealing tape on the outside of the threaded male end, taking care not to obstruct the through-hole on the pipe, fitting or valve (fig. 1);
2. Complete the first winding layer by winding the tape clockwise until you reach the root of the thread. Remember to keep the tape taut throughout the entire process (fig. 2);
3. Press on the tips of the thread to make sure the tape adheres fully to the support clip;
4. Increase the thickness of the PTFE layer by continuing to apply the taut tape and winding it clockwise until you achieve the optimal level (fig. 3);
5. Connect the previously sealed male end to the female end and proceed manually by screwing the two elements;
6. Make sure the layer of PTFE is not removed during screwing, as this would compromise the hydraulic seal of the joint;
7. Complete screwing the two ends exploiting the entire length of the thread with the aid of a strap wrench or similar tool;
8. Avoid tightening the elements too much, as this could damage the threads or cause stress to the elements themselves.

## Recommendations

For correct installation, we recommend you only use sealing tape in non-sintered PTFE. Under all circumstances avoid using materials such as hemp, lint or paints usually implemented for the hydraulic seal on metal threads.

## Warnings

Avoid using threaded joints in the following cases:

- highly critical applications, such as for conveying chemically aggressive or toxic fluids;
- in the presence of medium or high pressures. In this case, we recommend the use of solvent welding joints, hot welding joints or flanged joints;
- systems subject to mechanical and/or thermal stresses such as water hammers, strong variations in temperature, bends, misalignments and cross tensions which could cause the threaded joint to break prematurely;
- coupling of elements with excessive distance from one another.



**Fig. 1** (this image is a generic reference)



**Fig. 2** (this image is a generic reference)



**Fig. 3** (this image is a generic reference)

# Installation Instructions for flanged joints

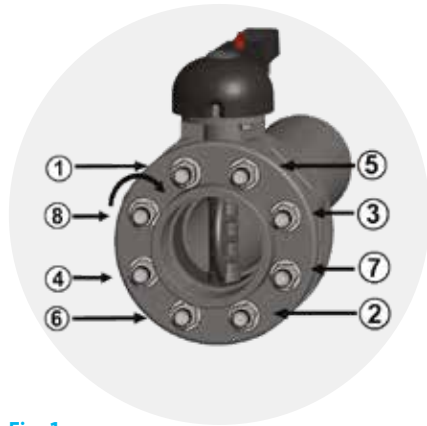

Fig. 1

To guarantee the correct installation of flanged elements, we recommend you perform the following operations:

1. insert the possible backing ring onto the pipe, before proceeding with the installation of the stub;
2. in the event of a fixed flange, check the drilling is correctly aligned with the counter flange;
3. check that the position of the counter flange takes into account the overall dimensions of the face to face distance of the components;
4. insert the flat gasket between the stubs (this step is not necessary for butterfly valves), making sure the sealing surfaces of the flanges to be welded have not been separated by an excessive distance, since this would cause it to compress;
5. proceed with solvent welding or welding of the fixed flanges or stub (in the case of backing rings) following the welding or solvent welding instructions provided;
6. insert all the bolts, washers and nuts;
7. once the cooling time is up, proceed with tightening the bolts in a "cross-wise" order (fig.1);
8. complete the bolt tightening process using a torque wrench until the tightening torque values shown in the table are reached.

## Tightening torque

Tightening torques for nuts and bolts to achieve the seal with flanges in PVC-U or PVC-C with gaskets in EPDM/FPM/NBR during the pressure test (1.5 x NP and water at 20°C).

DN	40	50	65	80	100	125	150	200	250	300	350	400
Nm	9	12	15	18	20	35	40	55	70	70	75	75

Please note that:

- the use of flanges in coated metal or fibreglass may allow the application of higher tightening torques, provided these do not exceed the elastoplastic limit of the material;
- the use of different elastomeric seal materials from those listed in the previous table may require slightly higher tightening torques,
- the use of suitably sized washers for any bolt used in the coupling flange.

## Minimum length of bolts

For flanged butterfly valves	
DN	Lmin
40	M 16x150
50	M 16x150
65	M 16x170
80	M 16x180
100	M 16x180
125	M 16x210
150	M 20x240
200	M 20x260
250	M 20x310
300	M 20x340
350	M 20x360
400	M 24x420

For flanged joints on pipes using backing rings		
d	DN	Lmin
20	15	M 12x70
25	20	M 12x70
32	25	M 12x70
40	32	M 16x85
50	40	M 16x85
63	50	M 16x95
75	65	M 16x95
90	80	M 16x105
110	100	M 16x105
125	125	M 16x115
140	125	M 16x120
160	150	M 20x135
200	200	M 20x140
225	200	M 20x140
250	250	M 20x150
280	250	M 20x160
315	300	M 20x180
355	350	M 20x180
400	400	M 24x180



# ISO-UNI PIPE

Pressure pipe

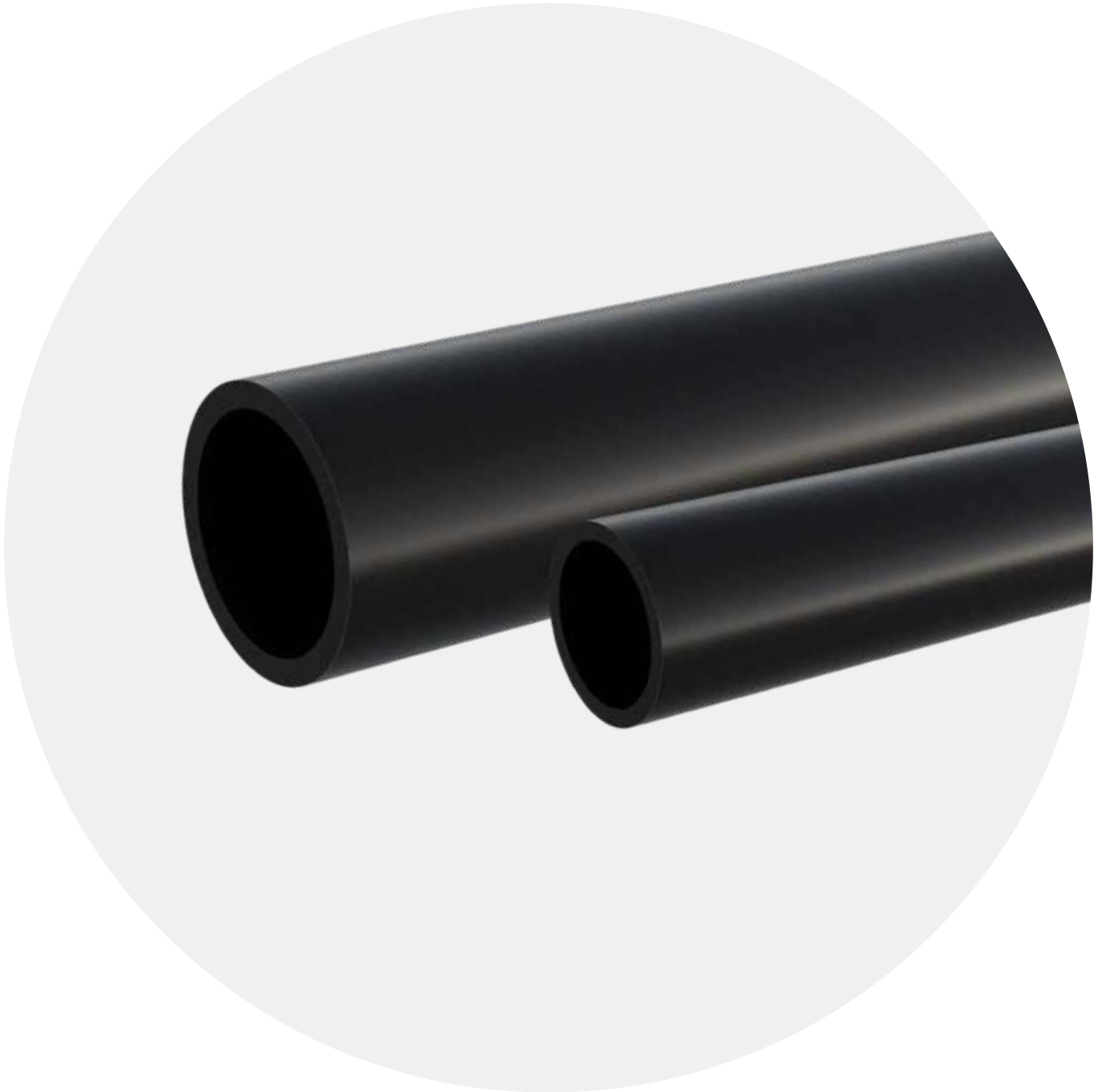

# ISO-UNI PIPE

Pressure pipe for connection system by  
butt welding

## PRESSURE PIPE

Technical specifications	
<b>Size range</b>	d 63 ÷ d 500 mm (SDR17) d 63 ÷ d 400 mm (SDR 11)
<b>Nominal pressure</b>	SDR 17 (PN10) with water at 20 °C SDR 11 (PN16) with water at 20 °C
<b>Temperature range</b>	-40 °C ÷ 60 °C
<b>Coupling standards</b>	<b>Welding:</b> EN ISO 15494
<b>Reference standards</b>	<b>Construction criteria:</b> UNI EN ISO 15494 <b>Test methods and requirements:</b> UNI EN ISO 15494 <b>Installation criteria:</b> DVS 2202-1, DVS 2207-1, UNI EN 12201-2, UNI 10520, ISO 21307, UNI 10521, UNI EN 1555-2, ISO 4427-2, ISO 4437-2
<b>Material</b>	Total black PE-HD material

# TECHNICAL DATA

## REGRESSION CURVES FOR PIPES IN PE

Regression coefficients in accordance with standards DIN and EN ISO for MRS = 10 N/mm<sup>2</sup>

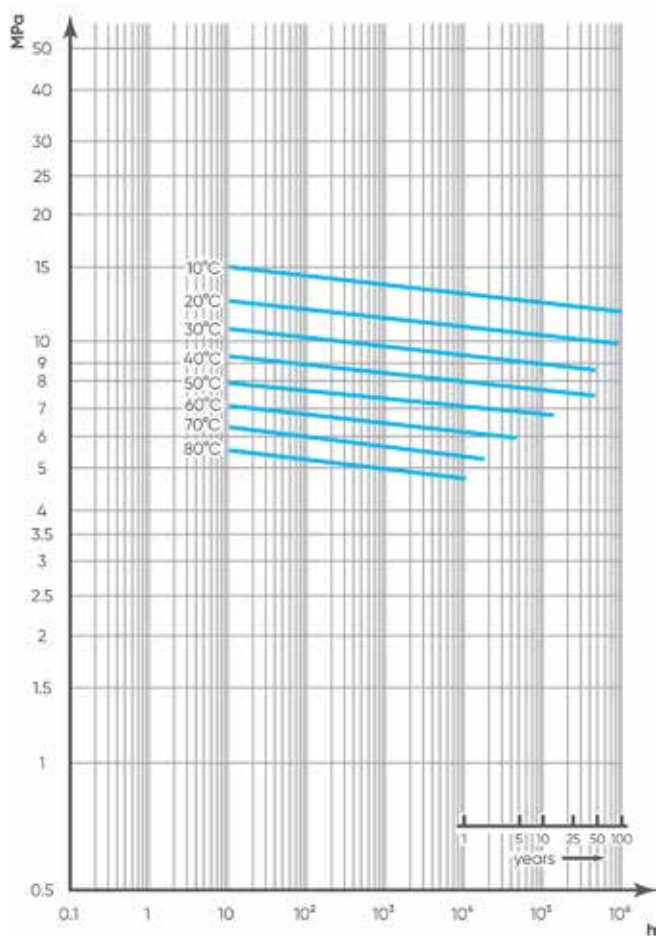

## PRESSURE VARIATION ACCORDING TO TEMPERATURE

For water and non-hazardous fluids with regard to which the material is classified as CHEMICALLY RESISTANT. In other cases, a reduction of the nominal pressure PN is required.  
 SDR 11 ISO-S5 - 25 years  
 SDR 17 ISO-S8 - 25 years  
 SDR 33 ISO-S16 - 25 years

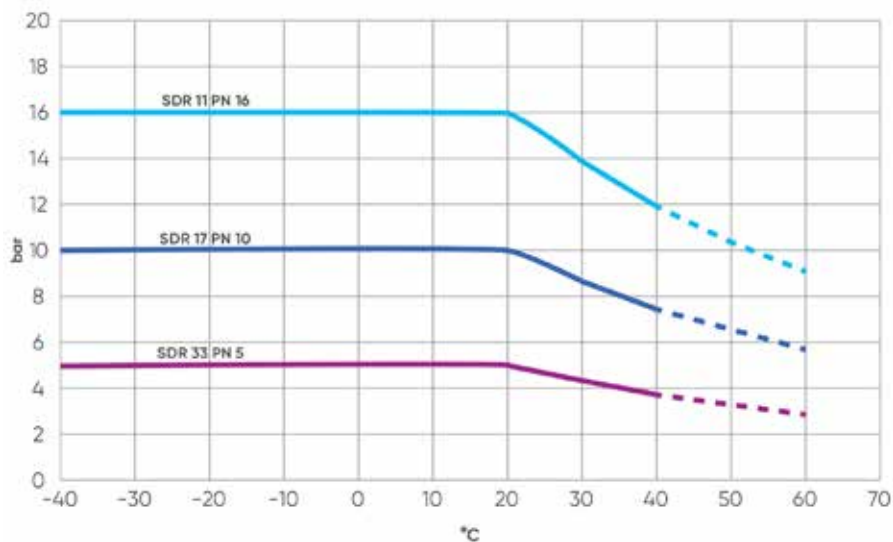

# DIMENSIONS



## PIPE SDR 17

Black PE100 pressure pipe, standard length 6 m, SDR 17 - S8

d	DN	S (mm)	kg/m
63	50	3,8	0,73
75	65	4,5	1,03
90	80	5,4	1,47
110	100	6,6	2,19
125	100	7,4	2,79
140	125	8,3	3,50
160	150	9,5	4,57
180	150	10,7	5,77
200	200	11,9	7,12
225	200	13,4	9,03
250	250	14,8	11,10
280	250	16,6	13,90
315	300	18,7	17,60
355	350	21,1	22,40
400	400	23,7	28,30
450	500	26,7	35,80
500	500	29,7	44,20

## PIPE SDR 11

Black PE100 pressure pipe, standard length 6 m, SDR 11 - S5

d	DN	S (mm)	kg/m
63	50	5,8	1,06
75	65	6,8	1,48
90	80	8,2	2,14
110	100	10,0	3,18
125	100	11,4	4,12
140	125	12,7	5,13
160	150	14,6	6,74
180	150	16,4	8,51
200	200	18,2	10,50
225	200	20,5	13,30
250	250	22,7	16,30
280	250	25,4	20,50
315	300	28,6	25,90
355	350	32,2	32,90
400	400	36,3	41,70

FM approved version available on request



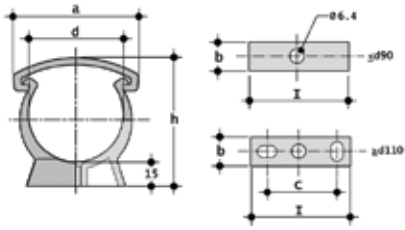

## ZIKM

Pipe clip for ISO-DIN pipes in PP

d	a	b	C	h	l	g	Code
16	26	18	-	33	16	5	ZIKM016
20	33	14	-	38	20	6,4	ZIKM020
25	41	14	-	44	25	7,8	ZIKM025
32	49	15	-	51	32	11,5	ZIKM032
40	58	16	-	60	40	15,7	ZIKM040
50	68	17	-	71	60	23,2	ZIKM050
63	83	18	-	84	63	28,8	ZIKM063
75	96	19	-	97	75	35,5	ZIKM075
90	113	20	-	113	90	52,4	ZIKM090
110	139	23	40	134	125	71	ZIKM110
140	177	27	70	167	155	149,5	ZIKM140
160	210	30	90	190	180	218,4	ZIKM160
180	237	33	100	211	200	293,6	ZIKM180

for pipe support systems, refer to guidelines DVS 2210-1 (Planning and execution - above-ground pipe systems)

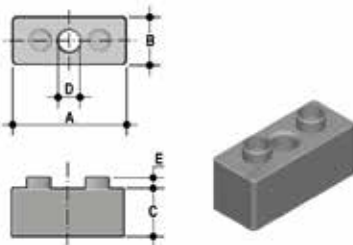

## DSM

Distance plates in PP for ZIKM pipe clips

d	A	B	C	D	E	g	Pack	Master	Code
32	33	16	14	8	4	6,4	20	120	DSM032
40	41	17	17	8	4	8,2	10	80	DSM040
50	51	18	17	8	4	9,8	10	50	DSM050
63	64	19	22,5	8	4	13,4	10	40	DSM063
75	76	20	34,5	8	4	20,2	10	40	DSM075

for pipe support systems, refer to guidelines DVS 2210-1 (Planning and execution - above-ground pipe systems)

# INSTALLATION

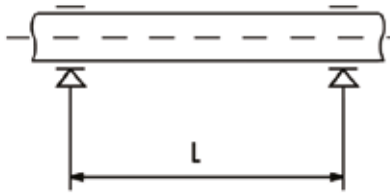

The installation of thermoplastic pipe systems requires the use of support clips to prevent flexing and the resulting mechanical stresses. The distance between the clips depends on the pipe material, SDR, surface temperature and the density of the conveyed fluid. Before installing the clips, check the distances reported in the table below, as provided for by guidelines DVS 2210-01 for water pipes.

## Supporting PE-HD pipes conveying liquids of density 1 g/cm<sup>3</sup> (water and other fluids of equal intensity)

For pipes of SDR 17 / S8 / PN10:

d mm	Nominal diameter DN	20 °C	30 °C	40 °C	50 °C	60 °C
16	10	500	450	450	400	350
20	15	575	550	500	450	400
25	20	650	600	550	550	500
32	25	750	750	650	650	550
40	32	900	850	750	750	650
50	40	1050	1000	900	850	750
63	50	1200	1150	1050	1000	900
75	65	1350	1300	1200	1100	1000
90	80	1500	1450	1350	1250	1150
110	100	1650	1600	1500	1450	1300
125	100	1750	1700	1600	1550	1400
140	125	1900	1850	1750	1650	1500
160	150	2050	1950	1850	1750	1600
180	150	2150	2050	1950	1850	1750
200	200	2300	2200	2100	2000	1900
225	200	2450	2350	2250	2150	2050
250	250	2600	2500	2400	2300	2100
280	250	2750	2650	2550	2400	2200
315	300	2900	2800	2700	2550	2350
355	350	3100	3000	2900	2750	2550
400	400	3300	3150	3050	2900	2700

\* For different SDR values, multiply the data in the table by the following factors:

• 1,07 for SDR 11 / S 5 / PN 16.

## Supporting PE-HD pipes conveying liquids of density other than 1 g/cm<sup>3</sup>.

If the liquid being conveyed has a density other than 1 g/cm<sup>3</sup>, the distance L must be multiplied by the factors in the table

Fluid density in g/cm <sup>3</sup>	Support factor
1	1
1,25	0,96
1,50	0,92

# SHORT AND LONG SPIGOT FITTINGS

For butt welding and electrofusion



# SHORT AND LONG SPIGOT FITTINGS

Series of short and long fittings designed for conveying fluids under pressure for butt welding and electrofusion applications.

## FOR BUTT WELDING AND ELECTROFUSION

Technical specifications	
<b>Size range</b>	d 12 ÷ d 800 (mm)
<b>Nominal pressure</b>	SDR 17 (PN10) with water at 20 °C, SDR 11 (PN16) with water at 20 °C
<b>Temperature range</b>	-40 °C ÷ 60 °C
<b>Coupling standards</b> <b>Reference standards</b>	<b>Welding:</b> EN ISO 15494. Can be coupled to pipes according to EN ISO 15494 <b>Flanging system:</b> ISO 7005-1, EN 1092-1, EN ISO 15494, ANSI B16.5 cl.150 <b>Construction criteria:</b> UNI EN ISO 15494 <b>Test methods and requirements:</b> UNI EN ISO 15494 <b>Installation criteria:</b> DVS 2202-1, DVS 2207-1, UNI EN 12201-3*, UNI 10520, ISO 21307, UNI 10521, UNI EN 1555-3*, ISO 4427-3, ISO 4437-3 *Short spigot fittings used for factory assemblies
<b>Fitting material</b>	PE-HD

# TECHNICAL DATA

## PRESSURE VARIATION ACCORDING TO TEMPERATURE

For water and non-hazardous fluids with regard to which the material is classified as CHEMICALLY RESISTANT. In other cases, a reduction of the nominal pressure PN is required.

SDR 11 ISO-S5 - 25 years  
SDR 17 ISO-S8 - 25 years  
SDR 33 ISO-S16 - 25 years

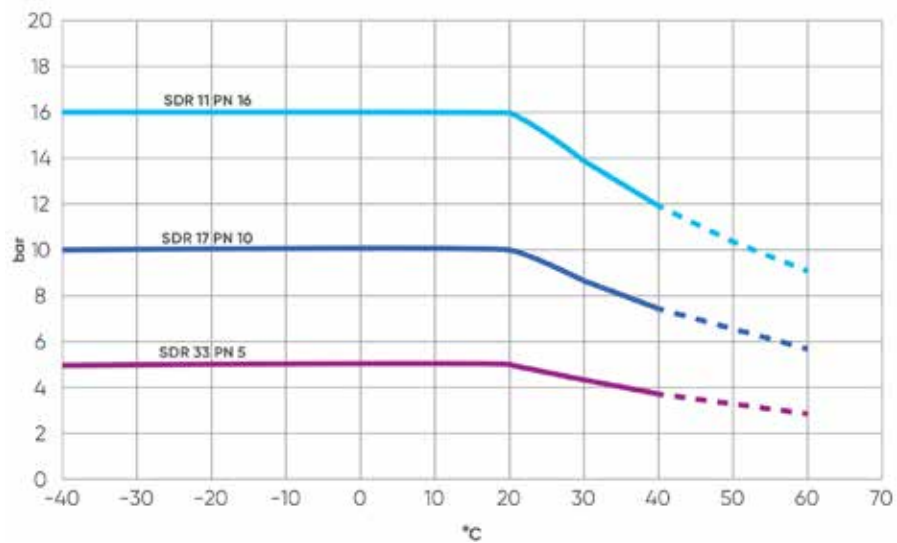

# DIMENSIONS

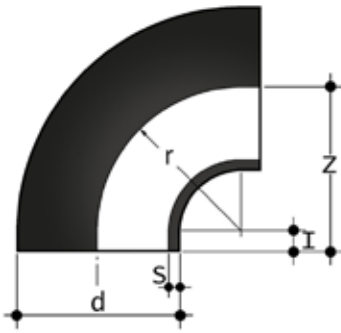

## GBE SDR33

90° bend, short spigot for butt welding SDR 33 - S 16

d	Z	l	r	S	g	PN5 code SDR 33 - S 16
*110	138	28	110	3,4	215	GBE33110
*125	130	15	125	3,9	352	GBE33125
*140	175	35	140	4,3	460	GBE33140
*160	200	40	160	4,9	745	GBE33160
*180	200	8	180	5,5	1220	GBE33180
*200	206	19	200	6,2	1740	GBE33200
*225	236	21	225	6,9	1944	GBE33225
*250	255	20	250	7,7	2439	GBE33250
*280	290	24	280	8,6	4380	GBE33280
*315	322	22	315	9,7	5020	GBE33315
*355	380	15	355	10,9	8900	GBE33355
*400	434	41	400	12,3	11040	GBE33400
*450	450	50	400	13,8	15000	GBE33450
*500	450	50	400	15,3	18480	GBE33500

\*resale products

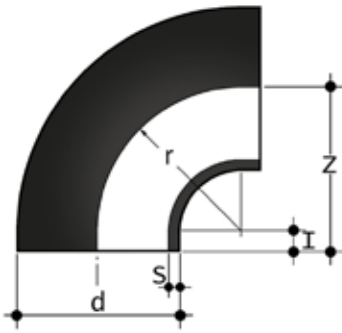

## GBE/GKE SDR17

90° bend, short spigot for butt welding SDR 17 - S 8

d	Z	l	r	S	g	PN10 code SDR 17 - S 8
50	62	23	36	3,0	52	GKE17050
63	77	21	65	3,8	107	GKE17063
75	85	21	75	4,5	146	GKE17075
90	100	22	90	5,4	248	GKE17090
110	120	25	110	6,6	437	GKE17110
125	140	15	125	7,4	681	GBE17125
140	155	15	140	8,3	986	GBE17140
160	175	15	160	9,5	1296	GBE17160
180	195	15	180	10,7	1972	GBE17180
200	215	15	200	11,9	2552	GBE17200
225	245	20	225	13,4	3565	GBE17225
250	275	25	250	14,8	5100	GBE17250
280	310	30	280	16,6	7005	GBE17280
315	350	35	315	18,7	10236	GBE17315
*355	380	38	355	21,1	13350	GBE17355
*400	432	41	400	23,7	20201	GBE17400
*450	510	60	450	26,7	42752	GBE17450
*500	560	60	500	29,7	53950	GBE17500

\*resale products

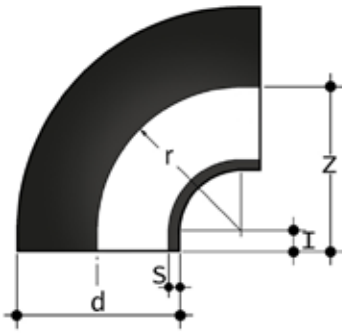

## GBE/GKE SDR11

90° bend, short spigot for butt welding SDR 11 - S 5

d	Z	l	r	S	g	PN16 code SDR 11 - S 5
20	34	20	18	1,9	7	GKE11020
25	37	20	18	2,3	12	GKE11025
32	40	21	20	2,9	20	GKE11032
40	51	22	35	3,7	40	GKE11040
50	62	23	36	4,6	74	GKE11050
63	77	21	65	5,8	148	GKE11063
75	85	21	75	6,8	212	GKE11075
90	100	22	90	8,2	361	GKE11090
110	120	25	110	10,0	635	GKE11110
125	140	15	125	11,4	1007	GBE11125
140	155	15	140	12,7	1391	GBE11140
160	175	15	160	14,6	1980	GBE11160
*180	184	15	180	16,4	2585	GBE11180
200	215	15	200	18,2	3885	GBE11200
225	245	20	225	20,5	5655	GBE11225
250	275	25	250	22,7	7652	GBE11250
280	310	30	280	25,4	10633	GBE11280
315	350	35	315	28,6	15279	GBE11315
*355	380	38	355	32,2	20825	GBE11355
*400	434	41	400	36,3	30214	GBE11400
*450	510	60	450	40,9	55482	GBE11450
*500	560	60	500	45,4	71250	GBE11500

\*resale products



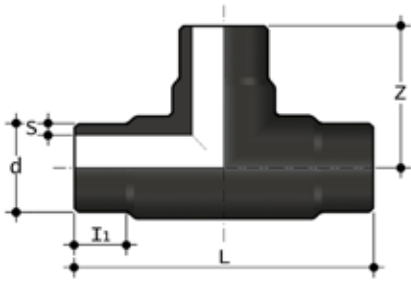

## TBE SDR33

90° Tee, short spigot for butt welding SDR 33 – S16

d	L	Z	I <sub>1</sub>	S	g	PN5 code SDR 33 – S 16
*110	215	105	30	3	664	TBE33110
*125	218	107	35	4	530	TBE33125
*140	253	125	20	4	1080	TBE33140
*160	270	140	40	5	1731	TBE33160
*180	310	150	45	6	2360	TBE33180
*200	340	170	45	6	3140	TBE33200
*225	440	220	48	7	4340	TBE33225
*250	438	215	52	8	7100	TBE33250
*280	500	243	65	9	8450	TBE33280
*315	535	270	77	10	10980	TBE33315
*355	674	347	96	11	16980	TBE33355
*400	680	340	90	12	23400	TBE33400
*450	890	450	130	14	33000	TBE33450
*500	895	450	130	15	33500	TBE33500

\*resale products

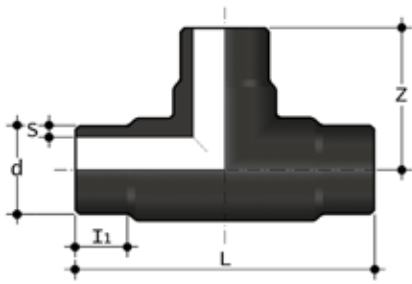

## TBE SDR17

90° Tee, short spigot for butt welding SDR 17 - S8

d	L	Z	I <sub>1</sub>	S	g	PN10 code SDR 17 - S 8
*50	100	50	13	3,0	86	TBE17050
63	156	78	29	3,8	182	TBE17063
75	180	90	33	4,5	310	TBE17075
90	200	100	23	5,4	513	TBE17090
110	240	120	43	6,6	840	TBE17110
125	250	125	26	7,4	1.170	TBE17125
140	280	140	32	8,3	1.635	TBE17140
160	350	160	40	9,5	2.402	TBE17160
180	390	195	73	10,7	3.503	TBE17180
225	490	245	72	13,4	7.417	TBE17225
*250	450	225	67	14,8	7.670	TBE17250
280	620	310	105	16,6	13.358	TBE17280
315	700	350	111	18,7	19.046	TBE17315
*355	699	348	103	21,1	23.640	TBE17355
*400	722	361	105	23,7	28.500	TBE17400
*450	838	419	137	26,7	47.500	TBE17450
*500	940	471	163	29,7	53.500	TBE17500

\*resale products

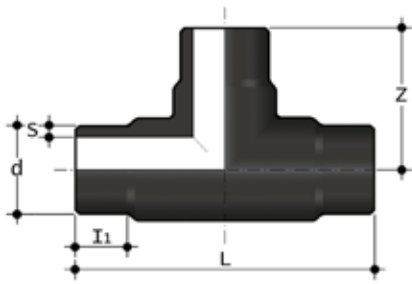

## TBE SDR 11

90° Tee, short spigot for butt welding SDR 11 - S5

d	L	Z	I <sub>1</sub>	S	g	PN16 code SDR 11 - S 5
*20	76	38	11	1,9	21	TBE11020
*25	84	40	11	2,3	30	TBE11025
32	80	40	12	2,9	32	TBE11032
*40	90	45	11	3,7	67	TBE11040
50	124	62	25	4,6	119	TBE11050
63	156	78	29	5,8	248	TBE11063
*75	153	75	19	6,8	394	TBE11075
*90	198	99	43	8,2	705	TBE11090
*110	254	127	55	10,0	1.260	TBE11110
*125	254	125	52	11,4	1.638	TBE11125
*140	314	153	65	12,7	2.690	TBE11140
*160	322	161	58	14,6	3.380	TBE11160
*180	430	214	94	16,4	5.740	TBE11180
*200	438	219	90	18,2	7.280	TBE11200
*225	452	226	76	20,5	9.615	TBE11225
*250	450	227	68	22,7	10.770	TBE11250
*280	530	265	87	25,4	15.950	TBE11280
*315	570	285	88	28,6	21.285	TBE11315
*355	698	349	103	32,2	31.320	TBE11355
*400	730	363	105	36,3	39.300	TBE11400
*450	837	419	137	40,9	65.520	TBE11450
*500	930	465	159	45,4	73.720	TBE11500

\*resale products

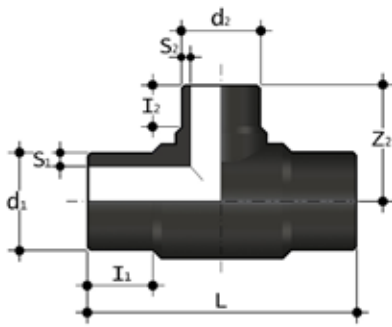

## TRBE SDR 17

90° reducing Tee, short spigot for butt welding SDR 17 - S 8

$d_1$	$d_2$	L	$Z_2$	$I_1$	$I_2$	$S_1$	$S_2$	g	PN10 code SDR 17 - S 8
*140	63	291	120	83	32	8,3	3,8	1.380	TRBE17140063
*140	75	291	130	81	35	8,3	4,5	1.380	TRBE17140075
*140	90	291	130	81	41	8,3	5,4	1.409	TRBE17140090
*140	110	291	140	50	44	8,3	6,6	1.720	TRBE17140110
*160	125	315	150	58	47	9,5	7,4	2.220	TRBE17160125
*180	63	348	140	125	30	10,7	3,8	2.180	TRBE17180063
*180	75	348	160	112	30	10,7	4,5	2.200	TRBE17180075
*180	125	348	150	92	50	10,7	7,4	2.350	TRBE17180125
*225	110	556	236	130	86	13,4	6,6	4.520	TRBE17225110
*225	125	445	180	135	40	13,4	7,4	4.380	TRBE17225125

\*resale products

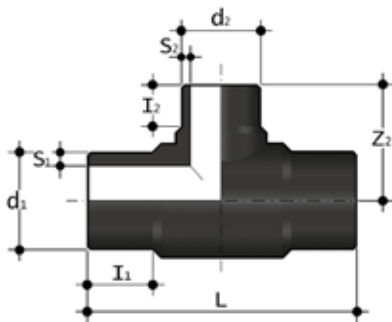

## TRBE SDR 11

90° reducing Tee, short spigot for butt welding SDR 11 - S 5

$d_1$	$d_2$	L	$Z_2$	$I_1$	$I_2$	$S_1$	$S_2$	g	PN16 code SDR 11 - S 5
*90	32	203	85	53	23	8,2	2,9	579	TRBE11090032
*110	32	234	91	66	22	10,0	2,9	963	TRBE11110032
*110	50	240	101	66	27	10,0	4,6	965	TRBE11110050
*125	63	264	110	70	31	11,4	5,8	1.420	TRBE11125063
*140	63	291	120	83	32	12,7	5,8	1.880	TRBE11140063
*140	75	291	130	81	35	12,7	6,8	1.850	TRBE11140075
*140	90	291	130	81	41	12,7	8,2	1.967	TRBE11140090
*140	110	291	140	50	44	12,7	10,0	2.280	TRBE11160110
*160	125	315	150	58	47	14,6	11,4	2.820	TRBE11160125
*180	63	348	140	125	30	16,4	5,8	3.160	TRBE11180063
*180	75	348	160	112	30	16,4	6,8	3.180	TRBE11180075
*180	125	348	150	92	50	16,4	11,4	3.360	TRBE11180125
*225	125	456	178	135	40	20,5	11,4	6.400	TRBE11225125

\*resale products

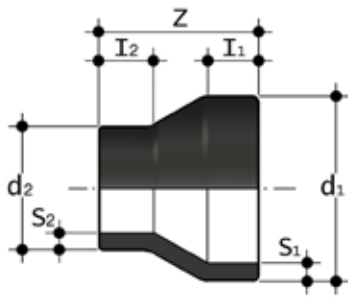

## RBE SDR 17

Concentric reducer, short spigot, for butt welding SDR 17 - S 8

$d_2$	$d_1$	Z	$l_1$	$l_2$	$S_2$	$S_1$	g	PN10 code SDR 17 - S 8
63	40	65	16	12	3,8	2,4	38	RBE17063040
*63	50	87	29	27	3,8	3,0	55	RBE17063050
*75	50	70	30	28	4,5	3,0	70	RBE17075050
75	63	71	19	16	4,5	3,8	62	RBE17075063
*90	50	93	30	28	5,4	3,0	106	RBE17090050
90	63	80	22	16	5,4	3,8	88	RBE17090063
90	75	78	22	19	5,4	4,5	103	RBE17090075
*110	50	93	28	20	6,6	3,0	140	RBE17110050
*110	63	105	40	36	6,6	3,8	180	RBE17110063
110	75	97	28	19	6,6	4,5	110	RBE17110075
110	90	97	28	22	6,6	5,4	90	RBE17110090
125	63	97	35	20	7,4	3,8	279	RBE17125063
*125	75	98	30	20	7,4	4,5	195	RBE17125075
*125	90	114	41	41	7,4	5,4	270	RBE17125090
125	110	108	32	28	7,4	6,6	150	RBE17125110
*140	75	110	35	19	8,3	4,5	360	RBE17140075
140	90	115	35	22	8,3	5,4	170	RBE17140090
140	110	115	35	28	8,3	6,6	140	RBE17140110
140	125	115	35	32	8,3	7,4	150	RBE17140125
*160	90	141	48	34	9,5	5,4	475	RBE17160090
160	110	124	40	28	9,5	6,6	290	RBE17160110
160	125	124	40	32	9,5	7,4	240	RBE17160125
160	140	124	40	35	9,5	8,3	250	RBE17160140
*180	90	145	53	42	10,7	5,4	650	RBE17180090
180	110	157	45	28	10,7	6,6	360	RBE17180110
*180	140	135	51	47	10,7	8,3	670	RBE17180140
*200	160	145	62	52	11,9	9,5	950	RBE17200160
*225	140	157	62	48	13,4	8,3	1.155	RBE17225140
225	160	171	55	40	13,4	9,5	630	RBE17225160
225	180	171	55	45	13,4	10,7	600	RBE17225180
*225	200	149	62	52	13,4	11,9	1.210	RBE17225200
*250	160	174	64	52	14,8	9,5	1.610	RBE17250160
*250	180	175	64	58	14,8	10,7	1.710	RBE17250180
*250	225	180	65	65	14,8	13,4	1.990	RBE17250225
*280	200	214	75	54	16,6	11,9	2.570	RBE17280200
*280	225	200	70	50	16,6	13,4	2.505	RBE17280225
*280	250	200	73	62	16,6	14,8	2.680	RBE17280250
*315	200	199	80	55	18,7	11,9	3.180	RBE17315200
*315	225	237	84	59	18,7	13,4	3.560	RBE17315225
*315	250	234	88	64	18,7	14,8	3.695	RBE17315250
*315	280	227	85	72	18,7	16,6	3.940	RBE17315280
*355	200	155	64	40	21,1	11,9	4.170	RBE17355200
*355	225	140	57	40	21,1	13,4	3.100	RBE17355225
*355	250	130	54	40	21,1	14,8	3.000	RBE17355250
*355	280	120	53	40	21,1	16,6	2.700	RBE17355280
*355	315	110	53	40	21,1	18,7	2.400	RBE17355315
*400	225	160	64	40	23,7	13,4	4.600	RBE17400225

$d_2$	$d_1$	Z	$l_1$	$l_2$	$S_2$	$S_1$	g	PN10 code SDR 17 - S 8
*400	250	150	61	40	23,7	14,8	4.400	RBE17400250
*400	280	140	60	40	23,7	16,6	4.100	RBE17400280
*400	315	120	50	40	23,7	18,7	3.740	RBE17400315
*400	355	110	51	40	23,7	21,1	3.100	RBE17400355
*450	280	160	65	40	26,7	16,6	6.000	RBE17450280
*450	315	140	55	40	26,7	18,7	5.400	RBE17450315
*450	355	130	57	40	26,7	21,1	5.000	RBE17450355
*450	400	120	60	40	26,7	23,7	4.400	RBE17450400
*500	280	195	85	40	29,7	16,6	10.600	RBE17500280
*500	315	170	71	40	29,7	18,7	8.100	RBE17500315
*500	355	150	62	40	29,7	21,1	7.300	RBE17500355
*500	400	140	65	40	29,7	23,7	6.700	RBE17500400
*500	450	120	60	40	29,7	26,7	5.500	RBE17500450
*560	355	185	80	40	33,2	21,1	12.000	RBE17560355
*560	400	160	68	40	33,2	23,7	10.400	RBE17560400
*560	450	140	62	40	33,2	26,7	8.300	RBE17560450
*560	500	130	67	40	33,2	29,7	6.500	RBE17560500
*630	355	225	99	40	37,4	21,1	20.100	RBE17630355
*630	400	190	78	40	37,4	23,7	16.900	RBE17630400
*630	450	170	72	40	37,4	26,7	14.100	RBE17630450
*630	500	150	67	40	37,4	29,7	11.500	RBE17630500
*630	560	130	64	40	37,4	33,2	8.600	RBE17630560
*710	500	195	88	40	42,1	29,7	80.900	RBE17710500
*710	560	165	76	40	42,1	33,2	16.600	RBE17710560
*710	630	130	61	40	42,1	37,4	12.200	RBE17710630
*800	560	210	95	40	47,4	33,2	28.700	RBE17800560
*800	630	175	80	40	47,4	37,4	22.500	RBE17800630
*800	710	135	63	40	47,4	42,1	16.100	RBE17800710
*900	630	230	106	40	53,3	37,4	40.900	RBE17900630
*900	710	190	89	40	53,3	42,1	31.700	RBE17900710
*900	800	145	70	40	53,3	47,4	22.300	RBE17900800
*1000	710	240	110	40	59,3	42,1	52.300	RBE171000710
*1000	800	195	91	40	59,3	47,4	39.700	RBE171000800

\*resale products

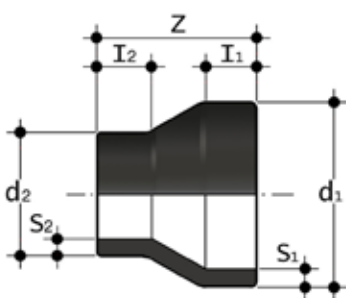

## RBE SDR 11

Concentric reducer, short spigot, for butt welding SDR 11 - S 5

$d_1$	$d_2$	Z	$l_1$	$l_2$	$S_1$	$S_2$	g	PN16 code SDR 11 - S 5
*32	25	68	25	25	2,9	2,3	17	RBE11032025
*40	25	62	20	20	3,7	2,3	21	RBE11040025
*40	32	62	25	25	3,7	3,0	20	RBE11040032
*50	25	85	25	25	4,6	2,3	40	RBE11050025
*50	32	70	20	20	4,6	2,9	40	RBE11050032
*50	40	80	25	25	4,6	3,7	50	RBE11050040
*63	32	65	16	12	5,8	2,9	45	RBE11063032
*63	40	89	35	21	5,8	3,7	75	RBE11063040
*63	50	87	25	25	5,8	4,6	85	RBE11063050

d <sub>1</sub>	d <sub>2</sub>	Z	l <sub>1</sub>	l <sub>2</sub>	S <sub>1</sub>	S <sub>2</sub>	g	PN16 code SDR 11 - S 5
*75	63	82	25	25	6,8	5,8	115	RBE11075063
90	63	80	22	16	8,2	5,8	129	RBE11090063
*90	75	91	30	28	8,2	6,8	180	RBE11090075
110	63	97	28	16	10,0	5,8	160	RBE11110063
*110	75	96	40	28	10,0	6,8	245	RBE11110075
110	90	97	28	22	10,0	8,2	150	RBE11110090
*125	90	110	42	41	11,4	8,2	370	RBE11125090
*125	110	100	40	40	11,4	10,0	395	RBE11125110
*140	90	131	53	42	12,7	8,2	540	RBE11140090
*140	110	120	50	40	12,7	10,0	550	RBE11140110
*140	125	120	51	40	12,7	11,4	580	RBE11140125
*160	90	141	48	34	14,6	8,2	710	RBE11160090
*160	110	130	40	34	14,6	10,0	670	RBE11160110
*160	125	122	40	32	14,6	11,4	720	RBE11160125
*180	110	150	55	42	16,4	10,0	1.020	RBE11180110
*225	160	160	65	53	20,5	14,6	1.810	RBE11225160
*225	200	148	63	53	20,5	18,2	1.805	RBE11225200
*250	160	177	65	53	22,7	14,6	2.330	RBE11250160
*280	200	214	75	54	25,4	18,2	3.780	RBE11280200
*280	225	210	75	58	25,4	20,5	3.860	RBE11280225
*280	250	206	75	60	25,4	22,7	4.155	RBE11280250
*315	225	237	84	57	28,6	20,5	5.480	RBE11315225
*315	250	236	86	64	28,6	22,7	5.300	RBE11315250
*315	280	231	86	72	28,6	25,4	5.600	RBE11315280
*355	200	165	74	40	32,2	18,2	5.280	RBE11355200
*355	225	140	57	40	32,2	20,5	4.700	RBE11355225
*355	250	130	54	40	32,2	22,7	4.400	RBE11355250
*355	280	120	53	40	32,2	25,4	4.100	RBE11355280
*355	315	110	53	40	32,2	28,6	3.700	RBE11355315
*400	225	160	64	40	36,3	20,5	6.800	RBE11400225
*400	250	150	61	40	36,3	22,7	6.500	RBE11400250
*400	280	140	60	40	36,3	25,4	6.200	RBE11400280
*400	315	120	50	40	36,3	28,6	5.300	RBE11400315
*400	355	110	51	40	36,3	32,2	4.800	RBE11400355
*450	280	160	65	40	40,9	25,4	9.000	RBE11450280
*450	315	140	55	40	40,9	28,6	8.000	RBE11450315
*450	355	130	57	40	40,9	32,2	7.400	RBE11450355
*450	400	120	60	40	40,9	36,3	6.600	RBE11450400
*500	315	170	71	40	45,4	28,6	12.000	RBE11500315
*500	355	150	62	40	45,4	32,2	10.800	RBE11500355
*500	400	140	65	40	45,4	36,3	10.000	RBE11500400
*500	450	120	60	40	45,4	40,9	8.300	RBE11500450
*560	355	195	90	40	50,8	32,2	17.300	RBE11560355
*560	400	160	68	40	50,8	36,3	14.700	RBE11560400
*560	450	140	62	40	50,8	40,9	12.000	RBE11560450
*560	500	130	67	40	50,8	45,4	11.400	RBE11560500
*630	355	235	109	40	57,2	32,2	21.700	RBE11630355
*630	400	190	78	40	57,2	36,3	22.300	RBE11630400
*630	450	170	72	40	57,2	40,9	20.200	RBE11630450
*630	500	150	67	40	57,2	45,4	17.800	RBE11630500
*630	560	130	64	40	57,2	50,8	14.800	RBE11630560

\*resale products

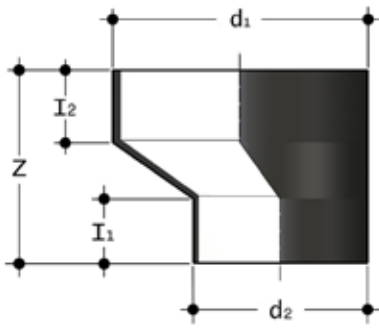

## REBE SDR 17

Eccentric reducer, short spigot, for butt welding SDR 17 - S 8

$d_1$	$d_2$	Z	$I_2$	$I_1$	$S_1$	$S_2$	g	PN10 code SDR 17 - S 8
*160	90	140	54	40	9,5	5,4	700	REBE17160090
*160	110	120	45	40	9,5	6,6	500	REBE17160110
*160	125	110	44	40	9,5	7,4	400	REBE17160125
*160	140	100	43	40	9,5	8,3	340	REBE17160140
*180	110	140	54	40	10,7	6,6	1.100	REBE17180110
*180	125	130	52	40	10,7	7,4	700	REBE17180125
*180	140	120	51	40	10,7	8,3	560	REBE17180140
*180	160	100	43	40	10,7	9,5	320	REBE17180160
*200	140	130	50	40	11,9	8,3	900	REBE17200140
*200	160	120	51	40	11,9	9,5	660	REBE17200160
*200	180	100	43	40	11,9	10,7	540	REBE17200180
*225	160	140	57	40	13,4	9,5	1.200	REBE17225160
*225	180	120	48	40	13,4	10,7	900	REBE17225180
*225	200	100	40	40	13,4	11,9	700	REBE17225200
*250	160	160	62	40	14,8	9,5	2.400	REBE17250160
*250	180	140	54	40	14,8	10,7	1.400	REBE17250180
*250	200	133	55	40	14,8	11,9	1.100	REBE17250200
*250	225	100	40	40	14,8	13,4	800	REBE17250225
*280	200	160	68	40	16,6	11,9	2.500	REBE17280200
*280	225	130	52	40	16,6	13,4	2.050	REBE17280225
*280	250	110	47	40	16,6	14,8	1.700	REBE17280250
*315	225	160	62	40	18,7	13,4	3.800	REBE17315225
*315	250	140	57	40	18,7	14,8	2.100	REBE17315250
*315	280	120	54	40	18,7	16,6	1.400	REBE17315280

\*resale products



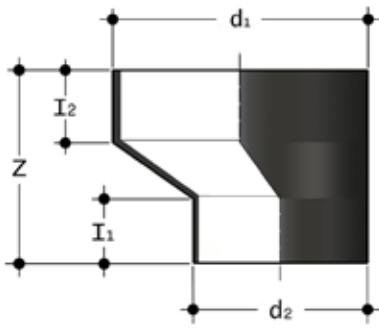

## REBE SDR 11

Eccentric reducer, short spigot, for butt welding SDR 11 - S 5

$d_1$	$d_2$	Z	$I_2$	$I_1$	$S_1$	$S_2$	g	PN16 code SDR 11 - S 5
*160	90	140	54	40	14,6	8,2	2.510	REBE1160090
*160	110	120	45	40	14,6	10,0	780	REBE1160110
*160	125	110	44	40	14,6	11,4	800	REBE1160125
*160	140	100	43	40	14,6	12,7	700	REBE1160140
*180	125	130	52	40	16,4	11,4	1.160	REBE1180125
*180	140	120	51	40	16,4	12,7	1.100	REBE1180140
*180	160	100	43	40	16,4	14,6	900	REBE1180160
*200	125	150	61	40	18,2	11,4	1.800	REBE11200125
*200	140	130	50	40	18,2	12,7	1.400	REBE11200140
*200	160	120	51	40	18,2	14,6	1.320	REBE11200160
*200	180	100	43	40	18,2	16,4	1.070	REBE11200180
*225	160	140	57	40	20,5	14,6	1.960	REBE11225160
*225	180	120	48	40	20,5	16,4	1.600	REBE11225180
*225	200	110	50	40	20,5	18,2	1.500	REBE11225200
*250	160	170	72	40	22,7	14,6	3.300	REBE11250160
*250	180	150	64	40	22,7	16,4	2.700	REBE11250180
*250	200	130	55	40	22,7	18,2	2.260	REBE11250200
*250	225	110	50	40	22,7	20,5	1.860	REBE11250225
*280	180	180	76	40	25,4	16,4	4.400	REBE11280180
*280	200	160	68	40	25,4	18,2	3.680	REBE11280200
*280	225	140	62	40	25,4	20,5	3.100	REBE11280225
*280	250	120	57	40	25,4	22,7	2.600	REBE11280250
*315	200	190	78	40	28,6	18,2	6.300	REBE11315200
*315	225	170	72	40	28,6	20,5	5.000	REBE11315225
*315	250	150	67	40	28,6	22,7	4.300	REBE11315250
*315	280	130	64	40	28,6	25,4	3.660	REBE11315280

\*resale products

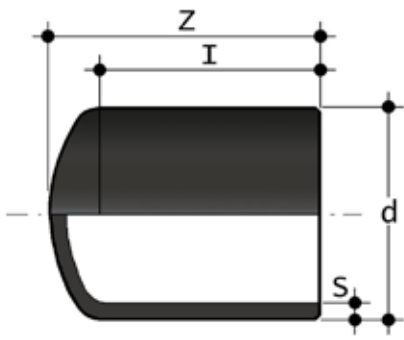

### CBE SDR 17

End cap, short spigot for butt welding SDR 17 – S8

d	Z	I	S	g	PN10 code SDR 17 – S 8
*450	85	20	26,7	10.500	CBE17450
*500	90	18	29,7	14.200	CBE17500
*560	100	19	33,2	20.000	CBE17560
*630	110	19	37,4	28.300	CBE17630
*710	130	26	42,1	33.500	CBE17710
*800	140	23	47,4	47.500	CBE17800

\*resale products  
Per other dimensions refer to CDE

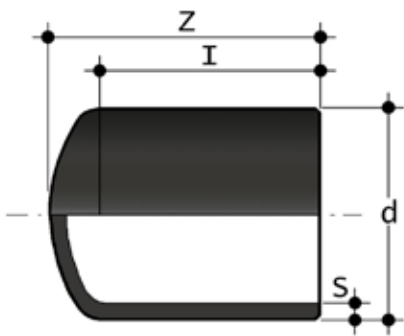

### CBE SDR 11

End cap, short spigot for butt welding SDR 11 – S5

d	Z	I	S	g	PN16 code SDR 11 – S 5
*450	95	17	40,9	12.700	CBE11450
*500	105	19	45,4	17.400	CBE11500
*560	115	19	50,8	24.100	CBE11560
*630	125	17	57,2	33.900	CBE11630

\*resale products  
Per other dimensions refer to CDE

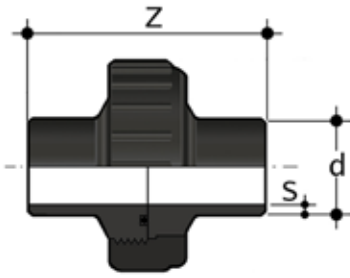

## BBE-C

Complete union, short spigot, for butt welding with EPDM or FKM O-ring SDR 11 - S5

d	Z	S	g	EPDM PN16 code SDR 11 - S 5	FKM PN16 code SDR 11 - S 5
20	110	1,9	60	BBEC11020E	BBEC11020F
25	110	2,3	83	BBEC11025E	BBEC11025F
32	110	2,9	123	BBEC11032E	BBEC11032F
40	110	3,7	214	BBEC11040E	BBEC11040F
50	110	4,6	299	BBEC11050E	BBEC11050F
63	110	5,8	491	BBEC11063E	BBEC11063F
75	110	6,8	599	BBEC11075E*	BBEC11075F*
90	180	8,2	737	BBEC11090E*	BBEC11090F*
110	180	10,0	1154	BBEC11110E*	BBEC11110F*

\*reduced pressure class (PN 10) with PVC nut only

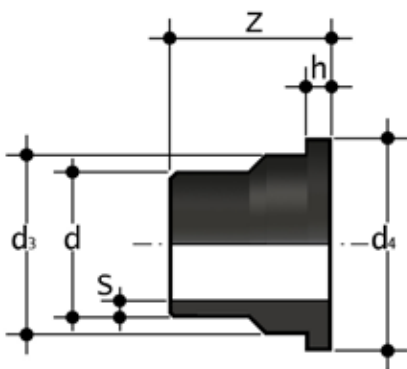

## Q/BBE-C

Union end, short spigot, for butt welding SDR 11 - S5

d	Z	h	d <sub>3</sub>	d <sub>4</sub>	S	g	PN16 code SDR 11 - S 5
20	55	5	27.4	30	1,9	12	QBBEC11020
25	55	6	35.9	38.5	2,3	20	QBBEC11025
32	55	6	41.4	44.5	2,9	25	QBBEC11032
40	55	7	52.8	56.2	3,7	45	QBBEC11040
50	55	7	58.8	62.2	4,6	53	QBBEC11050
63	55	8	73.8	78.3	5,8	89	QBBEC11063

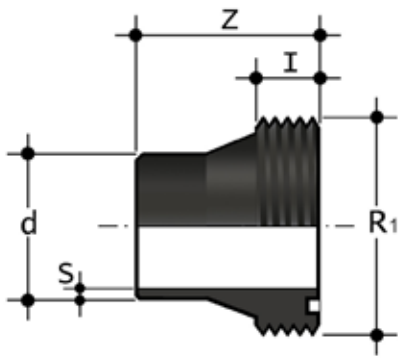

## F/BBE-C

Union bush, short spigot, for butt welding SDR 11 - S5

d	Z	I	R <sub>1</sub>	S	g	PN16 code SDR 11 - S 5
20	55	13	1"	1,9	13	FBBEC11020
25	55	13	1¼"	2,3	29	FBBEC11025
32	55	14	1½"	2,9	42	FBBEC11032
40	55	16	2"	3,7	43	FBBEC11040
50	55	18	2¼"	4,6	90	FBBEC11050
63	55	20	2¾"	5,8	94	FBBEC11063

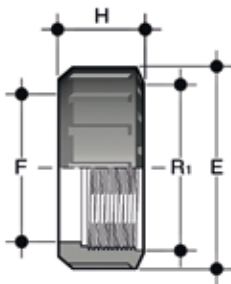

## EFV

Union nut for PE union end

d union	R <sub>1</sub>	H	F	E	g	Code
20	1"	22	28	41	13	EFV100
25	1¼"	25	36	50	22	EFV114
32	1½"	27	42	58	30	EFV112
40	2"	30	53	72	50	EFV200
50	2¼"	34	59	79	68	EFV214
63	2¾"	38	74	98	120	EFV234

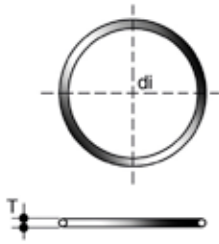

## O-RING

O-ring for PE union bush

$d_e$	$d_i$	$T$	EPDM code	FKM code
20	20,22	3,53	OR4081E	OR4081F
25	28,17	3,53	OR4112E	OR4112F
32	32,93	3,53	OR4131E	OR4131F
40	40,65	5,34	OR6162E	OR6162F
50	47,00	5,34	OR6187E	OR6187F
63	59,69	5,34	OR6237E	OR6237F

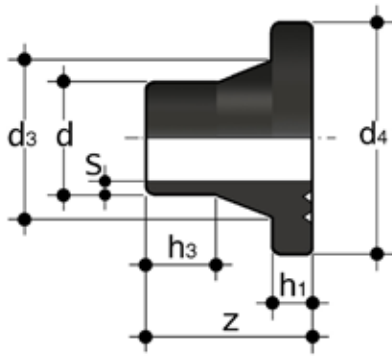

## QBE SDR 33

Stub flange, short spigot, for butt welding for ISO/DIN backing rings SDR 33 -S 16

d	$h_1$	$h_3$	$d_3$	$d_4$	z	S	g	PN5 code SDR 33 - S 16
*110	18	37	125	158	83	3,4	310	QBE33110
*125	18	44	132	158	87	3,9	308	QBE33125
*140	18	35	155	188	83	4,3	420	QBE33140
*160	18	43	175	212	95	4,9	555	QBE33160
*180	18	62	186	212	84	5,5	535	QBE33180
*200	18	60	232	268	121	6,2	1.195	QBE33200
*225	18	65	235	268	121	6,9	960	QBE33225
*250	20	60	285	320	119	7,7	1.765	QBE33250
*280	20	71	291	320	118	8,6	1.375	QBE33280
*315	20	86	335	370	165	9,7	2.490	QBE33315
*355	23	100	373	430	180	10,9	3.590	QBE33355
*400	26	100	427	482	195	12,3	5.440	QBE33400
*450	33	60	514	585	139	13,8	7.470	QBE33450
*500	38	60	530	585	138	15,3	6.560	QBE33500
*560	40	60	615	685	139	17,2	9.840	QBE33560
*630	40	80	642	685	142	19,3	7.520	QBE33630
*710	35	50	737	800	135	21,8	13.060	QBE33710
*800	36	60	840	905	150	24,5	15.000	QBE33800

\*resale products

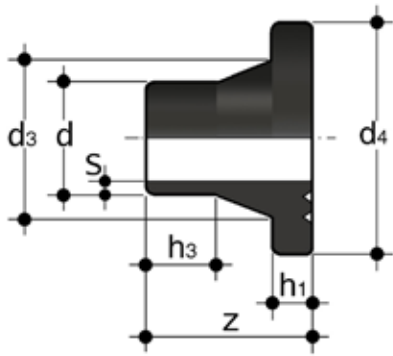

## QBE SDR 17

Stub flange, short spigot, for butt welding for ISO/DIN backing rings SDR 17 - S 8

d	$h_1$	$h_3$	$d_3$	$d_4$	z	S	g	PN10 code SDR 17 - S 8
*50	12	30	61	88	56	3,0	80	QBE17050
63	14	16	75	102	50	3,8	119	QBE17063
75	16	14	89	122	50	4,5	182.4	QBE17075
90	17	33	105	138	80	5,4	292	QBE17090
110	18	27	125	158	80	6,6	390	QBE17110
125	18	42	132	158	80	7,4	383	QBE17125
140	18	34	155	188	80	8,3	536	QBE17140
160	18	34	175	212	80	9,5	699	QBE17160
180	20	60	182	212	80	10,7	651	QBE17180
*200	24	75	233	268	140	11,9	1.490	QBE17200
225	24	46	235	268	100	13,4	1.346	QBE17225
250	25	35	285	320	100	14,8	2.170	QBE17250
280	25	45	291	320	100	16,6	1.950	QBE17280
315	25	35	335	370	100	18,7	2.713	QBE17315
*355	30	100	373	430	180	21,1	5.840	QBE17355
*400	33	105	427	482	195	23,7	7.860	QBE17400
*450	46	60	514	585	139	26,7	10.810	QBE17450
*500	46	60	530	585	138	29,7	9.720	QBE17500
*560	50	60	615	685	139	33,2	14.410	QBE17560
*630	50	60	642	685	142	37,4	12.660	QBE17630
*710	35	50	737	800	135	42,1	20.791	QBE17710
*800	54	60	840	905	150	47,4	20.000	QBE17800

\*resale products

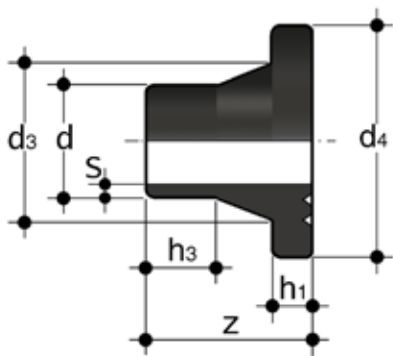

## QBE SDR 11

Stub flange, short spigot, for butt welding for ISO/DIN backing rings SDR 11 -S 5

d	$h_1$	$h_3$	$d_3$	$d_4$	z	S	g	PN16 code SDR 11 - S 5
*32	10	28	40	68	52	2,9	46	QBE11032
*40	11	25	50	78	51	3,7	68	QBE11040
*50	12	30	61	88	56	4,6	92	QBE11050
*63	14	25	75	102	57	5,8	141	QBE11063
75	16	14	89	122	50	6,8	205	QBE11075
*90	17	43	105	138	80	8,2	343	QBE11090
110	18	27	125	158	80	10,0	459	QBE11110
*125	25	40	132	158	90	11,4	518	QBE11125
*140	25	35	155	188	83	12,7	760	QBE11140
*160	25	52	175	212	100	14,6	970	QBE11160
*180	30	65	186	212	127	16,4	976	QBE11180
*200	32	65	232	268	140	18,2	2.019	QBE11200
225	32	38	235	268	100	20,5	1.881	QBE11225
*250	35	55	285	320	120	22,7	3.006	QBE11250
*280	35	69	291	320	119	25,4	2.776	QBE11280
*315	35	86	335	370	168	28,6	3.603	QBE11315
*355	40	100	373	430	187	32,2	8.120	QBE11355
*400	46	95	427	482	195	36,3	11.175	QBE11400
*450	60	60	514	585	139	40,9	14.310	QBE11450
*500	60	60	530	585	138	45,4	13.340	QBE11500
*560	60	70	616	685	195	50,8	25.280	QBE11560
*630	60	80	644	685	210	57,2	26.000	QBE11630
*710	70	60	737	800	153	64,5	32.720	QBE11710

\*resale products



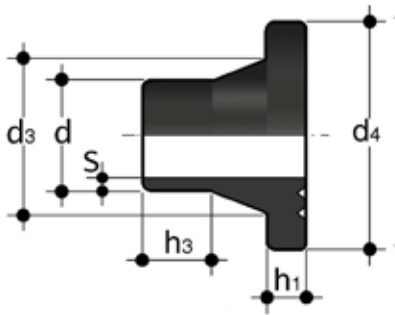

### QBE/FK SDR 17

Machined stub flange, short spigot, for butt welding for FIP butterfly valve type FE and FK SDR 17 - S8

d	DN	$h_1$	$h_3$	$d_3$	$d_4$	S	g	PN10 code SDR 17 - S 8
200	200	24	36	232	268	11,9	1760	QBE17FK200
250	250	25	35	285	320	14,8	1460	QBE17FK250
315	300	25	35	335	370	18,7	3600	QBE17FK315
355	355	30	99	373	430	21,1	5400	QBE17FK355
400	400	33	195	427	482	23,7	7120	QBE17FK400

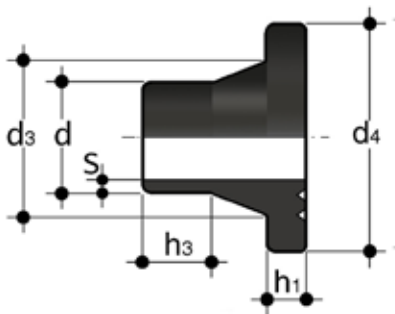

### QBE/FK SDR 11

Machined stub flange, short spigot, for butt welding for FIP butterfly valve type FE and FK SDR 11 - S 5

d	DN	$h_1$	$h_3$	$d_3$	$d_4$	S	g	PN16 code SDR 11 - S 5
160	150	25	34	175	212	14,6	1.120	QBE11FK160
200	200	32	36	232	268	18,2	2.160	QBE11FK200
225	200	32	46	235	268	20,5	2.170	QBE11FK225
250	250	35	35	285	320	22,7	2.920	QBE11FK250
280	250	35	45	291	320	25,4	2.900	QBE11FK280
315	300	35	35	335	370	28,6	5.530	QBE11FK315
355	355	40	90	373	430	32,2	7.730	QBE11FK355
400	400	46	95	427	482	36,3	10.490	QBE11FK400

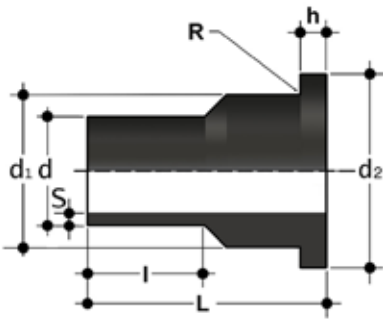

## QBXE SDR 17

Stub flange, short spigot, for butt welding for exit side FIP check valve type CR and FR, SDR 17 – S8

d	DN	h	l	d <sub>1</sub>	d <sub>2</sub>	R	S	L	g	PN10 code SDR 17 – S 8
*50	40	12	20	45	61	3	3,0	50	80	QBXE17050
*63	50	14	20	60	77	4	3,8	54	119	QBXE17063
*75	65	16	20	72	91	4	4,5	65	184	QBXE17075
*90	80	17	35	84	107	4	5,4	95	290	QBXE17090
*110	100	18	35	108	127	4	6,6	100	390	QBXE17110
*125	125	25	35	132	160	4	11,4	100	510	QBXE17125
*140	125	18	35	133	157	4	8,3	110	535	QBXE17140
*160	150	18	35	160	186	3	9,5	125	699	QBXE17160
*180	150	20	40	160	186	3	10,7	120	630	QBXE17180
*200	200	24	40	208	236	4	11,9	180	1480	QBXE17200
*225	200	24	40	208	236	4	13,4	155	1346	QBXE17225
*250	200	25	40	259	292	6	13,4	205	2170	QBXE17250
*280	250	25	40	259	292	6	16,6	185	1860	QBXE17280

\*resale products

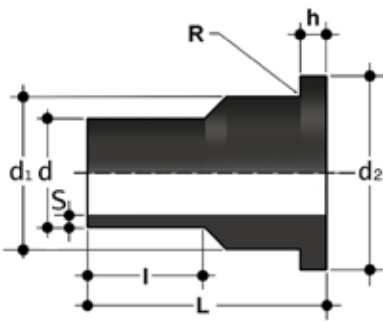

## QBXE SDR 11

Stub flange, short spigot, for butt welding for exit side FIP check valve type CR and FR, SDR 11 - S5

d	DN	h	l	d <sub>1</sub>	d <sub>2</sub>	R	S	L	g	PN16 code SDR 11 - S 5
*50	40	12	20	61	90	3	4,6	50	92	QBXE11050
*63	50	14	20	77	105	4	5,8	60	141	QBXE11063
*75	65	16	20	91	125	4	6,8	75	205	QBXE11075
*90	80	17	35	107	138	4	8,2	100	339	QBXE11090
*110	100	18	35	132	160	4	10,0	108	440	QBXE11110
*125	125	25	35	132	160	4	11,4	100	510	QBXE11125
*140	125	25	35	157	190	4	12,7	120	749	QBXE11140
*160	150	25	35	186	216	4	14,6	125	970	QBXE11160
*180	150	30	40	186	216	4	16,4	120	980	QBXE11180
*200	200	32	40	236	272	4	18,2	190	2020	QBXE11200
*225	200	32	40	236	272	4	20,5	180	1835	QBXE11225
*250	200	35	40	292	328	4	22,7	210	3520	QBXE11250
*280	250	35	40	292	328	6	25,4	200	3550	QBXE11280

\*resale products

# DIMENSIONS

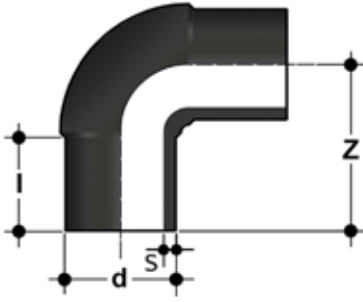

## GDE SDR 17

90° elbow, long spigot for butt welding SDR 17 - S 8

d	Z	l	S	g	PN10 code SDR 17 - S 8
*50	108	80	3,0	105	GDE17050
*63	130	67	3,8	182	GDE17063
*75	153	76	4,5	287	GDE17075
*90	173	83	5,4	465	GDE17090
*110	195	84	6,6	765	GDE17110
*125	216	92	7,4	1.030	GDE17125
*140	237	97	8,3	1.610	GDE17140
*160	262	103	9,5	2.375	GDE17160
*180	290	113	10,7	3.035	GDE17180
*200	317	122	11,9	4.230	GDE17200
*225	350	130	13,4	5.630	GDE17225
*250	382	134	14,8	7.800	GDE17250
*280	430	154	16,6	10.670	GDE17280
*315	465	153	18,7	15.810	GDE17315

\*resale products

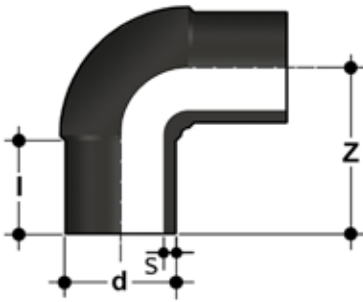

## GDE SDR 11

90° elbow, long spigot for butt welding SDR 11 - S 5

d	Z	l	S	g	PN16 code SDR 11 - S 5
*20	73	52	1,9	21	GDE11020
*25	80	56	2,3	34	GDE11025
*32	79	48	2,9	65	GDE11032
*40	92	52	3,7	97	GDE11040
*50	107	59	4,6	153	GDE11050
*63	131	69	5,8	265	GDE11063
*75	153	76	6,8	415	GDE11075
*90	173	83	8,2	645	GDE11090
*110	195	84	10,0	1.070	GDE11110
*125	216	92	11,4	1.500	GDE11125
*140	237	96	12,7	2.275	GDE11140
*160	262	103	14,6	3.364	GDE11160
*180	294	115	16,4	4.440	GDE11180
*200	317	122	18,2	6.075	GDE11200
*225	351	131	20,5	8.030	GDE11225
*250	382	133	22,7	10.560	GDE11250
*280	432	153	25,4	15.030	GDE11280
*315	471	154	28,6	21.360	GDE11315

\*resale products

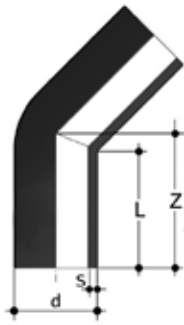

## HDE SDR 17

45° elbow, long spigot for butt welding

d	Z	l	s	g	PN10 code SDR 17 - S 8
*50	76	61	3,0	84	HDE17050
*63	88	65	3,8	145	HDE17063
*75	90	71	4,5	200	HDE17075
*90	105	83	5,4	340	HDE17090
*110	121	91	6,6	575	HDE17110
*125	137	97	7,4	815	HDE17125
*140	168	120	8,3	1.276	HDE17140
*160	190	142	9,5	1.875	HDE17160
*180	196	141	10,7	2.450	HDE17180
*200	207	152	11,9	3.300	HDE17200
*225	210	153	13,4	4.280	HDE17225
*250	220	133	14,8	5.860	HDE17250
*280	227	142	16,6	7.650	HDE17280
*315	250	154	18,7	10.440	HDE17315

\*resale products

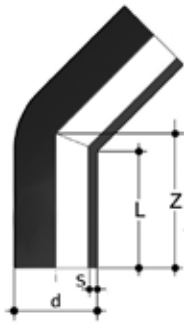

## HDE SDR 11

45° elbow, long spigot for butt welding

d	Z	l	S	g	PN16 code SDR 11 - S 5
*20	72	52	1,9	20	HDE11020
*25	75	57	2,3	31	HDE11025
*32	90	71	2,9	58	HDE11032
*40	95	74	3,7	91	HDE11040
*50	76	62	4,6	111	HDE11050
*63	88	66	5,8	210	HDE11063
*75	90	71	6,8	291	HDE11075
*90	105	83	8,2	480	HDE11090
*110	121	93	10,0	850	HDE11110
*125	137	99	11,4	1.200	HDE11125
*140	168	121	12,7	1.760	HDE11140
*160	190	142	14,6	2.723	HDE11160
*180	196	141	16,4	3.470	HDE11180
*200	207	153	18,2	4.610	HDE11200
*225	210	154	20,5	6.145	HDE11225
*250	220	133	22,7	8.330	HDE11250
*280	227	144	25,4	10.640	HDE11280
*315	250	155	28,6	14.670	HDE11315

\*resale products

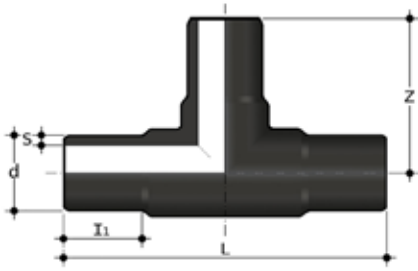

## TDE SDR 17

90° Tee, long spigot for butt welding SDR 17 - S8

d	L	Z	l <sub>1</sub>	S	g	PN10 code SDR 17 - S 8
*50	184	90	57	3,0	130	TDE17050
*63	214	106	64	3,8	238	TDE17063
*75	246	122	72	4,5	395	TDE17075
*90	277	137	81	5,4	690	TDE17090
*110	321	161	84	6,6	1.120	TDE17110
*125	345	174	100	7,4	1.564	TDE17125
*140	395	197	104	8,3	2.215	TDE17140
*160	410	206	104	9,5	3.010	TDE17160
*180	525	260	141	10,7	4.875	TDE17180
*200	501	250	123	11,9	5.695	TDE17200
*225	555	276	129	13,4	8.260	TDE17225
*250	576	288	132	14,8	9.380	TDE17250
*280	617	309	132	16,6	12.980	TDE17280
*315	695	346	153	18,7	17.650	TDE17315
*355	818	408	165	21,1	25.975	TDE17355
*400	910	455	197	23,7	36.060	TDE17400
*450	955	478	197	26,7	50.615	TDE17450
*500	1050	525	218	29,7	68.400	TDE17500
*560	1200	600	245	33,2	139.000	TDE17560
*630	1300	650	265	37,4	185.000	TDE17630

\*resale products



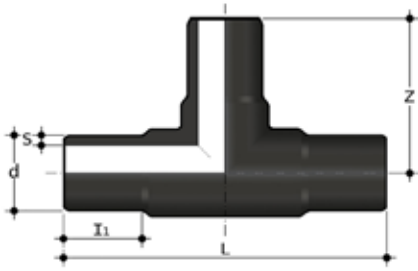

## TDE SDR 11

90° Tee, long spigot for butt welding SDR 11 - S5

d	L	Z	l <sub>1</sub>	S	g	PN16 code SDR 11 - S 5
*20	108	54	41	1,9	20	TDE11020
*25	120	60	41	2,3	33	TDE11025
*32	139	67	46	2,9	60	TDE11032
*40	165	82	52	3,7	112	TDE11040
*50	184	92	57	4,6	187	TDE11050
*63	216	105	65	5,8	335	TDE11063
*75	248	122	72	6,8	545	TDE11075
*90	277	137	80	8,2	940	TDE11090
*110	321	162	88	10,0	1.579	TDE11110
*125	350	176	98	11,4	2.240	TDE11125
*140	399	200	104	12,7	3.180	TDE11140
*160	413	206	104	14,6	4.290	TDE11160
*180	528	260	143	16,4	6.890	TDE11180
*200	505	253	124	18,2	8.330	TDE11200
*225	559	278	129	20,5	11.700	TDE11225
*250	582	291	132	22,7	13.950	TDE11250
*280	622	312	133	25,4	18.860	TDE11280
*315	690	351	153	28,6	26.370	TDE11315
*355	818	408	165	32,2	38.100	TDE11355
*400	913	457	198	36,3	52.010	TDE11400
*450	954	477	198	40,9	74.585	TDE11450
*500	1050	525	218	45,4	100.000	TDE11500
*560	1200	600	245	50,8	142.000	TDE11560
*630	1300	650	265	57,2	188.000	TDE11630

\*resale products

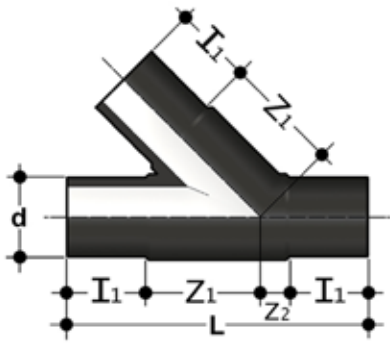

### T45DE SDR 17

45° Tee, long spigot for butt welding SDR 17 - S8

d	L	I <sub>1</sub>	Z <sub>1</sub>	Z <sub>2</sub>	S	g	PN10 code SDR 17 - S 8
*50	223	55	90	23	3,0	200	T45DE17050
*63	256	70	68	24	3,8	410	T45DE17063
*75	299	77	113	32	4,5	690	T45DE17075
*90	354	82	148	42	5,4	1.080	T45DE17090
*110	399	90	170	49	6,6	1.640	T45DE17110
*125	440	93	204	47	7,4	2.665	T45DE17125
*160	521	98	262	68	9,5	4.820	T45DE17160
*180	557	105	275	74	10,7	6.440	T45DE17180
*200	598	113	294	78	11,9	8.420	T45DE17200
*225	670	120	344	86	13,4	11.980	T45DE17225

\*resale products

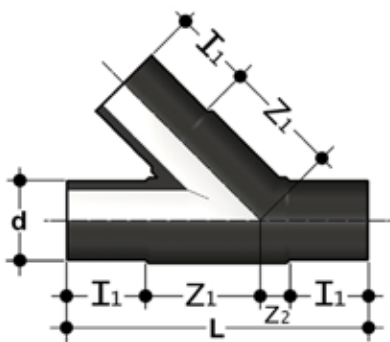

### T45DE SDR 11

45° Tee, long spigot for butt welding SDR 11 - S5

d	L	I <sub>1</sub>	Z <sub>1</sub>	Z <sub>2</sub>	S	g	PN16 code SDR 11 - S 5
*63	259	69	93	28	5,8	470	T45DE11063
*75	299	77	113	32	6,8	780	T45DE11075
*90	351	82	148	40	8,2	1.385	T45DE11090
*110	382	84	169	47	10,0	2.190	T45DE11110
*125	431	92	207	48	11,4	3.280	T45DE11125
*160	526	100	262	66	14,6	6.520	T45DE11160
*180	562	107	278	72	16,4	8.600	T45DE11180
*200	605	114	302	77	18,2	11.240	T45DE11200
*225	673	122	352	84	20,5	16.060	T45DE11225

\*resale products

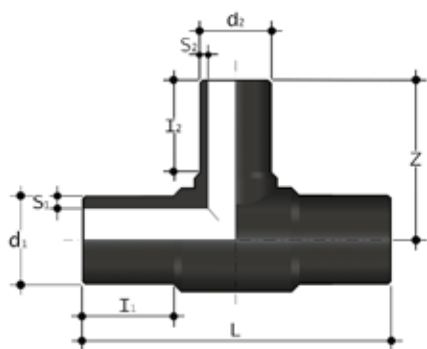

## TRDE SDR 17

90° reduced tee, long spigot for butt welding SDR 17 - S8

$d_1$	$d_2$	L	Z	$I_1$	$I_2$	$S_1$	$S_2$	g	PN10 code SDR 17 - S 8
*63	50	213	100	63	56	3,8	3,0	227	TRDE17063050
*75	50	253	113	70	55	4,5	3,0	400	TRDE17075050
*75	63	252	116	69	62	4,5	3,8	450	TRDE17075063
*90	50	278	118	80	59	5,4	3,0	600	TRDE17090050
*90	63	272	139	81	65	5,4	3,8	610	TRDE17090063
*90	75	272	139	74	71	5,4	4,5	681	TRDE17090075
*110	63	320	147	88	67	6,6	3,8	1.010	TRDE17110063
*110	75	315	152	84	70	6,6	4,5	880	TRDE17110075
*110	90	318	160	86	81	6,6	5,4	1.055	TRDE17110090
*125	63	366	157	101	70	7,4	3,8	1.420	TRDE17125063
*125	110	334	168	84	83	7,4	6,6	1.320	TRDE17125110
*160	63	411	172	103	65	9,5	3,8	2.525	TRDE17160063
*160	75	343	180	98	74	9,5	4,5	2.640	TRDE17160075
*160	90	412	190	104	82	9,5	5,4	2.610	TRDE17160090
*160	110	412	198	103	88	9,5	6,6	2.695	TRDE17160110
*180	90	484	200	110	82	10,7	5,4	2.780	TRDE17180090
*180	110	486	205	110	86	10,7	6,6	4.320	TRDE17180110
*180	160	411	205	105	94	10,7	9,5	3.540	TRDE17180160
*200	63	550	225	134	80	11,9	3,8	5.220	TRDE17200063
*200	90	504	216	125	82	11,9	5,4	5.015	TRDE17200090
*200	110	506	219	124	85	11,9	6,6	5.155	TRDE17200110
*200	160	500	235	120	101	11,9	9,5	5.430	TRDE17200160
*225	75	440	226	120	75	13,4	4,5	4.980	TRDE17225075
*225	90	555	226	129	82	13,4	5,4	7.010	TRDE17225090
*225	110	556	236	130	86	13,4	6,6	7.150	TRDE17225110
*225	160	555	255	128	107	13,4	9,5	7.220	TRDE17225160
*225	180	558	284	128	107	13,4	10,7	7.795	TRDE17225180
*250	110	580	242	133	85	14,8	6,6	8.095	TRDE17250110
*250	160	580	261	133	101	14,8	9,5	8.700	TRDE17250160
*250	200	625	290	148	116	14,8	11,9	11.060	TRDE17250200
*315	110	699	277	155	84	18,7	6,6	15.860	TRDE17315110
*315	160	695	300	153	102	18,7	9,5	15.585	TRDE17315160
*315	200	690	313	155	117	18,7	11,9	17.910	TRDE17315200
*315	225	690	320	155	125	18,7	13,4	16.040	TRDE17315225
*315	250	695	329	154	135	18,7	14,8	16.600	TRDE17315250

\*resale products

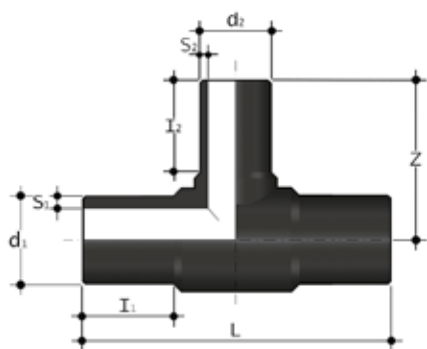

## TRDE SDR 11

90° reduced tee, long spigot for butt welding SDR 11 - S5

d <sub>1</sub>	d <sub>2</sub>	L	Z	l <sub>1</sub>	l <sub>2</sub>	S <sub>1</sub>	S <sub>2</sub>	g	PN16 code SDR 11 - S5
*63	50	215	103	63	56	5,8	4,6	313	TRDE11063050
*75	32	256	108	70	46	6,8	2,9	455	TRDE11075032
*75	50	253	113	70	56	6,8	4,6	485	TRDE11075050
*75	63	255	117	70	63	6,8	5,8	520	TRDE11075063
*90	63	282	127	81	65	8,2	5,8	840	TRDE11090063
*90	75	272	138	73	68	8,2	6,8	800	TRDE11090075
*110	63	322	148	88	67	10,0	5,8	1.400	TRDE11110063
*110	75	309	151	82	70	10,0	6,8	1.425	TRDE11110075
*110	90	322	164	88	82	10,0	8,2	1.495	TRDE11110090
*125	75	350	170	110	75	11,4	6,8	1.820	TRDE11125075
*125	90	332	168	109	89	11,4	8,2	1.700	TRDE11125090
*125	110	341	170	90	83	11,4	10,0	1.860	TRDE11125110
*160	63	416	174	105	65	14,6	5,8	3.605	TRDE11160063
*160	75	343	180	98	74	14,6	6,8	2.300	TRDE11160075
*160	90	415	190	104	83	14,6	8,2	3.690	TRDE11160090
*160	110	414	200	104	89	14,6	10,0	3.865	TRDE11160110
*180	90	476	200	108	82	16,4	8,2	4.857	TRDE11180090
*180	110	480	202	107	84	16,4	10,0	4.750	TRDE11180110
*180	160	480	220	110	101	16,4	14,6	5.560	TRDE11180160
*200	63	553	226	134	82	18,2	5,8	7.140	TRDE11200063
*200	90	500	216	124	82	18,2	8,2	6.895	TRDE11200090
*200	110	505	219	124	86	18,2	10,0	7.060	TRDE11200110
*200	160	500	237	120	101	18,2	14,6	7.445	TRDE11200160
*225	75	560	219	129	73	20,5	6,8	9.750	TRDE11225075
*225	90	555	228	129	82	20,5	8,2	9.850	TRDE11225090
*225	110	559	238	130	86	20,5	10,0	10.100	TRDE11225110
*225	160	556	258	128	107	20,5	14,6	10.485	TRDE11225160
*225	180	559	284	130	108	20,5	16,4	10.915	TRDE11225180
*250	110	584	248	133	85	22,7	10,0	11.685	TRDE11250110
*250	160	586	266	134	102	22,7	14,6	12.180	TRDE11250160
*315	110	706	282	155	85	28,6	10,0	22.150	TRDE11315110
*315	160	705	301	155	101	28,6	14,6	22.730	TRDE11315160
*315	200	680	313	155	117	28,6	18,2	18.710	TRDE11315200
*315	225	680	320	153	125	28,6	20,5	20.160	TRDE11315225
*315	250	695	331	154	135	28,6	22,7	24.345	TRDE11315250

\*resale products

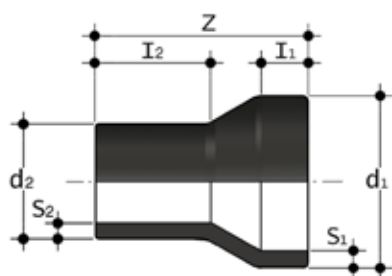

## RDE SDR 17

Concentric reducer, long spigot for butt welding SDR 17 - S8

$d_1$	$d_2$	Z	$l_1$	$l_2$	$S_1$	$S_2$	g	PN10 code SDR 17 - S 8
*63	50	152	64	58	3,8	3,0	95	RDE17063050
*75	63	166	70	63	4,5	3,8	150	RDE17075063
*90	63	182	79	63	5,4	3,8	215	RDE17090063
*90	75	185	80	63	5,4	4,5	236	RDE17090075
*110	63	185	84	69	6,6	3,8	295	RDE17110063
*110	75	183	83	73	6,6	4,5	315	RDE17110075
*110	90	185	83	80	6,6	5,4	335	RDE17110090
*125	63	200	90	68	7,4	3,8	450	RDE17125063
*125	90	200	90	81	7,4	5,4	460	RDE17125090
*125	110	200	91	90	7,4	6,6	500	RDE17125110
*140	90	235	112	86	8,3	5,4	630	RDE17140090
*140	110	237	114	91	8,3	6,6	695	RDE17140110
*140	125	235	117	96	8,3	7,4	740	RDE17140125
*160	90	254	109	84	9,5	5,4	820	RDE17160090
*160	110	254	110	89	9,5	6,6	890	RDE17160110
*160	125	254	110	95	9,5	7,4	960	RDE17160125
*160	140	254	110	106	9,5	8,3	1.010	RDE17160140
*180	125	250	105	87	10,7	7,4	1.145	RDE17180125
*180	140	277	123	114	10,7	8,3	1.305	RDE17180140
*180	160	279	126	125	10,7	9,5	1.450	RDE17180160
*200	140	279	123	114	11,9	8,3	1.590	RDE17200140
*200	160	278	122	124	11,9	9,5	1.655	RDE17200160
*225	140	290	133	114	13,4	8,3	1.980	RDE17225140
*225	160	295	134	123	13,4	9,5	2.175	RDE17225160
*225	180	275	125	118	13,4	10,7	2.145	RDE17225180
*250	160	308	151	98	14,8	9,5	2.850	RDE17250160
*250	180	316	153	105	14,8	10,7	2.850	RDE17250180
*250	200	325	154	113	14,8	11,9	3.205	RDE17250200
*250	225	330	155	122	14,8	13,4	3.550	RDE17250225
*280	200	330	142	116	16,6	11,9	3.880	RDE17280200
*280	225	335	140	124	16,6	13,4	4.100	RDE17280225
*280	250	340	139	134	16,6	14,8	4.420	RDE17280250
*315	200	380	180	134	18,7	11,9	5.400	RDE17315200
*315	225	371	152	125	18,7	13,4	5.290	RDE17315225
*315	250	367	151	133	18,7	14,8	5.635	RDE17315250
*315	280	369	150	140	18,7	16,6	5.950	RDE17315280
*355	250	390	164	129	21,1	14,8	7.200	RDE17355250
*355	280	390	164	139	21,1	16,6	9.000	RDE17355280
*355	315	340	164	150	21,1	18,7	10.000	RDE17355315
*400	280	415	179	139	23,7	16,6	13.500	RDE17400280
*400	315	415	179	150	23,7	18,7	13.060	RDE17400315
*400	355	420	179	164	23,7	21,1	15.000	RDE17400355
*450	315	390	195	150	26,7	18,7	11.600	RDE17450315
*450	355	395	195	165	26,7	21,1	11.900	RDE17450355
*450	400	400	205	180	26,7	23,7	12.700	RDE17450400
*500	315	425	212	150	29,7	18,7	15.500	RDE17500315
*500	355	430	225	165	29,7	21,1	15.700	RDE17500355

$d_1$	$d_2$	Z	$l_1$	$l_2$	$S_1$	$S_2$	g	PN10 code SDR 17 - S 8
*500	400	430	225	180	29,7	23,7	16.200	RDE17500400
*500	450	430	225	195	29,7	26,7	17.000	RDE17500450
*560	355	460	240	165	33,2	21,1	21.400	RDE17560355
*560	400	470	240	180	33,2	23,7	21.700	RDE17560400
*560	450	470	240	195	33,2	26,7	22.300	RDE17560450
*560	500	470	240	215	33,2	29,7	23.200	RDE17560500
*630	400	510	260	180	37,4	23,7	29.700	RDE17630400
*630	450	510	260	195	37,4	26,7	30.100	RDE17630450
*630	500	510	260	215	37,4	29,7	30.800	RDE17630500
*630	560	520	260	235	37,4	33,2	31.900	RDE17630560

\*resale products

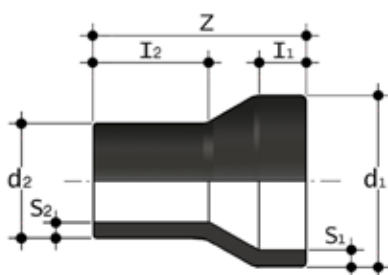

## RDE SDR 11

Concentric reducer, long spigot for butt welding SDR 11 - S 5

$d_1$	$d_2$	Z	$l_1$	$l_2$	$S_1$	$S_2$	g	PN16 code SDR 11 - S 5
*25	20	90	41	41	2,3	1,9	13	RDE11025020
*32	20	101	44	41	2,9	1,9	20	RDE11032020
*32	25	100	44	41	2,9	2,3	23	RDE11032025
*40	20	102	49	41	3,7	1,9	32	RDE11040020
*40	25	104	49	41	3,7	2,3	35	RDE11040025
*40	32	105	49	44	3,7	2,9	39	RDE11040032
*50	25	132	56	42	4,6	2,3	60	RDE11050025
*50	32	132	57	47	4,6	2,9	65	RDE11050032
*50	40	134	55	51	4,6	3,7	75	RDE11050040
*63	32	144	63	44	5,8	2,9	110	RDE11063032
*63	40	147	63	49	5,8	3,7	118	RDE11063040
*63	50	152	64	58	5,8	4,6	130	RDE11063050
*75	50	155	70	55	6,8	4,6	190	RDE11075050
*75	63	171	70	65	6,8	5,8	215	RDE11075063
*90	50	174	79	57	8,2	4,6	280	RDE11090050
*90	63	182	79	70	8,2	5,8	318	RDE11090063
*90	75	180	79	70	8,2	6,8	345	RDE11090075
*110	63	185	84	69	10,0	5,8	435	RDE11110063
*110	75	185	84	74	10,0	6,8	480	RDE11110075
*110	90	186	84	81	10,0	8,2	500	RDE11110090
*125	63	200	91	69	11,4	5,8	635	RDE11125063
*125	90	202	91	80	11,4	8,2	660	RDE11125090
*125	110	200	90	90	11,4	10,0	760	RDE11125110
*140	90	237	112	86	12,7	8,2	940	RDE11140090
*140	110	230	116	90	12,7	10,0	1.035	RDE11140110
*140	125	235	117	96	12,7	11,4	1.120	RDE11140125
*160	90	254	109	84	14,6	8,2	1.280	RDE11160090
*160	110	254	110	89	14,6	10,0	1.335	RDE11160110
*160	125	254	110	95	14,6	11,4	1.420	RDE11160125
*160	140	254	110	106	14,6	12,7	1.595	RDE11160140
*180	125	245	105	87	16,4	11,4	1.725	RDE11180125
*180	160	279	126	125	16,4	14,6	2.100	RDE11180160

d <sub>1</sub>	d <sub>2</sub>	Z	l <sub>1</sub>	l <sub>2</sub>	S <sub>1</sub>	S <sub>2</sub>	g	PN16 code SDR 11 - S 5
*200	160	277	122	122	18,2	14,6	2.420	RDE11200160
*225	160	295	132	123	20,5	14,6	3.075	RDE11225160
*225	180	285	130	118	20,5	16,4	3.215	RDE11225180
*250	160	308	149	100	22,7	14,6	4.070	RDE11250160
*250	180	316	151	105	22,7	16,4	4.270	RDE11250180
*250	200	324	151	116	22,7	18,2	4.675	RDE11250200
*250	225	330	155	122	22,7	20,5	5.280	RDE11250225
*280	200	345	140	116	25,4	18,2	5.850	RDE11280200
*280	225	335	142	122	25,4	20,5	6.090	RDE11280225
*280	250	340	139	135	25,4	22,7	6.700	RDE11280250
*315	200	380	180	134	28,6	18,2	7.640	RDE11315200
*315	225	365	150	125	28,6	20,5	7.960	RDE11315225
*315	250	365	150	134	28,6	22,7	8.470	RDE11315250
*315	280	365	150	145	28,6	25,4	8.915	RDE11315280
*355	250	390	164	136	32,2	22,7	13.520	RDE11355250
*355	280	390	164	139	32,2	25,4	13.155	RDE11355280
*355	315	390	164	150	32,2	28,6	13.000	RDE11355315
*400	280	415	179	139	36,3	25,4	16.880	RDE11400280
*400	315	415	179	150	36,3	28,6	17.700	RDE11400315
*400	355	420	179	164	36,3	32,2	17.800	RDE11400355
*450	280	390	205	140	40,9	25,4	16.200	RDE11450280
*450	315	390	205	150	40,9	28,6	16.700	RDE11450315
*450	355	400	205	165	40,9	32,2	17.500	RDE11450355
*450	400	400	205	180	40,9	36,3	18.500	RDE11450400
*500	315	430	225	150	45,4	28,6	21.900	RDE11500315
*500	355	430	225	165	45,4	32,2	22.600	RDE11500355
*500	400	430	225	180	45,4	36,3	23.600	RDE11500400
*500	450	430	225	195	45,4	40,9	25.100	RDE11500450
*560	355	460	240	165	50,8	32,2	30.100	RDE11560355
*560	400	470	240	180	50,8	36,3	31.000	RDE11560400
*560	450	470	240	195	50,8	40,9	32.400	RDE11560450
*560	500	470	240	215	50,8	45,4	34.100	RDE11560500
*630	400	510	260	180	57,2	36,3	41.900	RDE11630400
*630	450	510	260	195	57,2	40,9	43.100	RDE11630450
*630	500	510	260	215	57,2	45,4	44.700	RDE11630500
*630	560	520	260	235	57,2	50,8	46.800	RDE11630560

\*resale products

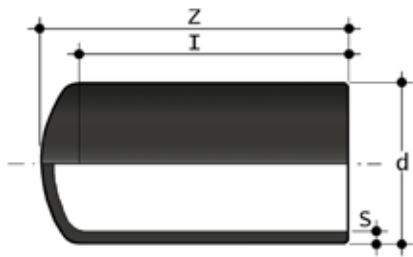

## CDE SDR 17

End cap, long spigot for butt welding SDR 17 - S8

d	Z	I	S	g	PN10 code SDR 17 - S 8
*50	70	59	3,0	34	CDE17050
*125	127	92	7,4	360	CDE17125
*140	136	97	8,3	480	CDE17140
*160	155	107	9,5	740	CDE17160
*180	166	114	10,7	975	CDE17180
*200	179	117	11,9	1.310	CDE17200
*225	203	127	13,4	1.805	CDE17225
*250	216	140	14,8	2.425	CDE17250
*280	238	149	16,6	3.285	CDE17280
*315	258	158	18,7	4.610	CDE17315
*355	281	175	21,1	6.610	CDE17355
*400	310	195	23,7	9.185	CDE17400

\*resale products



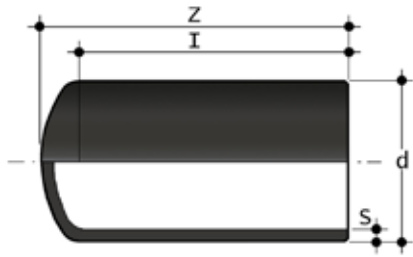

## CDE SDR 11

End cap, long spigot for butt welding SDR 11 – S5

d	Z	I	S	g	PN16 code SDR 11 – S 5
*25	50	41	2,3	9	CDE11025
*32	56	46	2,9	15	CDE11032
*40	61	49	3,7	27	CDE11040
*50	71	58	4,6	47	CDE11050
*63	84	66	5,8	84	CDE11063
*75	94	73	6,8	134	CDE11075
*90	109	82	8,2	234	CDE11090
*110	122	88	10,0	406	CDE11110
*125	128	93	11,4	530	CDE11125
*140	136	97	12,7	715	CDE11140
*160	156	108	14,6	1.085	CDE11160
*180	167	113	16,4	1.430	CDE11180
*200	180	117	18,2	1.930	CDE11200
*225	203	127	20,5	2.730	CDE11225
*250	217	138	22,7	3.645	CDE11250
*280	239	151	25,4	4.975	CDE11280
*315	256	158	28,6	6.865	CDE11315
*355	291	175	32,2	9.710	CDE11355
*400	316	193	36,3	13.530	CDE11400

\*resale products

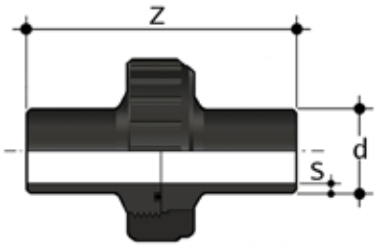

## BBE-L SDR 11

Complete union, longspigot, for butt welding with EPDM or FKM O-ring SDR 11 - S5

d	Z	S	g	*EPDM PN16 code SDR 11 - S 5	*FKM PN16 code SDR 11 - S 5
20	190	1,9	68	BBEL11020E	BBEL11020F
25	190	2,3	107	BBEL11025E	BBEL11025F
32	190	2,9	140	BBEL11032E	BBEL11032F
40	190	3,7	214	BBEL11040E	BBEL11040F
50	190	4,6	299	BBEL11050E	BBEL11050F
63	190	5,8	491	BBEL11063E	BBEL11063F

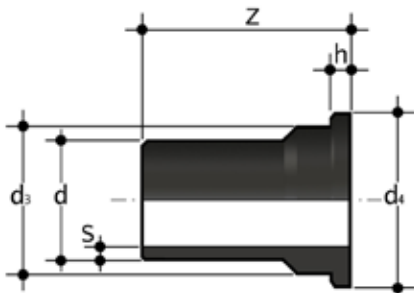

## Q/BBE-L

Union end, long spigot, for butt welding SDR 11 - S5

d	L	h	d <sub>3</sub>	d <sub>4</sub>	S	g	PN16 code SDR 11 - S 5
20	94	5	27,30	29,90	1,9	22	QBBEL11020
25	95	6	35,80	38,60	2,3	38	QBBEL11025
32	95	6	41,20	44,50	2,9	44	QBBEL11032
40	95	7	52,60	56,20	3,7	73	QBBEL11040
50	95	7	58,60	62,30	4,6	107	QBBEL11050
63	95	8	73,60	78,10	5,8	165	QBBEL11063

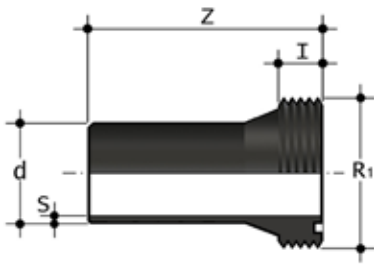

## F/BBE-L

Union bush, long spigot, for butt welding SDR 11 – S5

d	Z	I	R <sub>1</sub>	S	g	PN16 code SDR 11 – S 5
20	95	13	1"	1,9	24	FBBEL11020
25	95	13	1¼"	2,3	40	FBBEL11025
32	95	14	1½"	2,9	54	FBBEL11032
40	95	16	2"	3,7	60	FBBEL11040
50	95	18	2¼"	4,6	116	FBBEL11050
63	95	20	2¾"	5,8	188	FBBEL11063

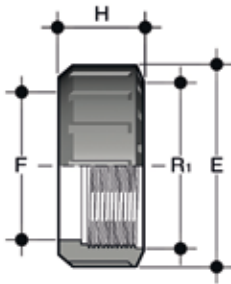

## EFV

Union nut for PE union end

d union	R <sub>1</sub>	H	F	E	g	Code
20	1"	22	28	41	13	EFV100
25	1¼"	25	36	50	22	EFV114
32	1½"	27	42	58	30	EFV112
40	2"	30	53	72	50	EFV200
50	2¼"	34	59	79	68	EFV214
63	2¾"	38	74	98	120	EFV234

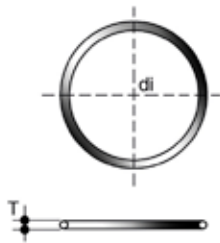

## O-RING

O-ring for PE union bush

$d_e$	$d_i$	T	EPDM code	FKM code
20	20,22	3,53	OR4081E	OR4081F
25	28,17	3,53	OR4112E	OR4112F
32	32,93	3,53	OR4131E	OR4131F
40	40,65	5,34	OR6162E	OR6162F
50	47	5,34	OR6187E	OR6187F
63	59,69	5,34	OR6237E	OR6237F

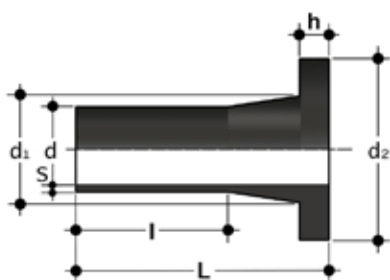

## QDE SDR 17

Stub flange, long spigot, for butt welding for ISO/DIN backing rings SDR 17 -S 8

d	h	I	d <sub>1</sub>	d <sub>2</sub>	L	S	g	PN10 code SDR 17 - S 8
*50	12	62	60	88	90	3,0	106	QDE17050
*63	14	70	75	102	106	3,8	173	QDE17063
*75	16	90	89	122	125	4,5	260	QDE17075
*90	17	100	105	138	140	5,4	379	QDE17090
*110	18	113	125	158	158	6,6	575	QDE17110
*125	18	122	132	158	170	7,4	675	QDE17125
*140	18	130	153	188	173	8,3	860	QDE17140
*160	18	160	175	212	208	9,5	1.320	QDE17160
*180	20	140	186	212	200	10,7	1.300	QDE17180
*200	24	133	232	268	199	11,9	2.170	QDE17200
*225	24	135	235	268	201	13,4	2.260	QDE17225
*250	25	148	285	320	220	14,8	3.620	QDE17250
*280	25	154	291	320	230	16,6	3.810	QDE17280
*315	25	166	335	370	242	18,7	5.230	QDE17315
*355	30	179	373	430	261	21,1	7.420	QDE17355
*400	33	195	427	482	290	23,7	10.460	QDE17400
*450	46	225	515	585	335	26,7	18.670	QDE17450
*500	46	240	532	585	350	29,7	19.780	QDE17500
*560	50	250	616	685	370	33,2	26.940	QDE17560
*630	50	270	644	685	390	37,4	30.360	QDE17630
*710	50	280	737	800	380	42,1	46.000	QDE17710
*800	52	294	840	905	396	47,4	70.000	QDE17800

\*resale products

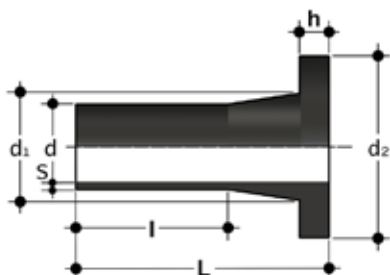

## QDE SDR 11

Stub flange, long spigot, for butt welding for ISO/DIN backing rings SDR 11 -S 5

d	h	l	d <sub>1</sub>	d <sub>2</sub>	L	S	g	PN16 code SDR 11 - S 5
*20	7	62	27	45	85	1,9	21	QDE11020
*25	9	62	33	58	90	2,3	39	QDE11025
*32	10	62	40	68	86	2,9	56	QDE11032
*40	11	62	50	78	89	3,7	87	QDE11040
*50	12	62	60	88	90	4,6	132	QDE11050
*63	14	70	75	102	106	5,8	202	QDE11063
*75	16	90	89	122	125	6,8	315	QDE11075
*90	17	100	105	138	140	8,2	470	QDE11090
*110	18	113	125	158	160	10,0	715	QDE11110
*125	25	116	132	158	170	11,4	902	QDE11125
*140	25	128	155	188	182	12,7	1.280	QDE11140
*160	25	155	175	212	208	14,6	1.835	QDE11160
*180	30	168	182	212	202	16,4	1.960	QDE11180
*200	32	140	232	268	206	18,2	3.130	QDE11200
*225	32	135	235	268	201	20,5	3.260	QDE11225
*250	35	138	285	320	219	22,7	5.180	QDE11250
*280	35	152	291	320	231	25,4	5.590	QDE11280
*315	35	158	335	370	239	28,6	7.575	QDE11315
*355	40	176	373	430	260	32,2	10.740	QDE11355
*400	46	195	427	482	290	36,3	15.335	QDE11400
*450	60	210	516	585	335	40,9	25.690	QDE11450
*500	60	230	532	585	350	45,4	28.200	QDE11500
*560	60	240	616	685	370	50,8	39.260	QDE11560
*630	60	260	643	685	390	57,2	44.260	QDE11630
*710	67	280	737	800	380	64,5	72.000	QDE11710

\*resale products

# DIMENSIONS

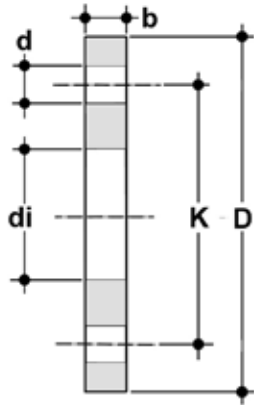

## OKDB

Profile backing ring PP with cast iron core according to DIN standard.  
Drilled: PN 10/16 up to d180, PN10 from d200 to d630.

d	DN	**PMA (bar)	b	D	d	K	M	***n	Nm	g	Code
*32	25	16	18	122	14.5	85	M12	4	15	40	OKDB032
*40	32	16	18	142	18	100	M16	4	15	50	OKDB040
*50	40	16	19	155	18	110	M16	4	20	70	OKDB050
*63	50	16	20	170	18	125	M16	4	30	90	OKDB063
*75	65	16	21	191	18	145	M16	4	40	125	OKDB075
*90	80	16	21	206	18	160	M16	8	40	130	OKDB090
*110	100	16	22	226	18	180	M16	8	40	155	OKDB110
*125	100	16	23	226	18	180	M16	8	40	140	OKDB125
*140	125	16	25	256	18	210	M16	8	50	170	OKDB140
*160	150	16	28	291	22	240	M20	8	60	250	OKDB160
*180	150	16	27	291	22	240	M20	8	60	240	OKDB180
*200	200	16	29	346	22	295	M20	8	80	350	OKDB200
*225	200	16	29	346	22	295	M20	8	80	350	OKDB225
*250	250	16	31	404	22	350	M20	12	80	435	OKDB250
*280	250	16	31	404	22	350	M20	12	80	425	OKDB280
*315	300	16	40	456	22	400	M20	12	90	750	OKDB315
*355	350	16	55	521	22	460	M20	16	110	1.135	OKDB355
*400	400	16	57.5	584	26	515	M24	16	120	1.490	OKDB400
*450	400	10	56	690	26	620	M24	20	130	2.070	OKDB450
*500	500	10	56	690	26	620	M24	20	140	1.962	OKDB500
*560	600	10	64	804	30	725	M27	20	150	3.210	OKDB560
*630	600	10	64	804	30	725	M27	20	160	2.755	OKDB630

\*resale products

\*\*PMA: maximum allowable pressure

\*\*\*n: number of bolts

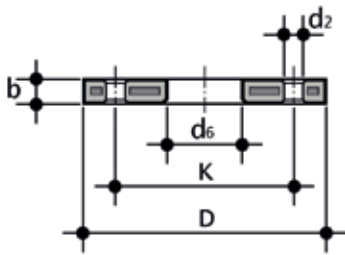

## ODB

Steel core backing ring, PP/FRP coated, according to EN/ISO/DIN. Drilled: PN 10/16 up to d180, PN10 from d200 to d630.

d	DN	**PMA (bar)	b	d <sub>2</sub>	d <sub>6</sub>	D	K	M	***n	Nm	g	Code
20	15	16	12	14	28	95	65	M12	4	15	232	ODB020
25	20	16	14	14	34	105	75	M12	4	15	288	ODB025
32	25	16	14	14	42	115	85	M12	4	15	544	ODB032
40	32	16	16	18	51	140	100	M16	4	20	836	ODB040
50	40	16	16	18	62	150	110	M16	4	30	902	ODB050
63	50	16	19	18	78	165	125	M16	4	35	1074	ODB063
75	65	16	19	18	92	185	145	M16	4	40	1368	ODB075
90	80	16	21	18	108	200	160	M16	8	40	1516	ODB090
110	100	16	22	18	128	220	180	M16	8	40	1960	ODB110
125	100	16	22	18	135	220	180	M16	8	40	1938	ODB125
140	125	16	26	18	158	250	210	M16	8	50	2866	ODB140
160	150	16	27	22	178	285	240	M20	8	60	3576	ODB160
180	150	16	27	22	191	285	240	M20	8	60	3298	ODB180
200	200	16	28	22	235	340	295	M20	8	70	5318	ODB200
225	200	16	28	22	238	340	295	M20	8	70	5500	ODB225
250	250	16	31	22	288	406	350	M20	12	80	6962	ODB250
280	250	16	31	22	294	406	350	M20	12	80	7092	ODB280
315	300	16	34	22	338	460	400	M20	12	100	9428	ODB315
*355	350	16	39	23	377	520	460	M20	16	120	19285	ODB355
*400	400	16	43	27	430	580	515	M24	16	140	21370	ODB400
*450	450	10	44	26	516	670	620	M24	20	150	30000	ODB450
*500	500	10	45	26	533	678	620	M24	20	150	34000	ODB500
*560	600	10	50	30	618	790	725	M27	20	170	49000	ODB560
*630	600	10	50	30	645	790	725	M27	20	170	40000	ODB630

\*resale products

\*\*PMA: maximum allowable pressure

\*\*\*n: number of bolts



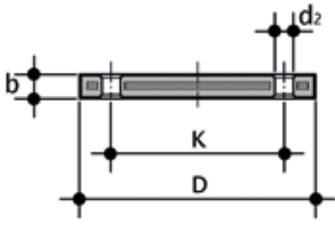

## ODBC

Steel core blind flange, PP/FRP coated, according to EN/ISO/DIN. Drilling PN 10/16 up to d160/180, PN 10 from d200/225 to d400

d	DN	**PMA (bar)	b	d <sub>2</sub>	D	k	M	***n	Nm	g	Code
*20	15	10	16	14	95	65	M12	4	15	290	ODBC020
*25	20	10	12	18	105	75	M12	4	15	380	ODBC025
*32	25	10	18	14	115	85	M12	4	15	600	ODBC032
*40	32	10	17	18	140	100	M16	4	25	830	ODBC040
*50	40	10	18	18	150	110	M16	4	35	1105	ODBC050
*63	50	10	18	18	165	125	M16	4	35	1308	ODBC063
*75	65	10	18	18	185	145	M16	4	40	1580	ODBC075
*90	80	10	20	18	200	160	M16	8	40	2244	ODBC090
*110	100	10	20	18	220	180	M16	8	45	2829	ODBC110
*140	125	10	24	18	250	210	M16	8	50	3920	ODBC140
*160	150	10	22	22	285	240	M20	8	60	7181	ODBC160
*180	150	10	24	22	285	240	M20	8	60	7130	ODBC180
*200	200	10	24	22	340	295	M20	8	70	10580	ODBC200
*250	250	10	30	22	395	350	M20	12	100	14040	ODBC250
*280	250	10	30	22	395	350	M20	12	100	14040	ODBC280
*315	300	16	34	22	445	400	M20	12	110	26480	ODBC315
*350	350	10	39	22	505	460	M20	16	160	39000	ODBC355
*400	400	10	46	25	574	515	M24	16	170	50400	ODBC400

\*resale products

\*\*PMA: maximum allowable pressure

\*\*\*n: number of bolts

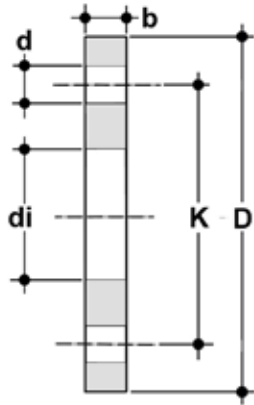

## OKAB

Profiled backing ring PP with cast iron core for stub flange according to ANSI B16.5 class 150

d	DN	**PMA	b	D	d	K	M	***n	Nm	g	Code
*63	50	16	18	164	19	121	M16	4	30	0.72	OKAB200
*90	80	16	19	196	19	153	M16	4	40	0.94	OKAB300
*110	100	16	25	237	19	191	M16	8	40	1.84	OKAB400
*160	150	16	30	297	22	242	M20	8	60	2.8	OKAB600
*225	200	16	34	354	22	299	M20	8	80	4,6	OKAB800
*250	250	16	38	425	26	362	M20	12	90	6.56	OKAB810
*315	300	16	51	497	26	432	M20	12	100	11.28	OKAB812

\*resale products

\*\*PMA: maximum allowable pressure

\*\*\*n: number of bolts

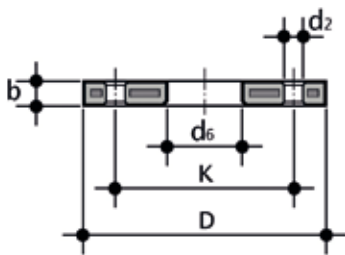

## OAB

Steel core backing ring, PP/FRP coated, according to ANSI B16.5 cl.150

d(inch)	DN	**PMA (bar)	b	d <sub>2</sub> (mm)	d <sub>2</sub> (inch)	d <sub>6</sub>	D	k (mm)	k (inch)	***n	Nm	g	Code
1/2"	15	16	12	16	5/8"	28	95	60.45	2" 3/8	4	15	200	OAB012
3/4"	20	16	12	16	5/8"	34	102	69,85	2" 3/4	4	15	240	OAB034
1"	25	16	16	16	5/8"	42	114	79,25	3" 1/8	4	15	490	OAB100
1" 1/4	32	16	16	16	5/8"	51	130	88,9	3" 1/2	4	25	670	OAB114
1" 1/2	40	16	18	16	5/8"	62	133	98,55	3" 7/8	4	35	640	OAB112
2"	50	16	18	20	3/4"	78	162	120,65	4" 3/4	4	35	1000	OAB200
2" 1/2	65	16	18	20	3/4"	92	184	139,7	5" 1/2	4	40	1310	OAB212
3"	80	16	18	20	3/4"	111	194	152,4	6"	4	40	1250	OAB300
4"	100	16	18	20	3/4"	133	229	190,5	7" 1/2	8	40	1660	OAB400
6"	150	16	27	22	7/8"	178	285	240	9" 1/2	8	60	3576	ODB160
8"	200	10	24	22	7/8"	236	345	298,45	11" 3/4	8	70	5140	OAB800
10"	250	10	27	25	1"	288	412	361,95	14" 1/4	12	100	8080	OAB810
12"	315	10	32	25	1"	338	487	431,8	17"	12	110	15380	OAB812
*14"	355	10	42	28,5	1" 1/8	376	533	476,2	17" 3/4	12	110	24940	OAB814
*16"	400	10	44	28,5	1" 1/8	430	596	539,7	18" 13/32	16	110	34770	OAB816

\*resale products

\*\*PMA: maximum allowable pressure

\*\*\*n: number of bolts

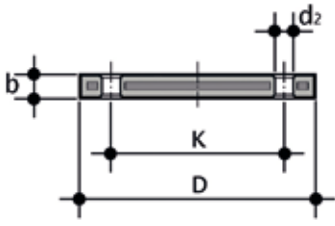

## OABC

Steel core blind flange, PP/FRP coated, according to ANSI B16.5 cl.150

Inch	DN	**PMA (bar)	B	D	d <sub>2</sub> (mm)	d <sub>2</sub> (inch)	K(mm)	K(inch)	***n	Nm	g	Code
*1/2"	15	16	12	95	16	5/8"	60,45	2" 3/8	4	15	200	OABC012
*3/4"	20	16	12	102	16	5/8"	69,85	2" 3/4	4	15	240	OABC034
*1"	25	16	16	114	16	5/8"	79,25	3" 1/8	4	15	370	OABC100
*1" 1/4	32	16	16	130	16	5/8"	88,90	3" 1/2	4	25	530	OABC114
*1" 1/2	40	16	18	133	16	5/8"	98,55	3" 7/8	4	35	560	OABC112
*2"	50	16	18	162	20	3/4"	120,65	4" 3/4	4	35	810	OABC200
*2" 1/2	65	16	18	184	20	3/4"	139,70	5" 1/2	4	40	1070	OABC212
*3"	80	16	18	194	20	3/4"	152,40	6"	4	40	1030	OABC300
*4"	100	16	18	229	20	3/4"	190,50	7" 1/2	8	40	1570	OABC400
*6"	150	16	24	283	22	7/8"	241,3	9" 1/2	8	60	2400	OABC600
*8"	200	16	24	345	22	7/8"	298,45	11" 3/4	8	70	3500	OABC800
*10"	250	16	27	412	25	1"	361,95	14" 1/4	12	100	6200	OABC810
*12"	300	16	32	487	25	1"	431,8	17"	12	110	13040	OABC812

\*resale products

\*\*PMA: maximum allowable pressure

\*\*\*n: number of bolts



# SHORT SPIGOT FITTINGS

ISO-BSP Adaptor fittings



# SHORT SPIGOT FITTINGS

Series of fittings designed for conveying fluids under pressure with a thread and weld connection system (butt welding).

## ISO-BSP ADAPTOR FITTINGS

Technical specifications	
<b>Size range</b>	d 20 ÷ 63 (mm); R 1/2" ÷ 2"
<b>Nominal pressure</b>	SDR 11 (PN16) with water at 20 °C
<b>Temperature range</b>	-40 °C ÷ 60 °C
<b>Coupling standards</b> <b>Reference standards</b>	<b>Welding:</b> EN ISO 15494. Can be coupled to pipes according to EN ISO 15494 <b>Thread:</b> ISO 228-1, DIN 2999 <b>Construction criteria:</b> EN ISO 15494 <b>Test methods and requirements:</b> EN ISO 15494 <b>Installation criteria:</b> DVS 2202-1, DVS 2207-1, UNI EN 12201-3, UNI 10520, ISO 21307, UNI 10521, UNI EN 1555-3, ISO 4427-3, ISO 4437-3
<b>Fitting material</b>	PE-HD

# TECHNICAL DATA

## PRESSURE VARIATION ACCORDING TO TEMPERATURE

For water and non-hazardous fluids with regard to which the material is classified as CHEMICALLY RESISTANT. In other cases, a reduction of the nominal pressure PN is required.  
SDR 11 ISO-S5 - 25 years

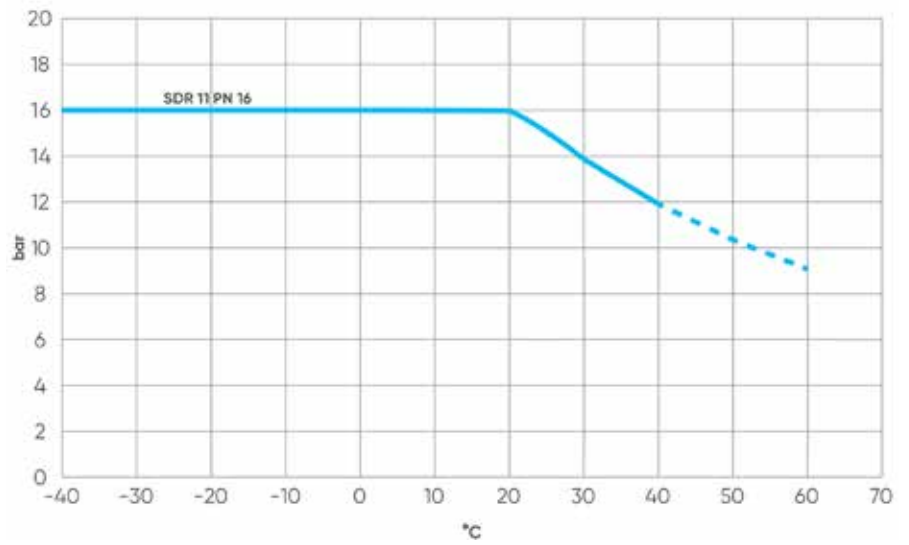

# DIMENSIONS

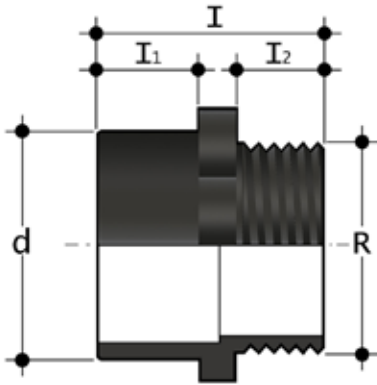

## KBFE

Adaptor with short spigot for butt welding, BSP (R) threaded male end, SDR 11 - S5

d	R	I	I <sub>1</sub>	I <sub>2</sub>	g	PN16 code SDR 11 - S 5
20	1/2"	46	20	18,0	7	KBFE11020012
25	3/4"	51.5	23	20,5	10	KBFE11025034
32	1"	60	28	24,0	20	KBFE11032100
40	1" 1/4	66.5	30	26,5	35	KBFE11040114
50	1" 1/2	72	33	27,0	59	KBFE11050112
63	2"	79.5	35	32,5	90	KBFE11063200

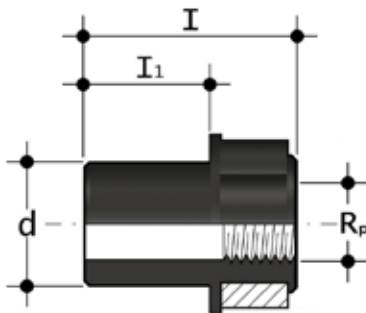

## DBME

Adaptor for butt welding, BSP (Rp) threaded female end, SDR 11 - S5

d	R <sub>p</sub>	I	I <sub>1</sub>	g	PN16 code SDR 11 - S 5
*20	1/2"	65	41	16	DBME11020012
25	1/2"	37	16	16	DBME11025012**
*25	3/4"	63	41	22	DBME11025034
*32	1"	71	44	41	DBME11032100
*40	1" 1/4	79	49	62	DBME11040114
*50	1" 1/2	88	55	82	DBME11050112
*63	2"	97	63	143	DBME11063200

\* resale products

\*\* Reduced adaptor, with metal ring reinforcement on female threaded end. Reduced PN.



# ELECTROFUSION FITTINGS



# ELECTROFUSION FITTINGS

Series of Electrofusion fittings designed for conveying fluids in industrial applications.

## ELECTROFUSION FITTINGS

Technical specifications	
<b>Size range</b>	d 16 ÷ 1000 (mm)
<b>Nominal pressure</b>	SDR 11 - SDR 17 up to PN16 with water at 20 °C
<b>Temperature range</b>	-40 °C ÷ 60 °C
<b>Reference standards</b>	<b>Construction criteria:</b> UNI EN ISO 15494, UNI EN 12201-3
<b>Fitting material</b>	PE-HD

# DIMENSIONS

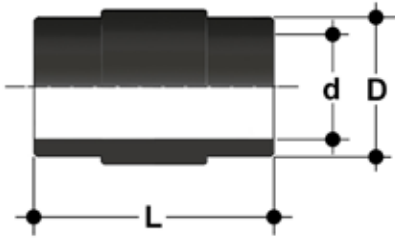

## Slide over coupler (UB), SDR 11

Electrofusion slide over coupler, SDR 11

d	D	L	g	Code SDR 11 - S 5
16	29	60	30	616577
32	45	77	64	612662
40	54	86	96	612663
50	68	98	151	612664
63	82	112	225	612665
75	98	122	360	612666
90	114	157	510	612667
110	137	159	705	612668
125	156	172	946	612669
140	174	184	1.270	615001
160	199	190	1.772	612671
180	220	210	2.088	612672
200	247	220	2.798	612673
225	277	236	3.950	612674
250	315	246	5.800	612675
280	347	285	7.740	615073
315	390	300	10.040	612670
355	445	300	14.600	615074
400	500	320	20.800	615075
450	560	340	30.000	615076
500	630	360	40.000	615124
560	715	380	55.000	616312
630	810	420	79.600	616269
710	900	442	101.000	616313
800	1000	500	138.800	616314
900	1130	600	210.300	616440
1000	1200	680	223.600	616989

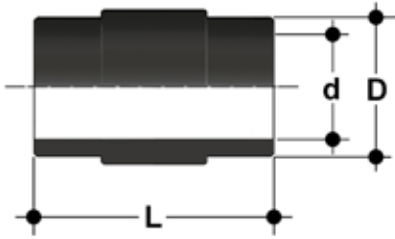

## Slide over coupler (UB), SDR 17

Electrofusion slide over coupler, SDR 17

d	D	L	g	Code SDR 17 - S 8
315	356	280	5.880	616529
355	400	290	7.600	616530
400	450	300	10.100	616531
450	506	320	13.650	616532
500	562	350	18.250	616533
560	630	380	24.190	615706
630	710	420	34.870	615726
710	800	442	46.000	615994
800	900	500	65.900	616290
900	1024	500	91.500	616345
1000	1130	610	128.000	616403
1200	1356	670	205.000	616416

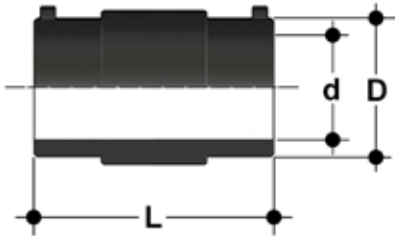

## Couplers with removable stop (MB)

Electrofusion coupler with removable stop, SDR 11

d	D	L	g	Code SDR 11 - S 5
20	33	60	40	612680
25	38	66	47	612681
32	45	78	64	612682
40	54	86	100	612683
50	68	98	150	612684
63	82	110	221	612685
75	98	122	360	612686
90	114	157	510	612687
110	137	159	710	612688
125	156	172	950	612689
140	174	184	1.270	612690
160	199	190	1.770	612691

# DIMENSIONS

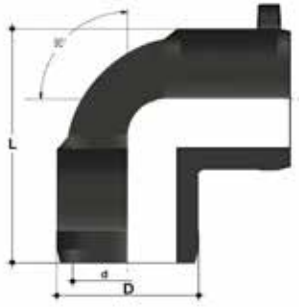

**ELBOW 90° (W90)**  
Electrofusion Elbow W90 SDR11

d	D	L	g	Code
20	28.5	71	40	616686
25	37	73	60	612091
32	43	82	70	612093
40	53	96	110	612095
50	66	113	190	612097
63	83	136	340	612099
75	96	170	600	612101
90	115	202	950	612103
110	138	234	1.560	612105
125	157	254	2.030	612107
160	207	329	4.850	615276
180	228	354	5.760	615689
200	254	392	8.557	616265
225	280	430	10.220	615690
250	310	534	19.100	616408
280	350	621	27.500	616409
315	396	677	40.000	616410



# CUSTOMIZED SOLUTIONS

Wall ducts, seamless bends, segmented fittings



# WALL DUCTS

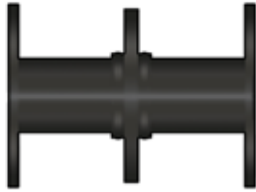

## CODING SYSTEM

Item code: **XX.XX.XX.XXX**

Position 1-2	Dowels	Position 3-4	Dimension	Position 5-6	Flange connector	Position 7-8-9	Material	Supplementary text (mm)	Length
75	Galvanized	03 ÷ 91*	Diameter	10	One side	106	PE100	L = xxx	Customized length
76	Stainless steel (VA4)			20	Both sides				
77	Combined, stainless steel on one side and galvanized steel on the other side			20	Both sides	206	pp		
						500	PVC-U		

\*Code Dimensions (position 3-4):

Position	Diameter	DN(Flange)	Position	Diameter	DN(Flange)
03	d32	25	34	d355	300
04	d40	32	35	d355	350
05	d50	40	39	d400	350
06	d63	50	40	d400	400
07	d75	65	44	d450	400
09	d90	80	45	d450	500
11	d110	100	50	d500	500
12	d125	100	54	d560	500
13	d125	125	56	d560	600
14	d140	125	63	d630	600
16	d160	150	71	d710	700
18	d180	150	80	d800	800
20	d200	200	90	d900	900
22	d225	200	91	d1000	1000
25	d250	250			
28	d280	250			
31	d315	300			



**Additional but not common flanged connectors (position 5-6):**

- 11 Flange connector on one side, second side with elbow 90°
- 30 Clamping flange for foil
- 78 Flange connector on one side with female threaded socket 1/2"
- 79 Flange connector on one side with female threaded socket 3/4"
- 80 Flange connector on one side with female threaded socket 1"
- 81 Flange connector on one side with female threaded socket 1 1/4"
- 82 Flange connector on one side with female threaded socket 1 1/2"
- 83 Flange connector on one side with female threaded socket 2"
- 84 Flange connector on one side with female threaded socket 2 1/2"
- 45 Gutter box with flange
- 42 Gutter box without flange

**Note:** All sleeve dowels are only available in metric, no inch

**Standard:** Up to d 630 in SDR 17 bigger dimensions are in SDR 33 → other SDR on request (ordered in supplementary text)  
Standard length is 250 mm  
Always PN10 → Up to DN 150 PN10 and PN16 are identical, from DN200 if PN16 required please mention in supplementary text  
Further custom designs on request

**Example:** 75.03.10.106 L= 250 mm  
Dowels in galvanized steel, d32, DN25, flanged connector on one side, PE 100

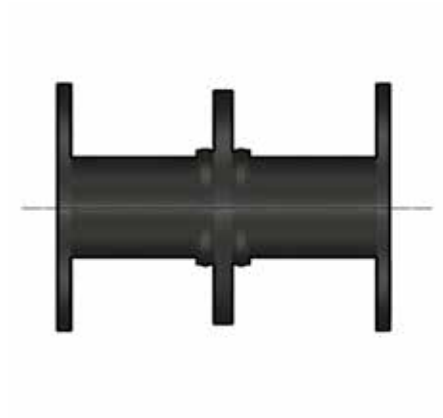

30

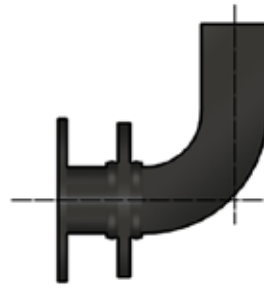

11

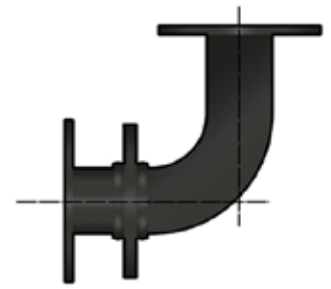

31

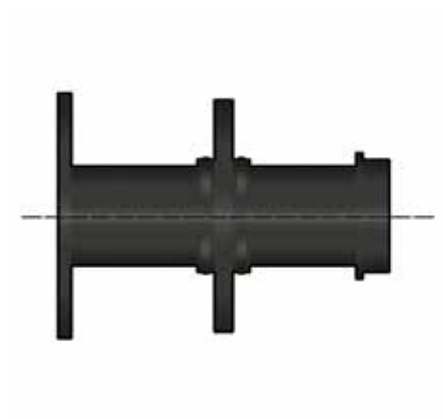

78 ÷ 84



45



42

# SEAMLESS BEND - R=1,5XD

PE 100



## CODING SYSTEM

Item code: X(XX)XXXXXX

Position 1	Fitting	Position 2-3	Angle (if different from 90°)	Position 4-5	Welding type	Position 6-7	SDR	Position 8-9-10	Dimension
S	Seamless bend	11	11°	BE	Butt welding and Electrofusion	11 17	SDR11 SDR17	050 ÷ 450	Diameter (mm)
		22	22°						
		30	30°						
		45	45°						
		60	60°						

\* standard radius 1.5xD, other radius on request

**Example:** S22BE17050

Bend seamless formed R=1,5, 22°, butt welding and electrofusion PE, SDR 17, d50 diameter.

SBE11050

Bend seamless formed R=1,5, 90°, butt welding and electrofusion PE, SDR 11, d50 diameter.

# SEGMENTED FITTINGS



## CODING SYSTEM

Item code: **XX.XX.XX.XXX**

### T-Pieces

Position 1-2	Fitting type	Position 3-4	Dimension	Position 5-6	Feature	Position 7	Material	Position 8-9	SDR
29	Saddle-T-Piece	09 ÷ 50*	Diameter	05 ÷ 40*	Diameter 2	5	PE 100	11 17 33	SDR 11 SDR 17 SDR 33
39	T-Piece	22 ÷ 63*		02	Welded				
90	Thread Saddle-T-Piece	07 ÷ 50*		78 ÷ 84*	Thread female end	2	PP	10 06	SDR 11 SDR 17,6

### Branches

Position 1-2	Fitting type	Position 3-4	Dimension	Position 5-6	Feature	Position 7	Material	Position 8-9	SDR
30	45°-branch, equal	11 ÷ 45*	Diameter	11 ÷ 45*	Diameter 2 identical with d1	5	PE 100	11 17 33	SDR 11 SDR 17 SDR 33
30	45°-branch, reduced	14 ÷ 45*			Diameter 2 (branch)				
35	60°-branch, equal	11 ÷ 45*			Diameter 2 identical with d1	2	PP	10 06	SDR 11 SDR 17,6
35	60°-branch, reduced	14 ÷ 45*			Diameter 2 (branch)				

## Segmented bends

Position 1-2	Fitting type	Position 3-4	Dimension	Position 5-6	Feature	Position 7	Material	Position 8-9	SDR
18	Segmented bend	11 ÷ 80*	Diameter	93 60 45 30	90° 60° 45° 30°	5	PE 100	11 17 33	SDR 11 SDR 17 SDR 33
11	Welded bends, injected extended with pipe	11 ÷ 50*		46	45°	2	PP	10 06	SDR 11 SDR 17,6

\*Code Dimensions (position 3-4):

Position	Diameter
07	d75
09	d90
11	d110
12	d125
13	d125
14	d140
16	d160
18	d180
20	d200
22	d225
25	d250
28	d280
31	d315
34	d355
35	d355
39	d400
40	d400
44	d450
45	d450
50	d500
54	d560
56	d560
63	d630
71	d710
80	d800

\*Code Threads (position 5-6):

Position	Thread
78	1/2"
79	3/4"
80	1"
81	1 1/4"
82	1 1/2"
83	2"
84	2 1/2"

**Note:** For BW and EF  
Other dimensions on request

**Example:** 18.11.93.533  
Segmented bend, d110, 90°, PE 100, SDR11



# VALVES

For PE system



# VKD DN 15÷50

FIP has developed a VKD DUAL BLOCK® ball valve to introduce a high reference standard in thermoplastic valve design. VKD is a True Union ball valve that meets the most stringent needs required by industrial applications.



## DUAL BLOCK® 2-WAY BALL VALVE

- Patented **SEAT STOP®** ball carrier system that lets you micro-adjust ball seats and minimise the axial force effect
- Easy radial dismounting allowing quick replacement of O-rings and ball seats without any need for tools
- **PN16 True Union valve body** made for rigid PVC-U injection moulding equipped with built-in bores for actuation. ISO 9393 compliant test requisites
- Option of dismounting downstream pipes with the valve in the closed position
- Floating **full bore ball** with high surface finish
- **Integrated bracket** for valve anchoring
- Ball seat carriers can be adjusted using the **Easytorque adjustment kit**
- Possibility to have handle with integrated LSQT limit micro switch, even as a retrofit in existing installations

Technical specifications	
<b>Construction</b>	2-way True Union ball valve with locked carrier and union nuts.
<b>Size range</b>	DN 15 ÷ 50
<b>Nominal pressure</b>	PN 16 with water at 20 °C
<b>Temperature range</b>	0 °C ÷ 60 °C
<b>Reference standards</b>	<b>Construction criteria:</b> EN ISO 16135, EN ISO 1452, EN ISO 15493 <b>Test methods and requirements:</b> ISO 9393 <b>Installation criteria:</b> DVS 2204, DVS 2221, UNI 11242 <b>Actuator couplings:</b> ISO 5211
<b>Valve material</b>	PVC-U
<b>Seal material</b>	EPDM (standard size O-Ring); PTFE (ball seats)
<b>Control options</b>	Manual control; electric actuator; pneumatic actuator



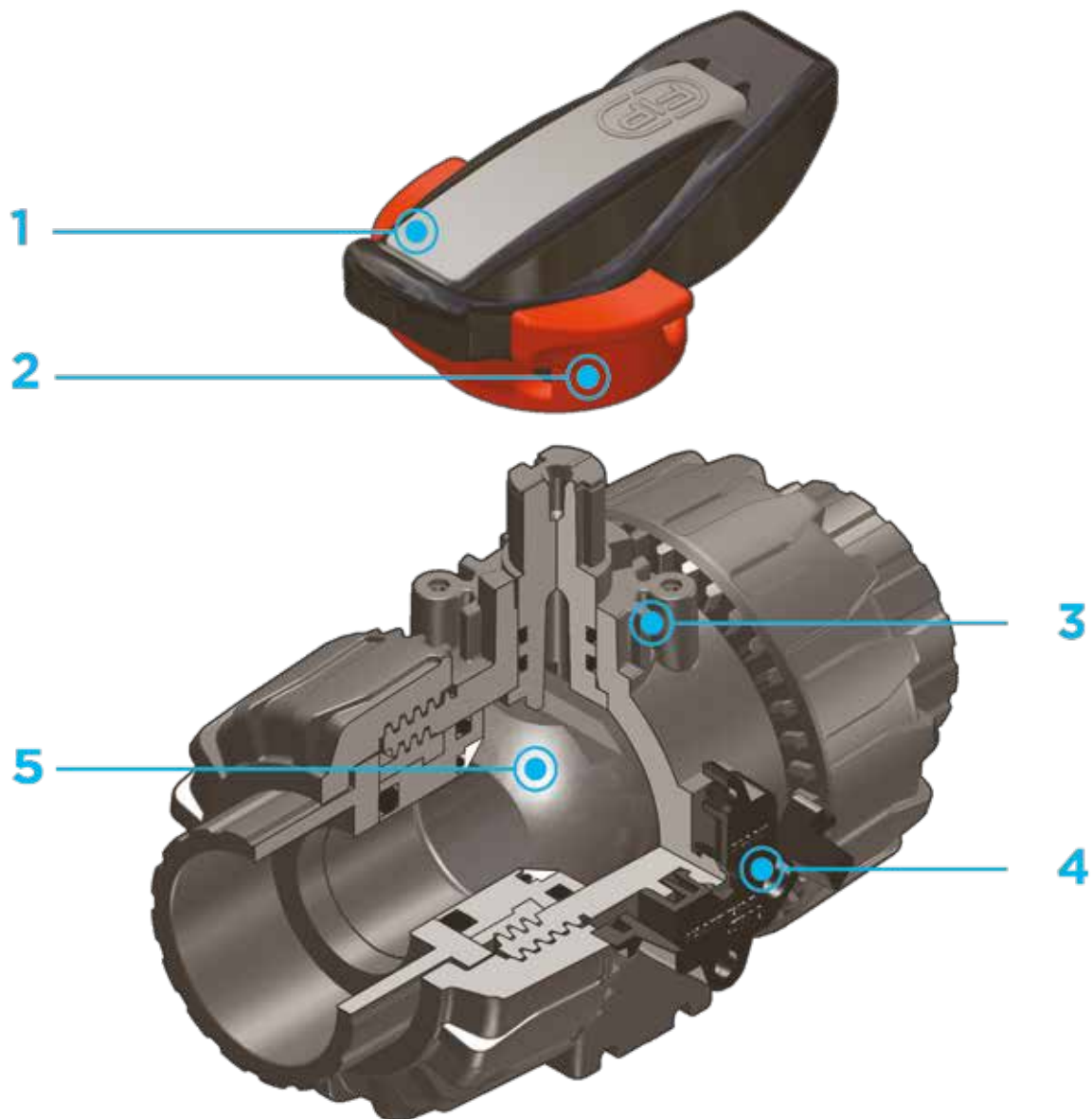

**1** Ergonomic HIPVC handle equipped with **removable tool to adjust the ball seat carrier.**

**2** **Handle lock 0°- 90° SHKD** (available as an accessory) ergonomically operable during service and padlockable

**3** Robust **integrated bracket for valve anchoring**, for easy and quick automation even after valve installation on the system via the Power Quick module (optional)

**4** **DUAL BLOCK®** patented lock system that ensures union nut

tightening hold even in severe conditions such as vibrations or heat dilation

**5** Machined high surface finish ball that guarantees a smooth operation and increased reliability

# TECHNICAL DATA

## PRESSURE VARIATION ACCORDING TO TEMPERATURE

For water and harmless fluids to which the material is classified as CHEMICALLY RESISTANT. In other cases, a reduction of the nominal PN pressure is required (25 years with safety factor).



## PRESSURE DROP GRAPH

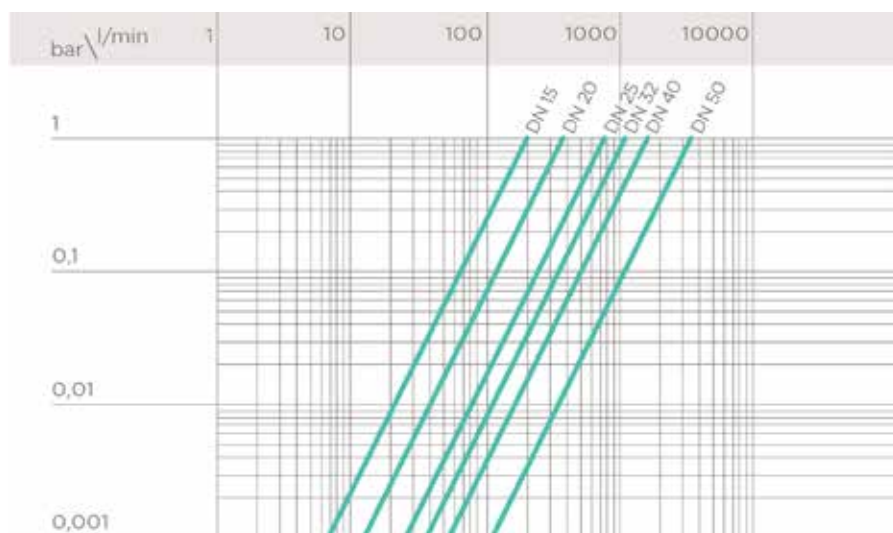

## K<sub>v</sub>100 FLOW COEFFICIENT

The K<sub>v</sub>100 flow coefficient is the Q flow rate of litres per minute of water at a temperature of 20°C that will generate Δp= 1 bar pressure drop at a certain valve position. The Kv100 values shown in the table are calculated with the valve completely open.

DN	15	20	25	32	40	50
Kv100 l/min	200	385	770	1100	1750	3400

## OPERATING TORQUE AT MAXIMUM WORKING PRESSURE

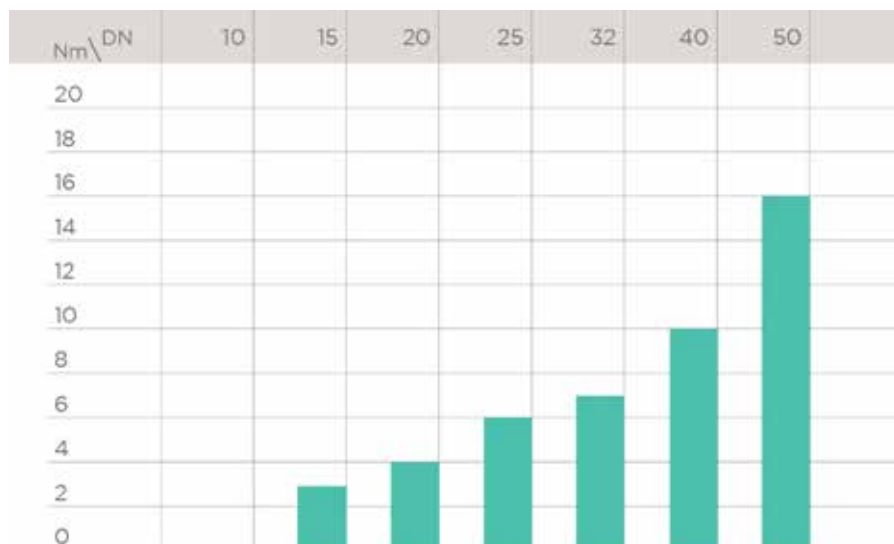

The information in this leaflet is provided in good faith. No liability will be accepted concerning technical data that is not directly covered by recognised international standards. FIP reserves the right to carry out any modification. Products must be installed and maintained by qualified personnel.

# DIMENSIONS

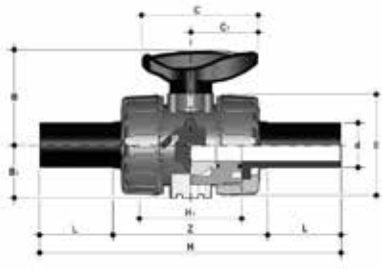

## VKDBEV

DUAL BLOCK® 2-way ball valve with PE100 SDR 11 male end connectors for butt welding or electrofusion (CVDE)

d	DN	PN	B	B <sub>1</sub>	C	C <sub>1</sub>	E	H	H <sub>1</sub>	L	Z	g	EPDM code
20	15	16	54	29	67	40	54	175	65	40,5	94	220	VKDBEV020E
25	20	16	65	34,5	85	49	65	213	70	54	106	340	VKDBEV025E
32	25	16	69,5	39	85	49	73	228	78	56	117	443	VKDBEV032E
40	32	16	82,5	46	108	64	86	247	88	56	131	693	VKDBEV040E
50	40	16	89	52	108	64	98	271	93	60,5	145	945	VKDBEV050E
63	50	16	108	62	134	76	122	300	111	65,5	161	1607	VKDBEV063E

# ACCESSORIES

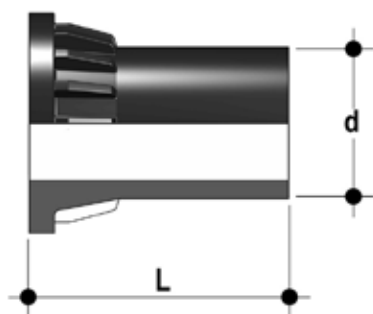

## CVDE

Long spigot PE100 end connectors for joints with electrofusion fittings or for butt welding

d	DN	PN	L	SDR	Code
20	15	16	55	11	CVDE11020
25	20	16	70	11	CVDE11025
32	25	16	74	11	CVDE11032
40	32	16	78	11	CVDE11040
50	40	16	84	11	CVDE11050
63	50	16	91	11	CVDE11063



## SHKD

Handle block kit 0° - 90° lockable

d	DN	Code
20	15	SHKD020
25 - 32	20 - 25	SHKD032
40 - 50	32 - 40	SHKD050
63	50	SHKD063

## PMKD

Wall mounting plate

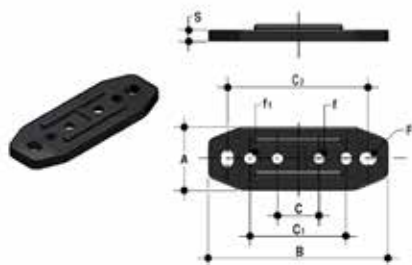

d	DN	A	B	C	C <sub>1</sub>	C <sub>2</sub>	F	f	f <sub>1</sub>	S	Code
20	15	30	86	20	46	67,5	6,5	5,3	5,5	5	PMKD1
25	20	30	86	20	46	67,5	6,5	5,3	5,5	5	PMKD1
32	25	30	86	20	46	67,5	6,5	5,3	5,5	5	PMKD1
40	32	40	122	30	72	102	6,5	6,3	6,5	6	PMKD2
50	40	40	122	30	72	102	6,5	6,3	6,5	6	PMKD2
63	50	40	122	30	72	102	6,5	6,3	6,5	6	PMKD2

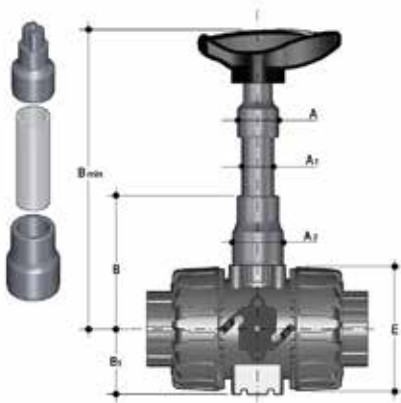

## PSKD

Stem extension

d	DN	A	A <sub>1</sub>	A <sub>2</sub>	E	B	B <sub>1</sub>	B <sub>min</sub>	Code
20	15	32	25	32	54	70	29	139,5	PSKD020
25	20	32	25	40	65	89	34,5	164,5	PSKD025
32	25	32	25	40	73	93,5	39	169	PSKD032
40	32	40	32	50	86	110	46	200	PSKD040
50	40	40	32	50	98	116	52	206	PSKD050
63	50	40	32	59	122	122	62	225	PSKD063



## Easytorque Kit

Kit for ball seat carrier tightening adjustment for DUAL BLOCK® DN 10-50 series valves

d	DN	Tightening torque recommended*	Code
1/2"	15	3 N m - 2,21 Lbf ft	KET01
3/4"	20	4 N m - 2,95 Lbf ft	KET01
1"	25	5 N m - 3,69 Lbf ft	KET01
1" 1/4	32	5 N m - 3,69 Lbf ft	KET01
1" 1/2	40	7 N m - 5,16 Lbf ft	KET01
2"	50	9 N m - 6,64 Lbf ft	KET01

\*calculated in ideal installation conditions

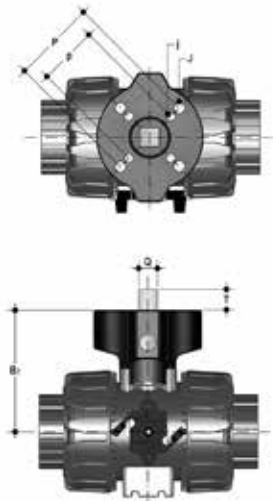

## Power Quick/CP

The valve can be equipped with pneumatic actuators, using the PP-GR module reproducing the drilling pattern foreseen by ISO 5211

d	DN	B <sub>p</sub>	Q	T	p x j	P x J	Code
20	15	58	11	12	F03 x 5,5	F04 x 5,5	PQCP020
25	20	69	11	12	*F03 x 5,5	F05 x 6,5	PQCP025
25	20				F04		PQCP025F04
32	25	74	11	12	*F03 x 5,5	F05 x 6,5	PQCP032
32	25				F04	F05 x 6,5	PQCP032F04
40	32	91	14	16	F05-07*	F07 x 8,5	PQCP040
50	40	97	14	16	F05-07*	F07 x 8,5	PQCP050
63	50	114	14	16	F05-07*	F07 x 8,5	PQCP063

\*F04 x 5.5 on request

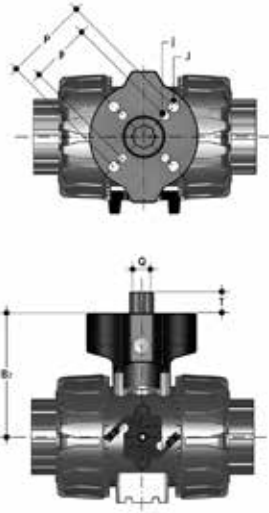

## Power Quick/CE

The valve can be equipped with electric actuators, using the PP-GR module reproducing the drilling pattern foreseen by ISO 5211

d	DN	B <sub>2</sub>	Q	T	p x j	P x J	Code
20	15	58	14	16	F03 x 5,5	F04 x 5,5	PQCE020
25	20	69	14	16	*F03 x 5,5	F05 x 6,5	PQCE025
25	20						PQCE025F04
32	25	74	14	16	*F03 x 5,5	F05 x 6,5	PQCE032
32	25						PQCE032F04
40	32	91	14	16	F05 x 6,5	F07 x 8,5	PQCE040
50	40	97	14	16	F05 x 6,5	F07 x 8,5	PQCE050
63	50	114	14	16	F05 x 6,5	F07 x 8,5	PQCE063

\*F04 x 5.5 on request

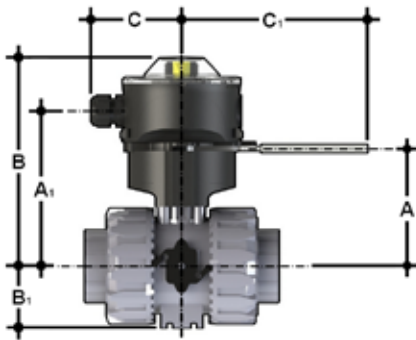

## LS Quick Kit

The Limit Switch Quick Kit allows the fast and secure installation of the FIP LSQT to the VKD valves. The body is in PP-GR and the handle is in stainless steel AISI 316. The handle block at 0° and 90° is also available by default (hole diameter 6.5 mm). The kit can be assembled on the valve even if already installed on the system. For technical data of the LSQT box see FIP actuated valves catalogue.

d	DN	A	A <sub>1</sub>	B	B <sub>1</sub>	C	C <sub>1</sub>	Code
20	15	60	91,5	137	29	76,5	157,5	LSQKIT20
25	20	71	102,5	148	34,5	76,5	157,5	LSQKIT25
32	25	76	107,5	153	39	76,5	157,5	LSQKIT32
40	32	93	124,5	170	46	76,5	157,5	LSQKIT40
50	40	99	130,5	176	52	76,5	157,5	LSQKIT50
63	50	116	147,5	193	62	76,5	157,5	LSQKIT63

# FASTENING AND SUPPORTING



All valves, whether manual or actuated, must be adequately supported in many applications. The VKD valve series is therefore ready to be equipped with threaded supporting brackets (optional) that permits direct anchoring of the valve body without the need of other components. For wall installation, dedicated PMKD mounting plates which are available as accessories can be used. These plates should be fastened to the valve before wall installation. PMKD plates also allow VKD valve alignment with FIP ZIKM pipe clips as well as allowing different sizes of valves to be aligned.

d	DN	B	H	L	J*
20	15	31,5	27	20	M4 x 6
25	20	40	30	20	M4 x 6
32	25	40	30	20	M4 x 6
40	32	50	35	30	M6 x 10
50	40	50	35	30	M6 x 10
63	50	60	40	30	M6 x 10

\* With threaded inserts

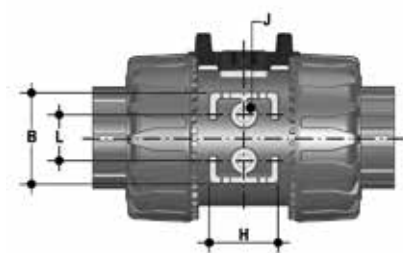



# COMPONENTS

## EXPLODED VIEW

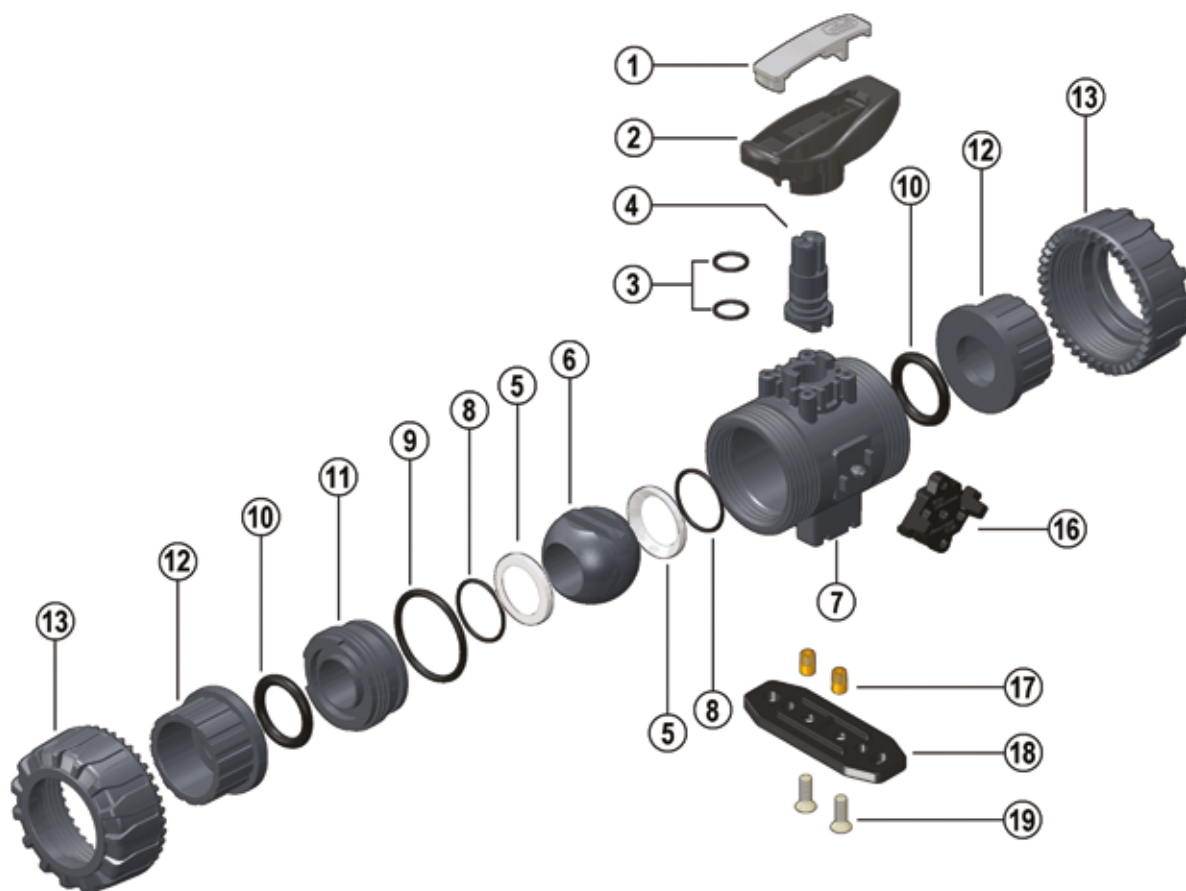

- |          |                                   |           |                                    |           |   |
|----------|-----------------------------------|-----------|------------------------------------|-----------|---|
| <b>1</b> | Handle insert (PVC-U - 1)         | <b>9</b>  | Radial seal O-Ring (EPDM-FKM - 1)* | <b>15</b> | Handle safety block (PP-GR - 1)**                 |
| <b>2</b> | Handle (HIPVC - 1)                | <b>10</b> | Socket seal O-Ring (EPDM-FKM - 2)* | <b>16</b> | DUAL BLOCK® (POM - 1)                             |
| <b>3</b> | Stem O-rings (EPDM-FKM - 2)*      | <b>11</b> | Ball seat carrier (PVC-U - 1)      | <b>17</b> | Threaded inserts (STAINLESS steel or Brass - 2)** |
| <b>4</b> | Stem (PVC-U - 1)                  | <b>12</b> | End connector (PVC-U - 2)*         | <b>18</b> | Distance plate (PP-GR - 1)**                      |
| <b>5</b> | Ball seat (PTFE - 2)*             | <b>13</b> | Union nut (PVC-U - 2)              | <b>19</b> | Screw (STAINLESS steel - 2)**                     |
| <b>6</b> | Ball (PVC-U - 1)                  | <b>14</b> | Spring (STAINLESS steel - 1)**     |           |   |
| <b>7</b> | Body (PVC-U - 1)                  |           |                                    |           |   |
| <b>8</b> | Ball seat O-Rings (EPDM-FKM - 2)* |           |                                    |           |   |

\* Spare parts

\*\* Accessories

The component material and quantity supplied are indicated in the parentheses.

## DISASSEMBLY

- 1) Isolate the valve from the line (release the pressure and empty the pipeline).
- 2) Unlock the union nuts by pressing the lever on the DUAL BLOCK® (16) along the axis and separate it from the union nut (fig. 1-2). It is also possible to completely remove the block device from the body of the valve.
- 3) Fully unscrew the union nuts (13) and extract the body sideways.
- 4) Before dismounting, hold the valve in a vertical position and open it 45° to drain any liquid that might remain.
- 5) After closing the valve, remove the special insert (1) from the handle (2) and push the two projecting ends into the corresponding recesses on the ball seat carrier (11). Rotate the stop ring anti-clockwise to extract it (fig. 3-4).
- 6) Pull the handle (2) upwards to remove it from the valve stem (4).
- 7) Press on the ball from the side opposite the "REGULAR - ADJUST" label, being sure not to scratch it, until the ball seat carrier exits (11), then extract the ball (6).
- 8) Press the stem (4) inwards until it exits the body.
- 9) Remove the O-Ring (3, 8, 9, 10) and PTFE ball seats (5) extracting them from their grooves, as illustrated in the exploded view.

## ASSEMBLY

- 1) All the O-rings (3, 8, 9, 10) must be inserted in their grooves as shown in the exploded view.
- 2) Insert the stem (4) from inside the valve body (7).
- 3) Place the PTFE ball seats (5) in the housings in the body (7) and in the ball seat ball seat carrier (11).
- 4) Insert the ball (6) rotating it to the closed position.
- 5) Screw the carrier (11) into the body and tighten up in the clockwise direction using the handle (2) to limit stop.
- 6) Insert the valve between the end connectors (12) and tighten the union nuts (13) making sure that the socket seal O-rings (10) do not exit their seats.
- 7) The handle (2) should be placed on the valve stem (4).



**Note:** during assembly operations, it is advisable to lubricate the rubber seals. Mineral oils are not recommended for this task as they react aggressively with EPDM rubber.

Fig. 1



Fig. 2



Fig. 3



Fig. 4



# INSTALLATION

Before proceeding with installation, please follow these instructions carefully:

- 1) Check that the pipes to be connected to the valve are aligned in order to avoid mechanical stress on the threaded joints.
- 2) Check that the DUAL BLOCK® union nut locking device (16) is fitted to the valve body.
- 3) To release the union nuts, axially press the release lever to separate the lock and then unscrew it in the counter-clockwise direction.
- 4) Unscrew the union nuts (13) and insert them on the pipe segments.
- 5) Solvent weld or screw the end connectors (12) onto the pipe ends.
- 6) Position the valve body between the end connectors and fully tighten the union nuts (13) manually by rotating clockwise without using wrenches or other tools that could damage the union nut surface.
- 7) Lock the union nuts by returning the DUAL BLOCK® to its housing, pressing on it until the hinges lock on the union nuts.
- 8) If necessary, support the pipework with FIP pipe clips or by means of the carrier built into the valve itself (see paragraph "fastening and carriers").

The VKD valve can be equipped with a handle lock to prevent ball rotation (supplied separately).

When the handle safety block (14, 15) is installed, lift the lever (15) and rotate the handle (fig. 6-7).

A lock can also be installed on the handle to protect the system against tampering (fig. 8).

Seal can be adjusted using the extractable insert on the handle (fig. 3-4).

The seals can be adjusted later with the valve installed on the pipe by simply tightening the union nuts. This "micro adjustment", only possible with FIP valves thanks to the patented "Seat stop system", allows the seal to be recovered where PTFE ball seats are worn due to a high number of operations. The Easytorque kit can also be used for micro adjustments (fig. 5).

## WARNINGS

- If volatile liquid such as Hydrogen Peroxide (H<sub>2</sub>O<sub>2</sub>) or Sodium Hypochlorite (NaClO) are used, for safety reasons we recommend you contact the service centre. These liquids, upon vaporising, could create hazardous over pressures in the area between the body and ball.
- Always avoid sudden closing operations and protect the valve from accidental operations.

Fig. 5



Fig. 6



Fig. 7



Fig. 8



# VKD DN 65÷100

FIP has developed a VKD DUAL BLOCK® ball valve to introduce a high reference standard in thermoplastic valve design. VKD is a True Union ball valve that meets the most stringent needs required by industrial applications. This valve is also equipped with a customisable Labelling System.



## DUAL BLOCK® 2-WAY BALL VALVE

- Patented **SEAT STOP®** ball carrier system that lets you micro-adjust seals and minimise axial force effects
- Easy radial dismounting allowing quick replacement of O-rings and ball seats without any need for tools
- **PN16 True Union valve body** made for rigid PVC-U injection moulding equipped with built-in bores for actuation. ISO 9393 compliant test requisites
- Option of dismounting downstream pipes with the valve in the closed position
- **Full bore ball** with high surface finish
- **Integrated bracket** for valve anchoring
- Possibility of installing a manual reducer or pneumatic and/or electric actuators by applying an ISO standard bore PP-GR flange
- **STAINLESS steel co-moulded stem**, with square section as per ISO 5211
- Possibility to have handle with integrated LSQT limit micro switch, even as a retrofit in existing installations

### Technical specifications

<b>Construction</b>	2-way True Union ball valve with locked carrier and union nuts.
<b>Size range</b>	DN 65 ÷ 100
<b>Nominal pressure</b>	PN 16 with water at 20° C
<b>Temperature range</b>	0 °C ÷ 60 °C
<b>Reference standards</b>	<b>Construction criteria:</b> EN ISO 16135, EN ISO 1452, EN ISO 15493 <b>Test methods and requirements:</b> ISO 9393 <b>Installation criteria:</b> DVS 2204, DVS 2221, UNI 11242 <b>Actuator couplings:</b> ISO 5211
<b>Valve material</b>	PVC-U
<b>Seal material</b>	EPDM (standard size O-ring); PTFE (ball seats)
<b>Control options</b>	Manual control; electric actuator; pneumatic actuator

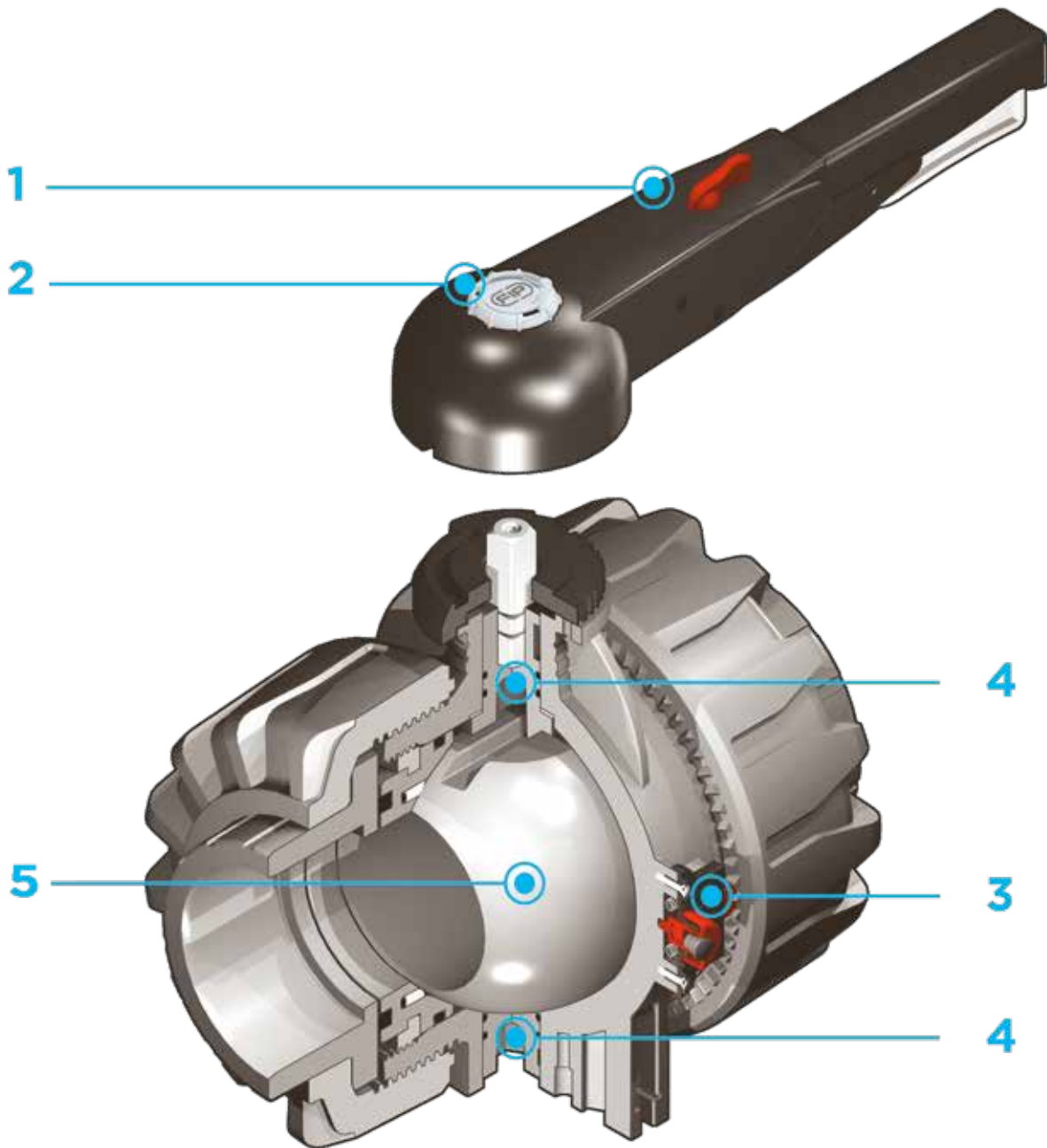

**1** HIPVC ergonomic multifunctional handle for quick operation, **lock and graduated adjustment in 10 positions**. Possibility of inhibiting rotation with a lock

**2** Customisable Labelling System: LCE module made of a transparent protection plug and **customisable tag holder** using the LSE set

(available as accessory). The customisation lets you identify the valve on the system according to specific needs

**3** **DUAL BLOCK®** patented lock system that ensures union nut tightening hold even in severe conditions such as vibrations or heat dilation

**4** **Double stem** with double O-Rings for ball centring and operating torque reduction

**5** Machined high surface finish ball that guarantees a smooth operation and increased reliability

# TECHNICAL DATA

## PRESSURE VARIATION ACCORDING TO TEMPERATURE

For water and harmless fluids to which the material is classified as CHEMICALLY RESISTANT. In other cases, a reduction of the nominal PN pressure is required (25 years with safety factor).



## PRESSURE DROP GRAPH

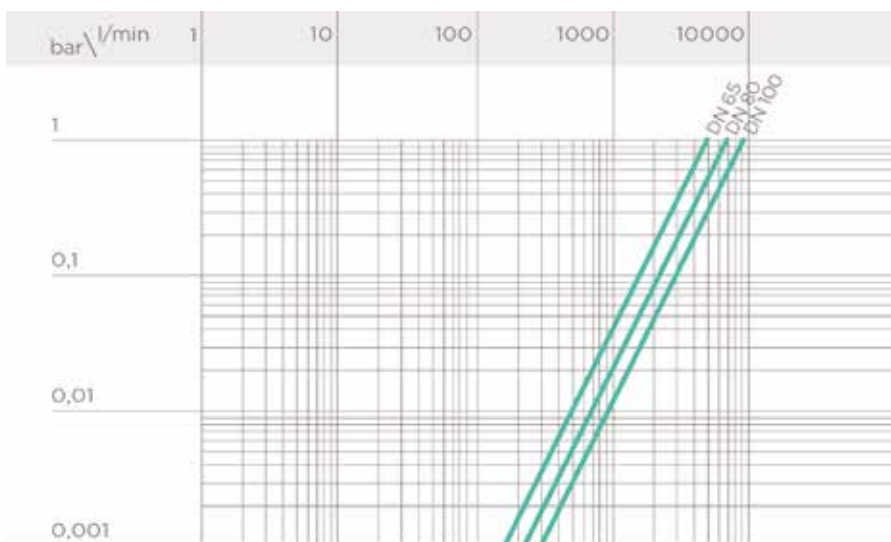

## K<sub>v</sub>100 FLOW COEFFICIENT

The K<sub>v</sub>100 flow coefficient is the Q flow rate of litres per minute of water at a temperature of 20°C that will generate Δp= 1 bar pressure drop at a certain valve position. The Kv100 values shown in the table are calculated with the valve completely open.

DN	65	80	100
K <sub>v</sub> 100 l/min	5250	7100	9500

## OPERATING TORQUE AT MAXIMUM WORKING PRESSURE

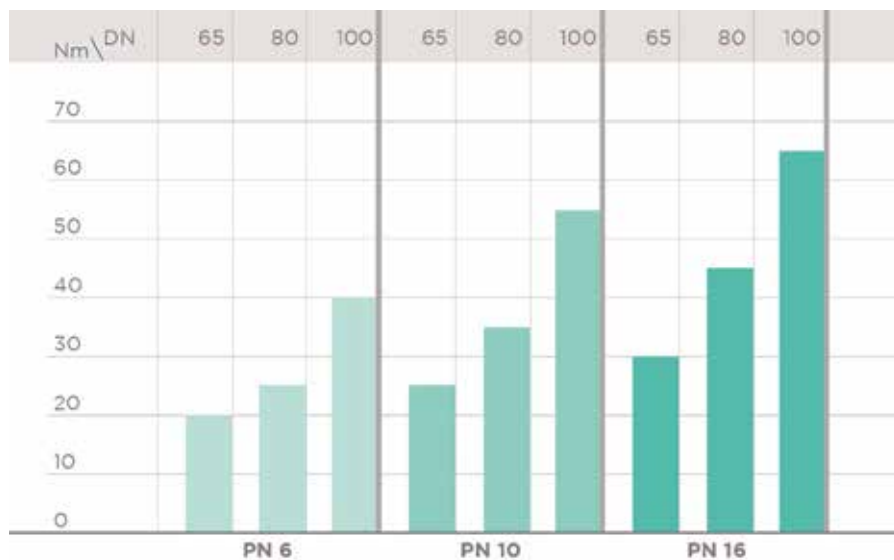

The information in this leaflet is provided in good faith. No liability will be accepted concerning technical data that is not directly covered by recognised international standards. FIP reserves the right to carry out any modification. Products must be installed and maintained by qualified personnel.

# DIMENSIONS

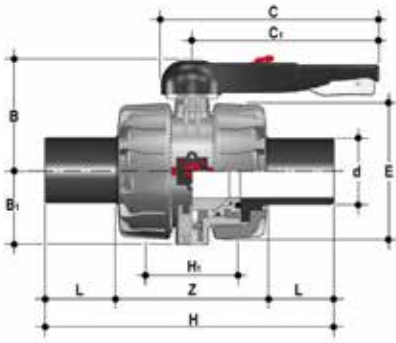

## VKDBEV

DUAL BLOCK® 2-way valve with PE100 SDR 11 male end connectors for butt welding or electrofusion (CVDE)

d	DN	PN	B	B <sub>1</sub>	C	C <sub>1</sub>	E	H	H <sub>1</sub>	L	Z	g	EPDM code
75	65	16	164	87	225	175	162	356	133	71	214	4400	VKDBEV075E
90	80	16	177	105	327	272	202	390	149	88	214	7100	VKDBEV090E
110	100	16	195	129	385	330	236	431	167	92	247	10800	VKDBEV110E



# ACCESSORIES

## CVDE

Long spigot PE100 end connectors for joints with electrofusion fittings or for butt welding

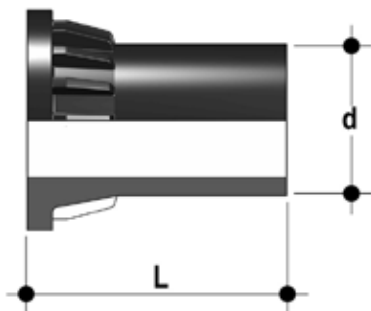

d	DN	PN	L	SDR	Code
75	65	16	111	11	CVDE11075
90	80	16	118	11	CVDE11090
110	100	16	132	11	CVDE11110

## LSE

Customisation and label printing set for Easyfit handle made up of precut adhesive sheets and software for guided label creation.



d	DN	VKD* code
75	65	LSE040
90	80	LSE040
110	100	LSE040

## LS Quick Kit

The Limit Switch Quick Kit allows the fast and secure installation of the FIP LSQT to the VKD valves. The body is in PP-GR and the handle is in stainless steel AISI 316. The handle block at 0° and 90° is also available by default (hole diameter 6.5 mm). The kit can be assembled on the valve even if already installed on the system. For technical data of the LSQT box see FIP actuated valves catalogue.

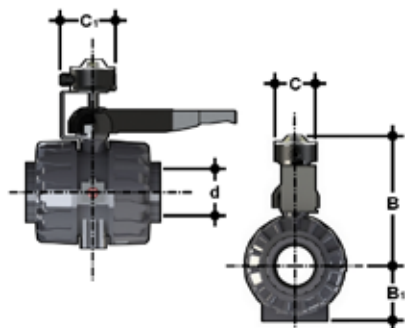

d	DN	B	B <sub>1</sub>	C	C <sub>1</sub>	Code
75	65	275	87	103	126,9	LSQKIT75160
90	80	286,7	105	103	126,9	LSQKIT75160
110	100	305,5	129	103	126,9	LSQKIT75160

## ACTUATOR MOUNTING FLANGE

The valve can be equipped with pneumatic or electric standard actuators and handwheel reduces for heavy-duty operations, using the PP-GR module reproducing the drilling pattern foreseen by ISO 5211 F07.

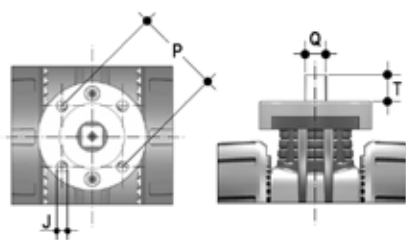

d	DN	P x J	T	Q
75	65	F07 x 9	16	14
90	80	F07 x 9	16	14
110	100	F07 x 9	19	17

# FASTENING AND SUPPORTING



All valves, whether manual or actuated, must be adequately supported in many applications.

The VKD DN 65÷100 valve series is therefore ready to be equipped with threaded supporting brackets (optional) that permits direct anchoring on the valve body without the need of other components.

Using standard threaded nuts (not included) made of STAINLESS steel, you can anchor the valve on 4 fastening points.

d	DN	J	f	l	l1	l2
75	65	M6	6,3	17,4	90	51,8
90	80	M6	8,4	21,2	112,6	63
110	100	M8	8,4	21,2	137	67

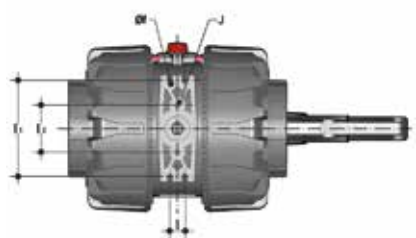

# CUSTOMISATION

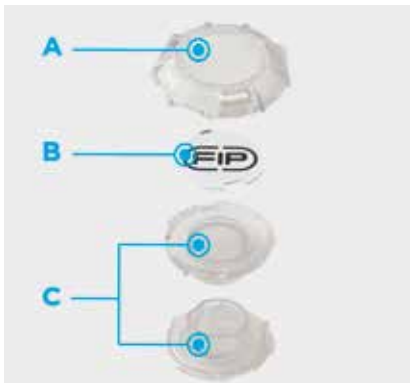

The VKD DN 65-100 valve is equipped with the customisable Labelling System. This system lets you create special labels to insert in the handle. This makes it extremely easy to apply company logos, identification serial numbers or service indications such as, for example, the valve function in the system, the transported fluid, but also specific information for customer service, such as the customer name or installation date or location on the valves.

The specific LCE module is a standard supply and is made up of a rigid transparent water-resistant PVC plug (A-C) and white tag holder (B) made of the same material, one side of which bears the FIP logo.

The holder, inserted in the plug, can be removed and, once overturned, used for customisation by applying labels printed with the software supplied with the LSE set.

Proceed as follows to apply the label on the valve:

- 1) Remove the upper part of the transparent plug (A) rotating it counter-clockwise as indicated by the "Open" label on the plug and remove it.
- 2) Extract the tag holder from its housing on the lower part of the plug (C)
- 3) Apply the adhesive label on the tag holder (B) to align the profiles matching the tab position.
- 4) Reinsert the tag holder in its housing at the bottom of the plug
- 5) Reposition the top of the plug in the housing rotating it clockwise; this way the label is protected against the elements.

# COMPONENTS

## EXPLODED VIEW

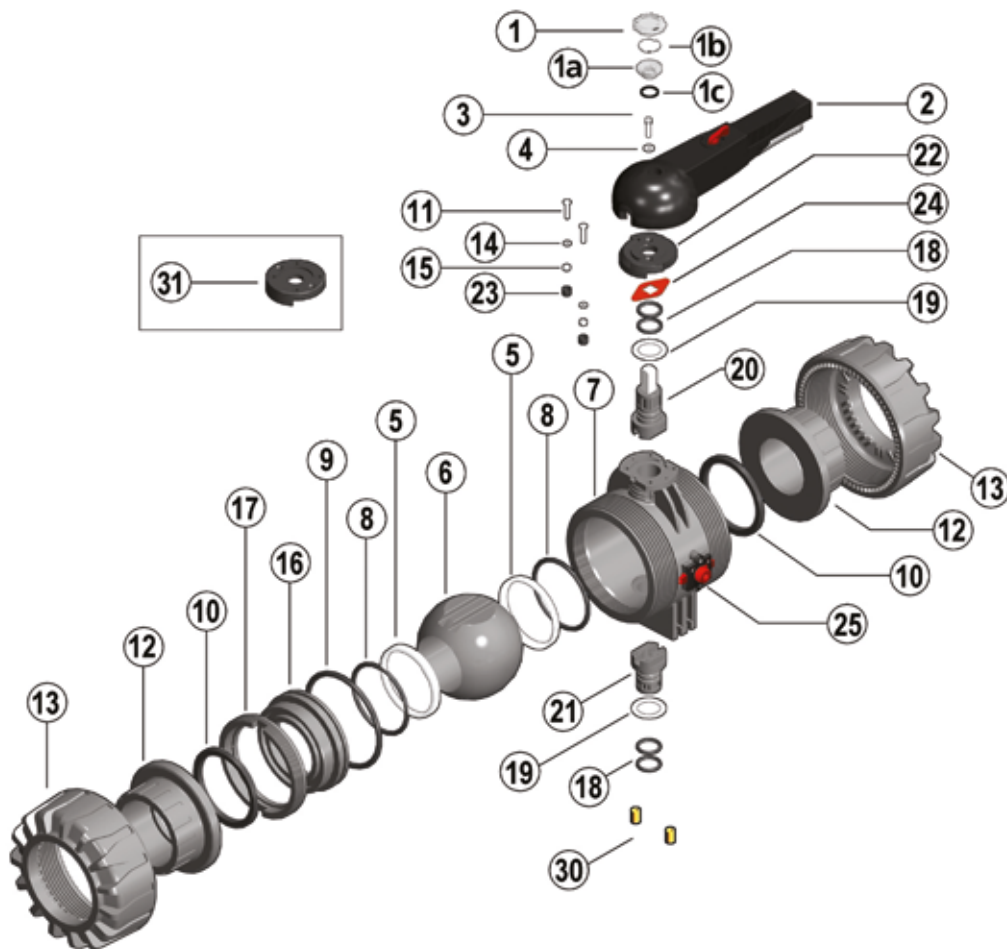

**1-1a** Transparent protection plug (PVC - 1)

**1b** Tag holder (PVC - 1)

**1c** O-Ring (NBR - 1)

**2** Handle (HIPVC - 1)

**3** Screw (STAINLESS steel - 1)

**4** Washer (STAINLESS steel - 1)

**5** Ball seat (PTFE - 2)\*

**6** Ball (PVC-U - 1)

**7** Body (PVC-U - 1)

**8** Ball seat O-ring (EPDM-FKM - 2)\*

**9** Radial seal O-Ring (EPDM - FKM - 1)\*

**10** Socket seal O-Ring (EPDM-FKM - 2)\*

**11** Screw (STAINLESS steel - 2)

**12** End connector (PVC-U - 2)

**13** Union nut (PVC-U - 2)

**14** Washer (STAINLESS steel - 2)

**15** Nut (STAINLESS steel - 2)

**16** Ball seat carrier (PVC-U - 1)

**17** Threaded ring (PVC-U - 1)

**18** Stems O-rings (EPDM-FKM - 4)\*

**19** Anti-friction disk (PTFE - 2)\*

**20** Upper stem (PVC/INOX - 1)

**21** Lower stem (PVC-U - 1)

**22** Plate (PP-GR - 1)

**23** Protection plug (PE - 2)

**24** Position indicator (PA - 1)

**25** DUAL BLOCK® (PP-GR + vari- 1)

**30** Threaded inserts (Brass - 2)\*\*

**31** Actuation plate (PP-GR - 1)\*\*

\* Spare parts

\*\* Accessories

The component material and quantity supplied are indicated in the parentheses.

## DISASSEMBLY

- 1) Isolate the valve from the line (release the pressure and empty the pipeline).
- 2) Release the union nuts by rotating the button (25) to the left, pointing the arrow on the open lock (fig. 1).
- 3) Unscrew the union nuts (13) and extract the body (7) (fig. 2).
- 4) Before dismantling, hold the valve in a vertical position and open it 45° to drain any liquid that might remain.
- 5) Open the valve.
- 6) Remove the protection plug on the handle (2) and unscrew the screw (3) with the washer (4).
- 7) Remove the handle (2).
- 8) Remove the screws (11) and plate (22) from the body (7).
- 9) Insert the two supplied wrench protrusions in the corresponding apertures on the threaded ring (17), extracting it by rotating counterclockwise with the ball seat carrier (16) (fig. 3).
- 10) Press on the ball (6), being careful not to scratch it, and remove it from the body.
- 11) Press the upper stem (20) inwards and extract it from the body and remove the lower stem (21). Remove the anti-friction disks (19).
- 12) Remove the O-Ring (8, 9, 10, 18) and PTFE ball seats (5) extracting them from their housings, as illustrated in the exploded view.

## ASSEMBLY

- 1) All the O-rings (8, 9, 10, 18) must be inserted in their grooves as shown in the exploded view.
- 2) Place the anti-friction disks (19) on the stems (20-21) and insert the stems in their housings in the body.
- 3) Place the PTFE ball seats (5) in the housings in the valve body (7) and in the carrier (16).
- 4) Insert the ball (6) rotating it to the closed position.
- 5) Insert the carrier with threaded ring (17) into the body and tighten up in the clockwise direction using the supplied tool, to limit stop.
- 6) Position the plate (22) with rack on the body, and screw in the screws (11) washers (14) and nuts (15).
- 7) The handle (2) with protection plug (1, 1a, 1b, 1c) should be placed on the stem (20) (fig. 4).
- 8) Screw in the screw (3) with the washer (4) and position the protection plug (1, 1a, 1b, 1c).
- 9) Insert the valve between the end connectors (12) and tighten the union nuts (13), making sure that the socket seal O-rings (10) do not exit their seats.
- 10) Release the union nuts by rotating the button (25) to the right, pointing the arrow on the closed lock (fig. 1).



**Note:** during assembly operations, it is advisable to lubricate the rubber seals. Mineral oils are not recommended for this task as they react aggressively with EPDM rubber.

Fig. 1



Fig. 2



Fig. 3



Fig. 4



# INSTALLATION

Before proceeding with installation, please follow these instructions carefully:

- 1) Check that the pipes to be connected to the valve are aligned in order to avoid mechanical stress on the threaded joints.
- 2) Make sure the DUAL BLOCK® union nut lock system (25) is in the FREE position.
- 3) Unscrew the union nuts (13) and insert them on the pipe segments.
- 4) Solvent weld or screw the end connectors (12) onto the pipe ends.
- 5) Position the valve body between the end connectors and fully tighten the union nuts (13) clockwise with an appropriate wrench.
- 6) Lock the union nuts rotating the button (25) clockwise (see paragraph "union nut lock").
- 7) If necessary, support the piping with FIP pipe clips or by means of the carrier built into the valve itself (see paragraph "fastening and supporting").

Adjust the ball seat carriers using the supplied tool (fig. 3).

The seals can be installed later with the valve installed on the pipe by simply tightening the union nuts. This "micro adjustment", only possible with FIP valves thanks to the patented "Seat stop system", allows the seal to be recovered where PTFE ball seats are worn due to a high number of operations.

## UNION NUT LOCK

Rotate the button to the left, pointing the arrow on the open lock to unlock DUAL BLOCK®: the valve union nuts are free to rotate clockwise and counter-clockwise. Rotate the button to the right, pointing the arrow on the closed lock to lock DUAL BLOCK®: the valve union nuts are blocked in the desired position.



## HANDLE LOCK

Thanks to the multifunctional handle and the red manoeuvre button on the lever, you can perform a 0°-90° operation and a graduated operation by means of the 10 intermediate positions and a stop lock: the handle can be locked in each of the 10 positions by simply pressing the Free-lock button. A lock can also be installed on the handle to protect the system against tampering. The valve is two-way and can be installed in any position. It can also be installed at end line or tank.



## WARNINGS

If volatile liquid such as Hydrogen Peroxide (H<sub>2</sub>O<sub>2</sub>) or Sodium Hypochlorite (NaClO) are used, for safety reasons we recommend you contact the service centre. These liquids, upon vaporising, could create hazardous over pressures in the area between the body and ball.

Always avoid sudden closing operations and protect the valve from accidental operations.



# VKR DN 15÷50

The VKR DUAL BLOCK® valve combines high reliability and safety aspects typical of VKD full bore ball valves with the new flow adjustment function with typical linear curve that meets the most stringent needs typical of industrial applications.



## DUAL BLOCK® REGULATING BALL VALVE

- Patented **SEAT STOP®** ball carrier system that lets you micro-adjust seals and minimise the axial force effect
- Easy radial dismounting allowing quick replacement of O-rings and ball seats without any need for tools
- **PN16 True Union valve body** made for rigid PVC-U injection moulding equipped with built-in bores for actuation. ISO 9393 compliant test requisites
- Option of dismounting downstream pipes with the valve in the closed position
- High surface finish stem with double O-Ring and double connection key to ball
- **Integrated bracket** for valve anchoring
- Ball seat carrier can be adjusted using the **Easytorque adjustment kit**
- Actuation option: version with electric modulating actuator with 4-20 mA / 0-10 V inlet and 4-20 mA / 0-10 V outlet to monitor the position
- Valve suitable for carrying fluids that are clean and free of suspended particles

### Technical specifications

<b>Construction</b>	2-way True Union adjusting ball valve with locked carrier and union nuts.
<b>Size range</b>	DN 15 ÷ 50
<b>Nominal pressure</b>	PN 16 with water at 20 °C
<b>Temperature range</b>	0 °C ÷ 60 °C
<b>Reference standards</b>	<b>Construction criteria:</b> EN ISO 16135, EN ISO 1452, EN ISO 15493 <b>Test methods and requirements:</b> ISO 9393 <b>Installation criteria:</b> DVS 2204, DVS 2221, UNI 11242 <b>Actuator couplings:</b> ISO 5211
<b>Valve material</b>	PVC-U
<b>Seal material</b>	EPDM (standard size O-Ring); PTFE (ball seats)
<b>Control options</b>	Manual control; electric actuator



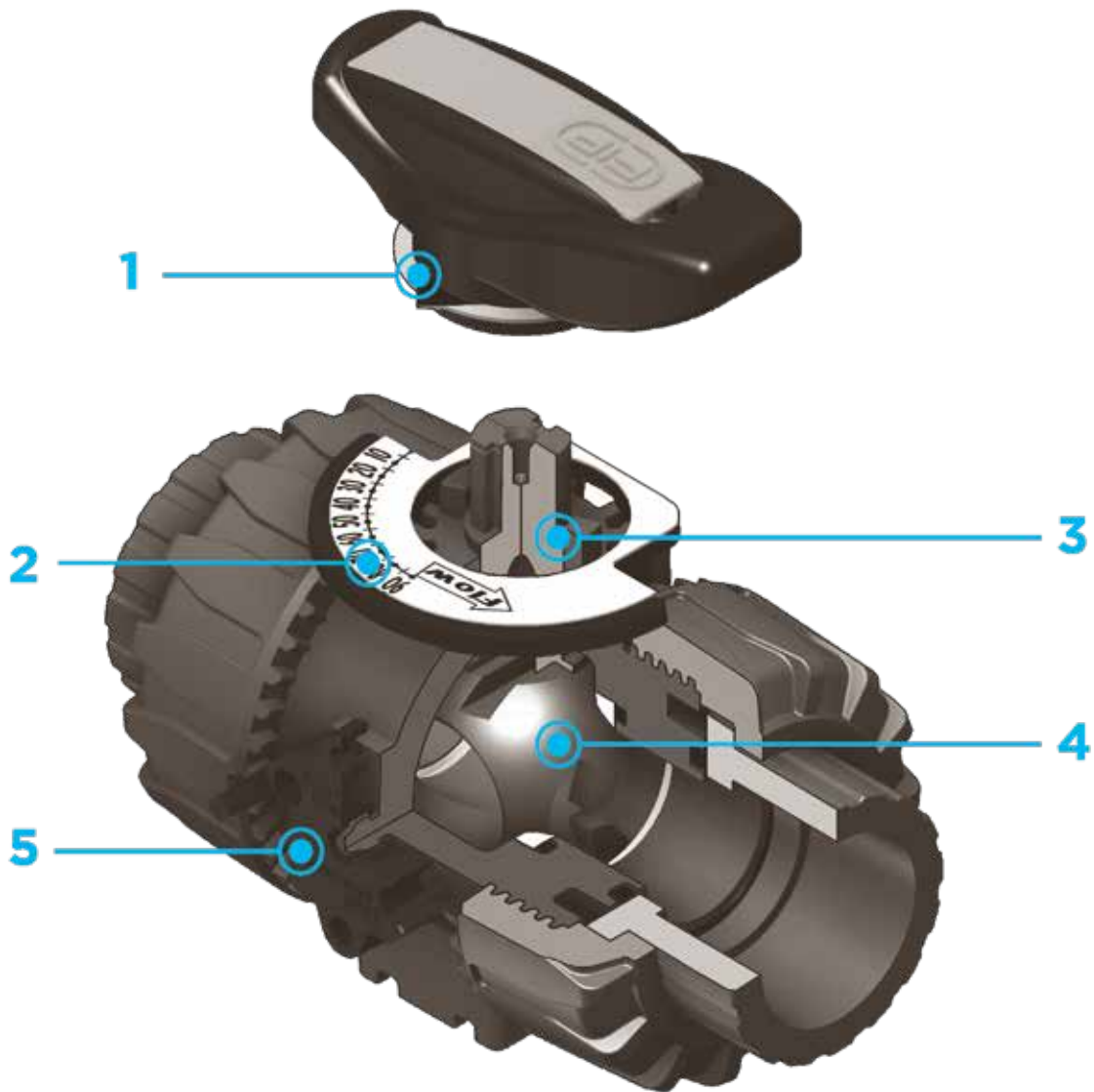

**1** HIPVC ergonomic multifunctional handle with **position indicator** and tool to adjust the ball seat carrier

**2** Flow direction and opening angle indication plate with **graduated scale with 5° detail** for clear and accurate readings

**3** 90° operating angle that permits **the use of standard** quarter turn **actuators**

**4** The patented ball design provides **linear flow adjustment** throughout its range of operation even when the valve is open just a few

degrees.

**5** Patented **DUAL BLOCK®** system: prevents union nuts from loosening even under extreme operating conditions: e.g. vibration or thermal expansion

# TECHNICAL DATA

## PRESSURE VARIATION ACCORDING TO TEMPERATURE

For water and harmless fluids to which the material is classified as CHEMICALLY RESISTANT. In other cases, a reduction of the nominal PN pressure is required (25 years with safety factor).



## PRESSURE DROP GRAPH

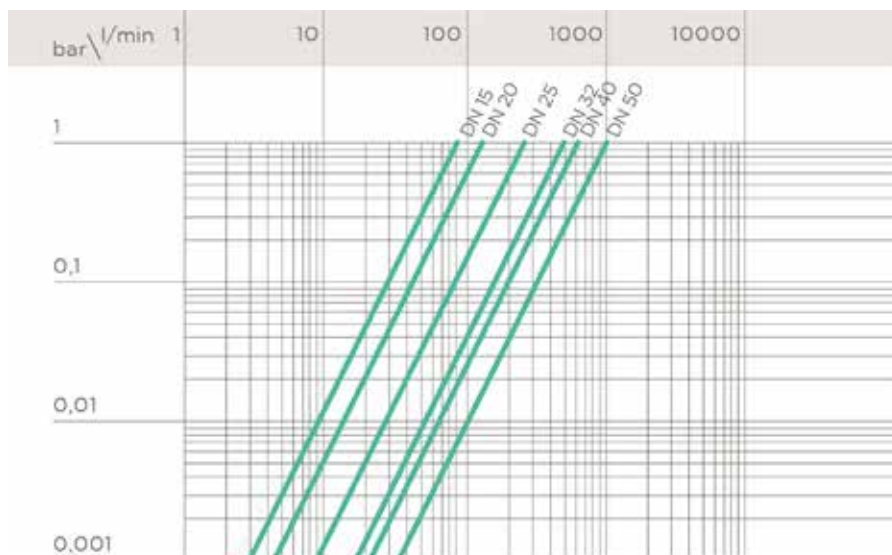

## K<sub>v</sub>100 FLOW COEFFICIENT

The K<sub>v</sub>100 flow coefficient is the Q flow rate of litres per minute of water at a temperature of 20°C that will generate Δp= 1 bar pressure drop at a certain valve position. The Kv100 values shown in the table are calculated with the valve completely open.

DN	15	20	25	32	40	50
Kv100 l/min	88	135	256	478	592	1068

## RELATIVE FLOW COEFFICIENT DIAGRAM

The relative flow coefficient is the flow rate through the valve as a function of the degree of valve aperture.

Horizontal axis: Ball aperture angle  
Vertical axis: Relative flow coefficient



## OPERATING TORQUE AT MAXIMUM WORKING PRESSURE

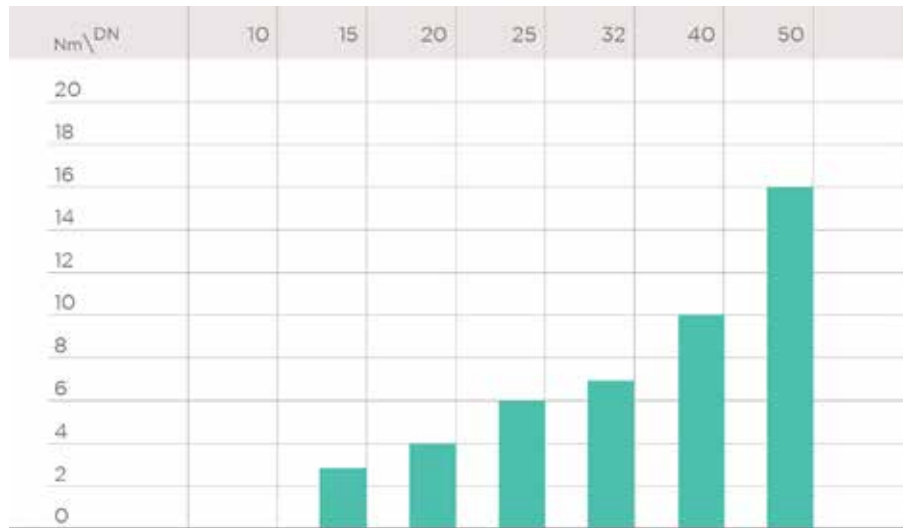

The information in this leaflet is provided in good faith. No liability will be accepted concerning technical data that is not directly covered by recognised international standards. FIP reserves the right to carry out any modification. Products must be installed and maintained by qualified personnel.

# DIMENSIONS

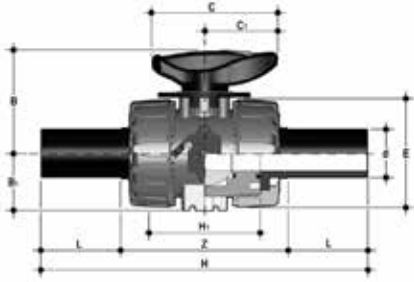

## VKRBEV

Dual Block® regulating ball valve with PE100 SDR 11 male end connectors for butt welding or electrofusion (CVDE)

d	DN	PN	B	B <sub>1</sub>	C	C <sub>1</sub>	E	H	H <sub>1</sub>	L	Z	g	EPDM code
20	15	16	54	29	67	40	54	175	65	40,5	94	220	VKRBEV020E
25	20	16	65	34,5	85	49	65	213	70	54	106	340	VKRBEV025E
32	25	16	69,5	39	85	49	73	228	78	56	117	443	VKRBEV032E
40	32	16	82,5	46	108	64	86	247	88	56	131	693	VKRBEV040E
50	40	16	89	52	108	64	98	271	93	60,5	145	945	VKRBEV050E
63	50	16	108	62	134	76	122	300	111	65,5	161	1607	VKRBEV063E

# ACCESSORIES

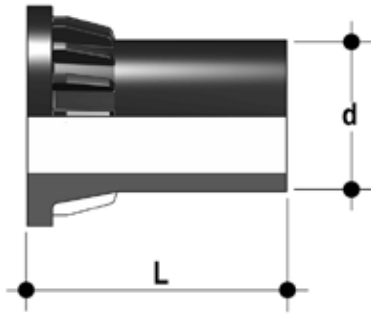

## CVDE

Long spigot PE100 end connectors for joints with electrofusion fittings or for butt welding

d	DN	PN	L	SDR	Code
20	15	16	55	11	CVDE11020
25	20	16	70	11	CVDE11025
32	25	16	74	11	CVDE11032
40	32	16	78	11	CVDE11040
50	40	16	84	11	CVDE11050
63	50	16	91	11	CVDE11063

## PMKD

Wall mounting plate

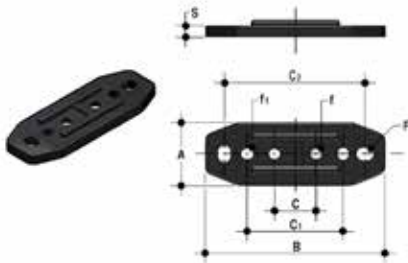

d	DN	A	B	C	C <sub>1</sub>	C <sub>2</sub>	F	f	f <sub>1</sub>	S	Code
20	15	30	86	20	46	67,5	6,5	5,3	5,5	5	PMKD1
25	20	30	86	20	46	67,5	6,5	5,3	5,5	5	PMKD1
32	25	30	86	20	46	67,5	6,5	5,3	5,5	5	PMKD1
40	32	40	122	30	72	102	6,5	6,3	6,5	6	PMKD2
50	40	40	122	30	72	102	6,5	6,3	6,5	6	PMKD2
63	50	40	122	30	72	102	6,5	6,3	6,5	6	PMKD2

## Easytorque Kit

Kit for ball seat carrier tightening adjustment for DUAL BLOCK® DN 10+50 series valves



d	DN	Tightening torque recommended*	Code
1/2"	15	3 N m - 2,21 Lbf ft	KET01
3/4"	20	4 N m - 2,95 Lbf ft	KET01
1"	25	5 N m - 3,69 Lbf ft	KET01
1" 1/4	32	5 N m - 3,69 Lbf ft	KET01
1" 1/2	40	7 N m - 5,16 Lbf ft	KET01
2"	50	9 N m - 6,64 Lbf ft	KET01

\*calculated in ideal installation conditions

# FASTENING AND SUPPORTING

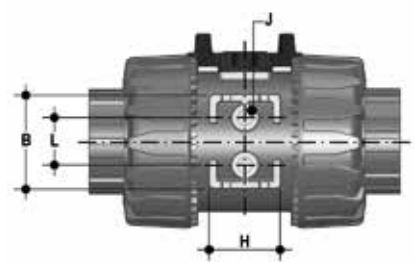

All valves, whether manual or driven, must be adequately supported in many applications.

The VKR valve series is therefore ready to be equipped with threaded supporting brackets (optional) that permits direct anchoring of the valve body without the need of other components.

For wall installation, dedicated PMKD mounting plates which are available as accessories can be used. These plates should be fastened to the valve before wall installation.

PMKD plates also allow VKR valve alignment with FIP ZIKM pipe clips as well as allowing different sizes of valves to be aligned.

d	DN	B	H	L	J*
20	15	31,5	27	20	M4 x 6
25	20	40	30	20	M4 x 6
32	25	40	30	20	M4 x 6
40	32	50	35	30	M6 x 10
50	40	50	35	30	M6 x 10
63	50	60	40	30	M6 x 10

\* With threaded inserts

# COMPONENTS

## EXPLODED VIEW

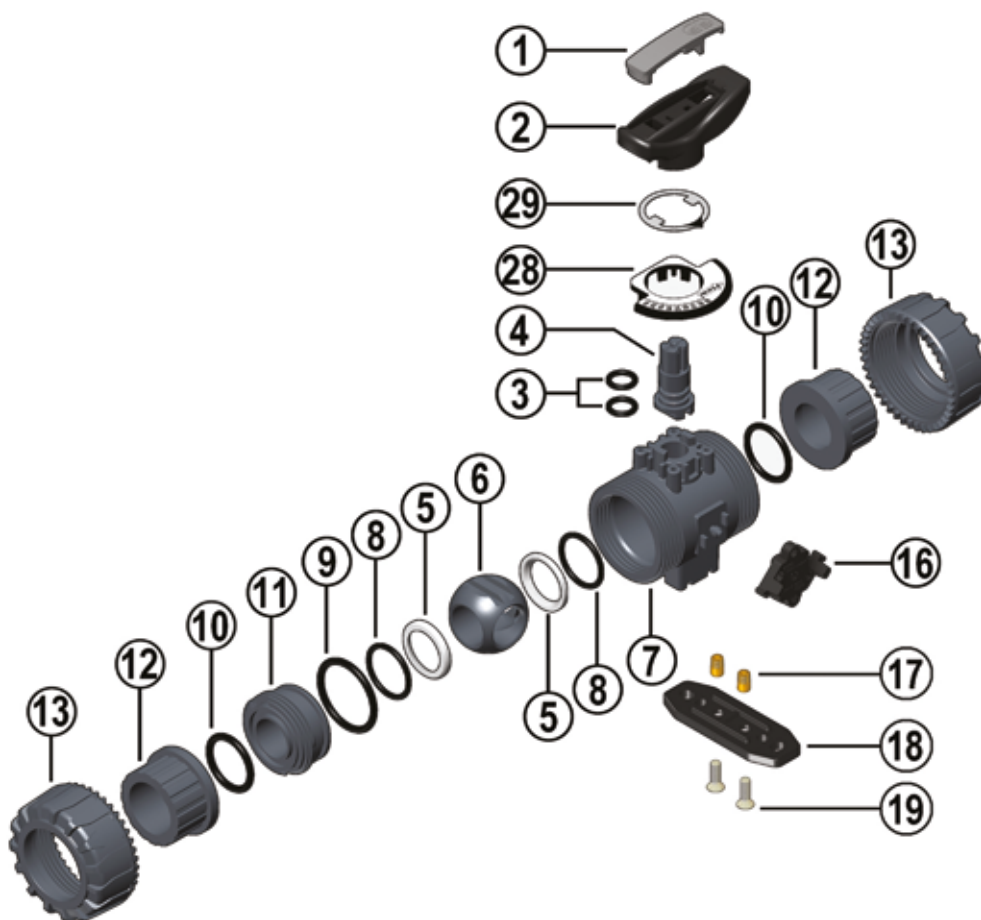

- |          |                                  |           |                                    |           |   |
|----------|----------------------------------|-----------|------------------------------------|-----------|---|
| <b>1</b> | Handle insert (PVC-U - 1)        | <b>8</b>  | Ball seat O-Rings (EPDM-FKM - 2)*  | <b>16</b> | DUAL BLOCK® (POM - 1)                             |
| <b>2</b> | Handle (HIPVC - 1)               | <b>9</b>  | Radial seal O-Ring (EPDM-FKM - 1)* | <b>17</b> | Threaded inserts (STAINLESS steel or Brass - 2)** |
| <b>3</b> | Stem O-ring (EPDM-FKM - 2)*      | <b>10</b> | Socket seal O-Ring (EPDM-FKM - 2)* | <b>18</b> | Distance plate (PP-GR - 1)**                      |
| <b>4</b> | Stem (PVC-U - 1)                 | <b>11</b> | Ball seat carrier (PVC-U - 1)      | <b>19</b> | Screw (STAINLESS steel - 2)**                     |
| <b>5</b> | Ball seat (PTFE - 2)*            | <b>12</b> | End connector (PVC-U - 2)*         | <b>28</b> | Graduated plate (POM-PVC - 1)                     |
| <b>6</b> | Patented ball design (PVC-U - 1) | <b>13</b> | Union nut (PVC-U - 2)              | <b>29</b> | Indicator (PVC - 1)                               |

\* Spare parts

\*\* Accessories

The component material and quantity supplied are indicated in the parentheses.

## DISASSEMBLY

- 1) Isolate the valve from the line (release the pressure and empty the pipeline).
- 2) Unlock the union nuts by pressing the lever on the DUAL BLOCK® (16) along the axis and separate it from the union nut (fig. 1). It is also possible to completely remove the block device from the body of the valve.
- 3) Fully unscrew the union nuts (13) and extract the body sideways.
- 4) Before dismounting, hold the valve in a vertical position and open it 45° to drain any liquid that might remain.
- 5) After closing the valve, remove the special insert (1) from the handle (2) and push the two projecting ends into the corresponding recesses on the ball seat carrier (11). Rotate the stop ring anti-clockwise to extract it.
- 6) Pull the handle (2) upwards to remove it from the valve stem (4).
- 7) Make sure that the position indicator (29) remains properly fastened to the handle (2).
- 8) Press on the ball from the side opposite the "REGULAR - ADJUST" label, being sure not to scratch it, until the ball seat carrier exits (11), then extract the ball (6).
- 9) Press the stem (4) inwards until it exits the valve body.
- 10) All the O-rings (3, 8, 9, 10) and PTFE ball seats (5) must be removed from their grooves, as shown in the exploded view.

## ASSEMBLY

- 1) All the O-rings (3, 8, 9, 10) must be inserted in their grooves as shown in the exploded view.
- 2) Insert the stem (4) from inside the body (7).
- 3) Place the PTFE ball seats (5) in the housings in the body (7) and in the ball seat carrier (11).
- 4) Insert the ball (6) in the body as shown in Fig. 3
- 5) Screw the carrier (11) into the body and tighten up in the clockwise direction using the special insert (1) to limit stop.
- 6) Position the indicator (29) on the handle with the pointer set to 0 on the graduated scale while making sure that the valve is in the closed position (fig. 2-3).
- 7) Insert the handle (2) with the insert (1) in its housing on the stem (4).
- 8) Insert the valve between the end connectors (12) making sure that they match the direction of flow shown on the plate (fig. 2) then tighten the union nuts (13) making sure that the socket seal O-rings (10) do not come out of their grooves.



**Note:** during assembly operations, it is advisable to lubricate the rubber seals. Mineral oils are not recommended for this task as they react aggressively with EPDM rubber.

Fig. 1



Fig. 2



Fig. 3





# INSTALLATION

Before proceeding with installation, please follow these instructions carefully:

- 1) Check that the pipes to be connected to the valve are aligned in order to avoid mechanical stress on the threaded joints.
  - 2) Check that the DUAL BLOCK® union nut locking device (16) is fitted to the valve body.
  - 3) To release the union nuts (13), axially press the release lever to separate the lock and then unscrew it in the counter-clockwise direction.
  - 4) Unscrew the union nuts (13) and insert them on the pipe segments.
  - 5) Solvent weld or screw the end connectors (12) onto the pipe ends.
  - 6) Position the valve between the pipe end connectors making sure the that direction of flow is the same as shown on the plate (Fig.4). Hand tighten the union nuts in the clockwise direction. Do not use a wrench or other tools which might damage the surface.
  - 7) Lock the union nuts by returning the DUAL BLOCK® to its housing, pressing on it until the hinges lock on the nuts.
  - 8) If necessary, support the pipework with FIP pipe clips or by means of the carrier built into the valve itself (see paragraph "fastening and supporting").
- Seals can be adjusted using the removable insert on the handle. The seals can be installed later with the valve installed on the pipe by simply tightening the union nuts. This "micro adjustment", only possible with FIP valves thanks to the patented "Seat stop system", allows the seal to be recovered where PTFE ball seats are worn due to a high number of operations. The Easytorque kit can also be used for micro adjustments (fig. 5).

## WARNINGS

Always avoid sudden closing operations and protect the valve from accidental operations.

Fig. 4



Fig. 5



# VXE DN 15÷50

FIP and Giugiaro Design designed and developed VXE Easyfit, the innovative True Union ball with union nut tightening control that permits simple and safe installation for reliable service in time. This valve is also equipped with the customisable Labelling System.



## EASYFIT 2-WAY BALL VALVE

- **Patented Easyfit system:** innovative mechanism based on the principle of the bevel gear pair that controls valve union nut rotation during installation
- Connection system for solvent weld and threaded joints
- **Valve material compatibility** (PVC-C) and elastomer **seal elements** (EPDM or FKM), with water, drinking water and other food substances as per **current regulations**
- Easy radial disassembly allowing quick replacement of O-rings and ball seats without any need for tools
- **PN16 True Union valve body** made for PVC-C injection moulding and European Directive 2014/68/EU (PED) compliant for pressurised equipment. ISO 9393 compliant test requirements
- Fully interchangeable with previous VX Ergo series models
- Option of disassembling downstream pipes with the valve in the closed position
- Floating **full bore ball** with high surface finish made in CNC work stations to achieve precise dimensional tolerance and high surface finish

### Technical specifications

<b>Construction</b>	Easyfit 2-way True Union ball valve with locked carrier
<b>Size range</b>	DN 15 ÷ 50
<b>Nominal pressure</b>	PN 16 with water at 20 °C
<b>Temperature range</b>	0 °C ÷ 60 °C
<b>Reference standards</b>	<b>Construction criteria:</b> EN ISO 16135, EN ISO 1452, EN ISO 15493 <b>Test methods and requirements:</b> ISO 9393 <b>Installation criteria:</b> DVS 2204, DVS 2221, UNI 11242 <b>Actuator couplings:</b> ISO 5211
<b>Valve material</b>	PVC-U
<b>Seal material</b>	EPDM (standard size O-Ring); PTFE (ball seats)
<b>Control options</b>	Manual control

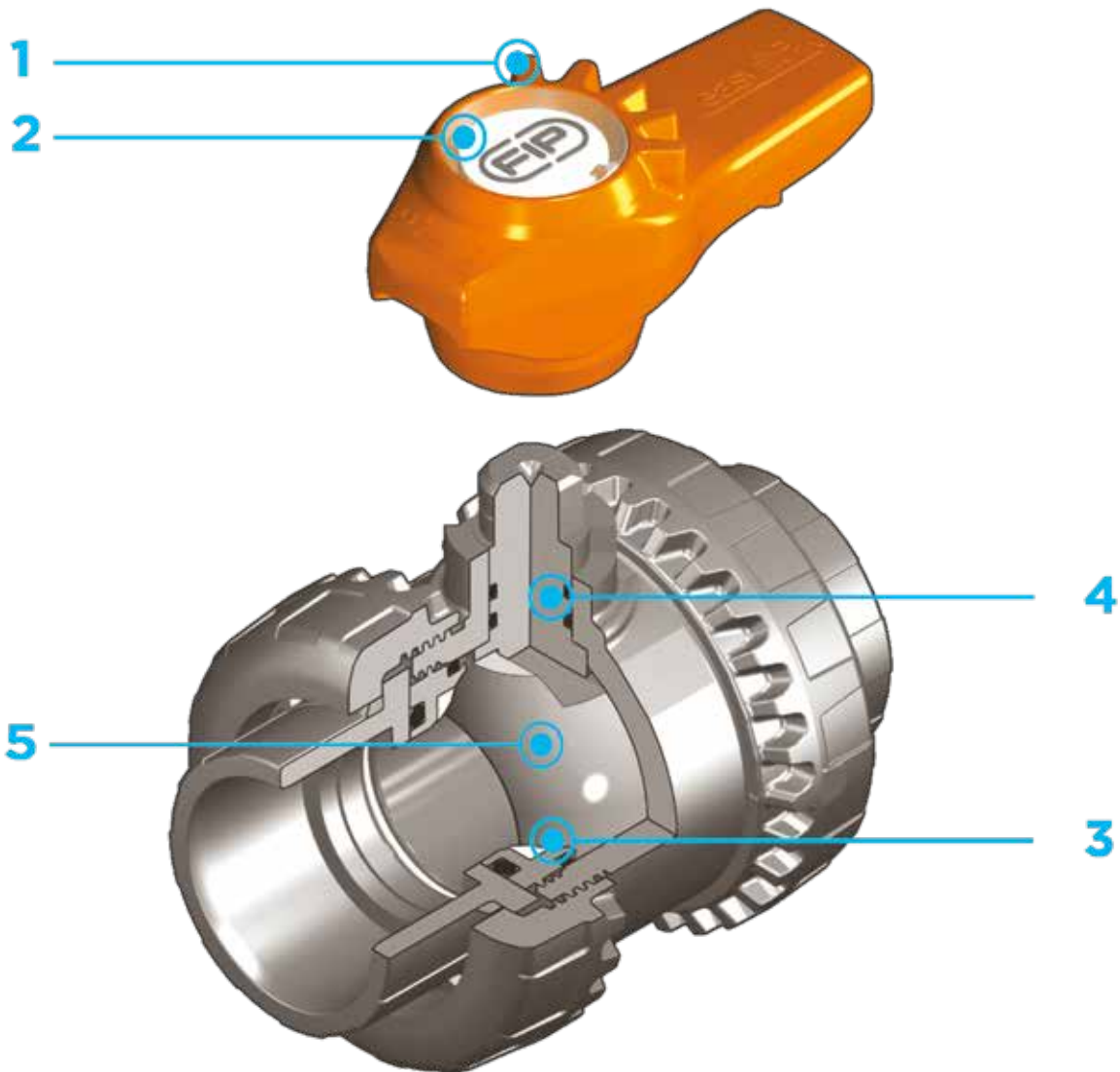

**1** Two position **Easyfit ergonomic multifunctional handle with union nut tightening control** which can be used to **adjust ball seat carriers**. Handle use is especially indicated for **maintenance** work where **space is limited** and hard to access

**2** **Customisable Labelling System: built-in LCE module** on the handle made up of a transparent

protection plug and customisable tag holder with LSE set (available as accessory). The customisation potential lets you **identify the valve on the system** according to specific needs

**3** **The PTFE ball seat system with locked carrier** adjustable via Easyfit multifunctional handle or Easytorque adjustment kit (available as an accessory)

**4** High surface finish **valve stem with double O-Ring**, produced in CNC work stations to achieve precise dimensional tolerance and increased reliability

**5** Machined high surface finish ball that guarantees a smooth operation and increased reliability

# TECHNICAL DATA

## PRESSURE VARIATION ACCORDING TO TEMPERATURE

For water and harmless fluids to which the material is classified as CHEMICALLY RESISTANT. In other cases, a reduction of the nominal PN pressure is required (25 years with safety factor).



## PRESSURE DROP GRAPH

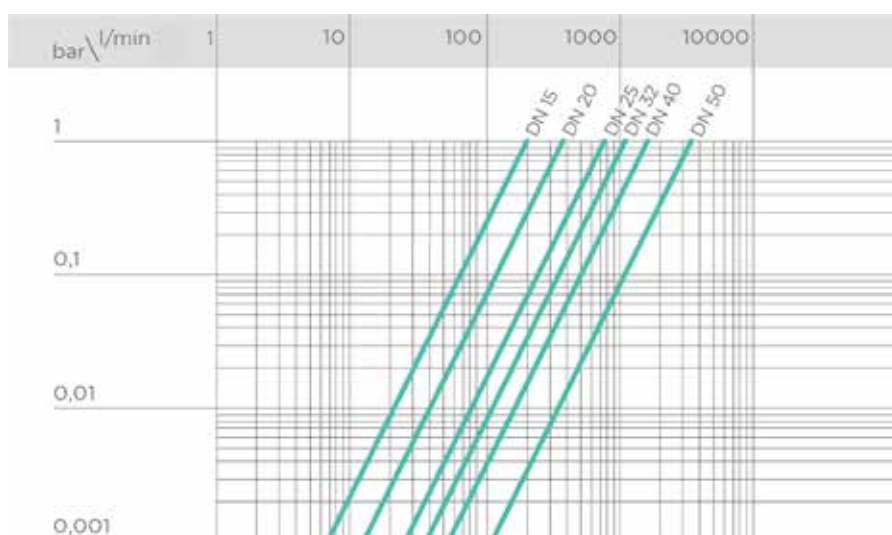

## K<sub>v</sub>100 FLOW COEFFICIENT

The K<sub>v</sub>100 flow coefficient is the Q flow rate of litres per minute of water at a temperature of 20°C that will generate Δp= 1 bar pressure drop at a certain valve position. The Kv100 values shown in the table are calculated with the valve completely open.

DN	15	20	25	32	40	50
K <sub>v</sub> 100 l/min	200	385	770	1110	1750	3400

The information in this leaflet is provided in good faith. No liability will be accepted concerning technical data that is not directly covered by recognised international standards. FIP reserves the right to carry out any modification. Products must be installed and maintained by qualified personnel.

# ACCESSORIES

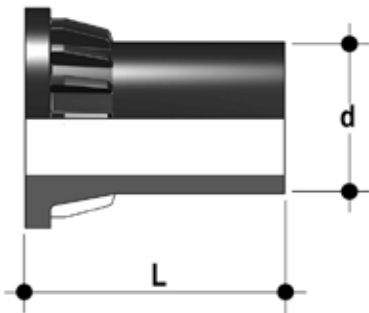

## CVDE

Long spigot PE100 end connectors for joints with electrofusion fittings or for butt welding

d	DN	PN	L	SDR	Code
20	15	16	55	11	CVDE11020
25	20	16	70	11	CVDE11025
32	25	16	74	11	CVDE11032
40	32	16	78	11	CVDE11040
50	40	16	84	11	CVDE11050
63	50	16	91	11	CVDE11063



## EASYTORQUE KIT

Kit for union nut tightening adjustment and ball seat carrier for Easyfit DN 10÷50 valves.

d	DN	Union nut tightening torque*	Seat carrier tightening torque*	Code
1/2"	15	5 N m - 3,69 Lbf ft	3 N m - 2,21 Lbf ft	KET01
3/4"	20	5 N m - 3,69 Lbf ft	3 N m - 2,21 Lbf ft	KET01
1"	25	6 N m - 4,43 Lbf ft	4 N m - 2,95 Lbf ft	KET01
1" 1/4	32	7 N m - 5,16 Lbf ft	4 N m - 2,95 Lbf ft	KET01
1" 1/2	40	8 N m - 5,90 Lbf ft	5 N m - 3,69 Lbf ft	KET01
2"	50	10 N m - 7,38 Lbf ft	6 N m - 4,43 Lbf ft	KET01

\*calculated in ideal installation conditions



## LCE

Transparent protection plug with tag holder

d	DN	VEE code
20	15	LCE020
25	20	LCE025
32	25	LCE032
40	32	LCE040
50	40	LCE050
63	50	LCE063



## LSE

Customisation and label printing set for Easyfit handle made up of pre-cut adhesive sheets and software for guided label creation.

d	DN	VEE-VXE code
20	15	LSE020
25	20	LSE025
32	25	LSE032
40	32	LSE040
50	40	LSE050
63	50	LSE063

# ACCESSORIES

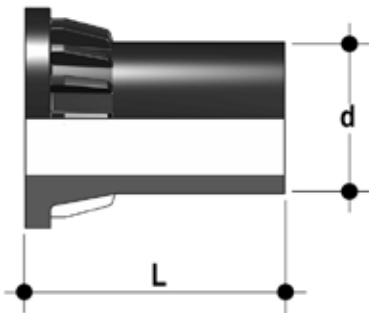

## CVDE

Long spigot PE100 end connectors for joints with electrofusion fittings or for butt welding

d	DN	PN	L	SDR	Code
20	15	16	55	11	CVDE11020
25	20	16	70	11	CVDE11025
32	25	16	74	11	CVDE11032
40	32	16	78	11	CVDE11040
50	40	16	84	11	CVDE11050
63	50	16	91	11	CVDE11063



## EASYTORQUE KIT

Kit for union nut tightening adjustment and ball seat carrier for Easyfit DN 10÷50 valves.

d	DN	Union nut tightening torque*	Seat carrier tightening torque*	Code
1/2"	15	5 N m - 3,69 Lbf ft	3 N m - 2,21 Lbf ft	KET01
3/4"	20	5 N m - 3,69 Lbf ft	3 N m - 2,21 Lbf ft	KET01
1"	25	6 N m - 4,43 Lbf ft	4 N m - 2,95 Lbf ft	KET01
1" 1/4	32	7 N m - 5,16 Lbf ft	4 N m - 2,95 Lbf ft	KET01
1" 1/2	40	8 N m - 5,90 Lbf ft	5 N m - 3,69 Lbf ft	KET01
2"	50	10 N m - 7,38 Lbf ft	6 N m - 4,43 Lbf ft	KET01

\*calculated in ideal installation conditions



## LCE

Transparent protection plug with tag holder

d	DN	VEE code
20	15	LCE020
25	20	LCE025
32	25	LCE032
40	32	LCE040
50	40	LCE050
63	50	LCE063



## LSE

Customisation and label printing set for Easyfit handle made up of pre-cut adhesive sheets and software for guided label creation.

d	DN	VEE-VXE code
20	15	LSE020
25	20	LSE025
32	25	LSE032
40	32	LSE040
50	40	LSE050
63	50	LSE063

# CUSTOMISATION

Fig. 1



Fig. 2



Fig. 3

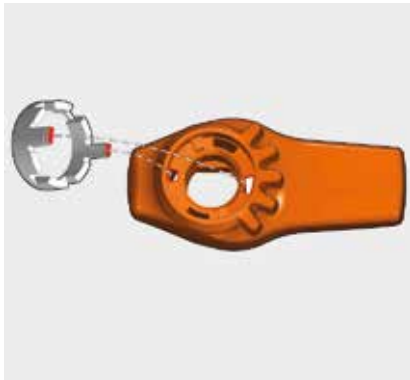

The VXE DN 15÷50 Easyfit valve is equipped with the customisable Labelling System.

This system lets you create special labels to insert in the handle. This makes it extremely easy to apply company logos, identification serial numbers or service indications such as, for example, the valve function in the system, the transported fluid, but also specific information for customer service, such as the customer name or installation date or location on the valves.

The specific LCE module is a standard supply and is made up of a rigid transparent water-resistant PVC plug (A) and white tag holder (B) made of the same material, one side of which bears the FIP logo (fig. 1).

The holder, inserted in the plug, can be removed and, once overturned, used for customisation by applying labels printed with the software supplied with the LSE set.

Proceed as follows to apply the label on the valve:

- 1) Extract the handle from the valve body and extract the transparent plug.
- 2) Extract the tag holder from the transparent plug (fig. 2).
- 3) Apply the adhesive label on the tag holder to align the profiles matching the tab position.
- 4) Re-insert the tag holder in the transparent plug so that the label is protected from the elements.
- 5) Apply the transparent plug on the handle matching the two fittings (one narrow and one wide) with their housings (fig. 3).

# COMPONENTS

## EXPLODED VIEW

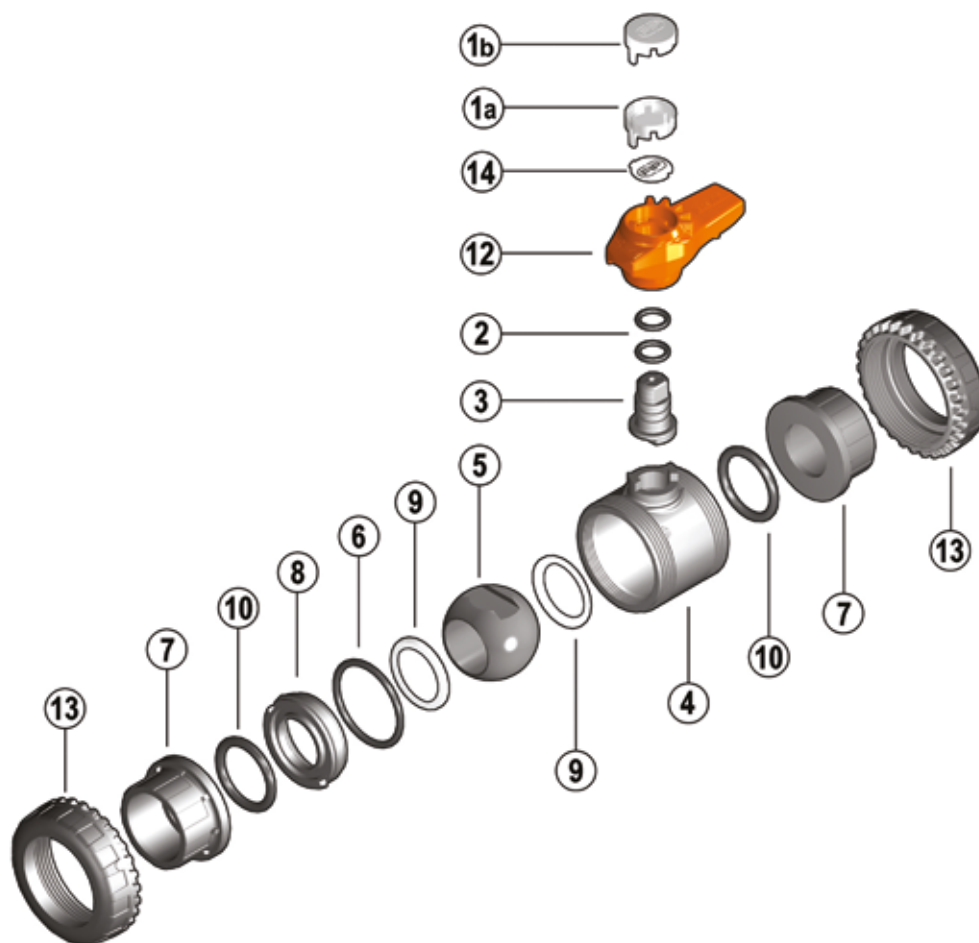

**1a** Transparent protection plug (PVC - 1)

**2** Stem O-rings (EPDM-FKM - 2)\*

**3** Stem (PVC-U - 1)

**4** Body (PVC-U - 1)

**5** Ball (PVC-U - 1)

**6** Radial seal O-Ring (EPDM-FKM - 1)\*

**7** End connector (PVC-U - 2)

**8** Ball seat carrier (PVC-U - 1)

**9** Ball seat (PTFE - 2)\*

**10** Socket seal O-Ring (EPDM-FKM - 2)\*

**12** Handle (HIPVC - 1)

**13** Union nut (PVC-U - 2)

**14** Tag holder (PVC-U - 1)

\* Spare parts

The component material and quantity supplied are indicated in the parentheses.



## DISASSEMBLY

- 1) Isolate the valve from the line (release the pressure and empty the pipeline).
- 2) Fully unscrew the union nuts (13) from the valve body and slide the body out sideways (fig. 4-5). To do this, we recommend you use the Easyfit handle as a tool (fig. 8-9)
- 3) Before dismounting, hold the valve in a vertical position and open it 45° to drain any liquid that might remain.
- 4) After closing the valve, remove the handle (12) (fig. 6) and insert the two protrusions in the lower side in the two apertures and in the carrier passage bore (8) extracting it by turning counter-clockwise (fig. 7).
- 5) Press on the ball from the side opposite the "REGULAR" label, being sure not to scratch it, until the ball seat exits (9), then extract the ball (5).
- 6) Press the stem (3) inwards until it exits the body.
- 7) Remove the O-Rings (2, 6, 10) and ball seats (9) extracting them from their seats, as illustrated in the exploded view.

## ASSEMBLY

- 1) All the O-Rings (2, 6, 10) must be inserted in their grooves as shown in the exploded view.
- 2) Insert the stem (3) from inside the body (4).
- 3) Place the ball seats (9) in the housings in the body (4) and in the carrier (8).
- 4) Insert the ball (5) rotating it to the closed position.
- 5) Screw the carrier (8) into the body and tighten up in the clockwise direction using the handle (12) to limit stop.
- 6) Position the valve between the end connectors (7) and tighten the union nuts (13) clockwise using the Easyfit multifunctional handle, being sure the socket seal O-Rings (10) do not exit the seats.
- 7) Position the handle (12) on the stem (3).



**Note:** during assembly operations, it is advisable to lubricate the rubber seals. Mineral oils are not recommended for this task as they react aggressively with EPDM rubber.

Fig. 4



Fig. 5



Fig. 6



Fig. 7



# INSTALLATION

Before proceeding with installation, please follow these instructions carefully:

- 1) Check that the pipes to be connected to the valve are aligned in order to avoid mechanical stress on the threaded joints.
- 2) Unscrew the union nuts from the valve body (4) and slide them onto the pipe.
- 3) Solvent weld or screw the end connectors (7) onto the pipe segments.
- 4) Position the valve body between the end connectors (fig. 5). Warning: if a high pressure test is required, always position the body with the "REGULAR" label upstream from the fluid direction.
- 5) Fit the union nuts on the valve body and manually tighten clockwise until they become hard to turn; do not use wrenches or other tools that can damage the union nut surfaces.
- 6) Extract the handle (12) from the valve body and extract the transparent plug (1a).
- 7) Overturn the handle and insert it on the valve stem matching the handle teeth (A) with the union nut teeth (B) (fig. 8-9).
- 8) Turn the handle counter-clockwise to fully tighten the union nut. The rotation directions to tighten (TIGHTEN) and loosen (UNTIGHTEN) the union nuts are indicated on the handle (fig. 10). Generally, if pipes are not offset, one turn is sufficient for correct tightening.
- 9) Repeat point 7 for the other union nut. Note: A small force applied on the handle develops a torque much higher than manual tightening. You can also, using the Easytorque kit (fig. 11), supplied as an accessory, tighten union nuts using a torque wrench to quantify the force and thus monitor the stress applied to the thermoplastic threads according to the installation indications in the instructions enclosed with the kit.
- 10) Apply the plug (1a) on the handle (12) matching the two fittings (one narrow and one wide) with the relevant housings on the handle (fig. 3).
- 11) Install the handle (12) on the stem (3) again.
- 12) If necessary, support the pipe with FIP pipe clip model ZIKM and DSM distance plates.

## WARNINGS

If volatile liquid such as Hydrogen Peroxide (H<sub>2</sub>O<sub>2</sub>) or Sodium Hypochlorite (NaClO) is used, for safety reasons we recommend you contact the service centre. These liquids, upon vaporising, could create hazardous over pressures in the area between the body and ball.

Do not use compressed air or other gases to test thermoplastic lines.

Always avoid sudden closing manoeuvres and protect the valve from accidental manoeuvres.

Fig. 8



Fig. 9



Fig. 10



Fig. 11





# VXE DN 65÷100

FIP and Giugiaro Design designed and developed VXE Easyfit, the innovative True Union ball valve with union nut tightening control system that permits simple and safe installation for reliable service in time. This valve is also equipped with the customisable Labelling System.



## EASYFIT 2-WAY BALL VALVE

- **Patented Easyfit system:** innovative mechanism based on the multifunctional handle quick release mechanism that permits union nut rotation during valve installation and ball carrier adjustment
- Connection system for solvent weld and threaded joints
- **Valve material compatibility** (PVC-U) and elastomer **seal elements** (EPDM or FKM), with water, drinking water and other food substances as per **current regulations**
- Easy radial dismounting allowing quick replacement of O-rings and ball seats without any need for tools
- **PN16 True Union valve body** made for PVC-U injection moulding and European Directive 2014/68/EU (PED) compliant for pressurised equipment. ISO 9393 compliant test requirements
- Valve body with built in anchoring frame for the special **Power Quick module** dedicated to accessory or pneumatic and electric actuator installation
- Option of dismounting downstream pipes with the valve in the closed position
- Floating **full bore ball** with high surface finish made in CNC work stations to achieve precise dimensional tolerance and high surface finish

### Technical specifications

<b>Construction</b>	Easyfit 2-way True Union ball valve with locked carrier
<b>Size range</b>	DN 65 ÷ 100
<b>Nominal pressure</b>	PN 16 with water at 20 °C
<b>Temperature range</b>	0 °C ÷ 60 °C
<b>Reference standards</b>	<b>Construction criteria:</b> EN ISO 16135, EN ISO 1452, EN ISO 15493 <b>Test methods and requirements:</b> ISO 9393 <b>Installation criteria:</b> DVS 2204, DVS 2221, UNI 11242 <b>Actuator couplings:</b> ISO 5211
<b>Valve material</b>	PVC-U
<b>Seal material</b>	EPDM (standard size O-Ring); PTFE (ball seats); PE
<b>Control options</b>	Manual control, electric actuator, pneumatic actuator

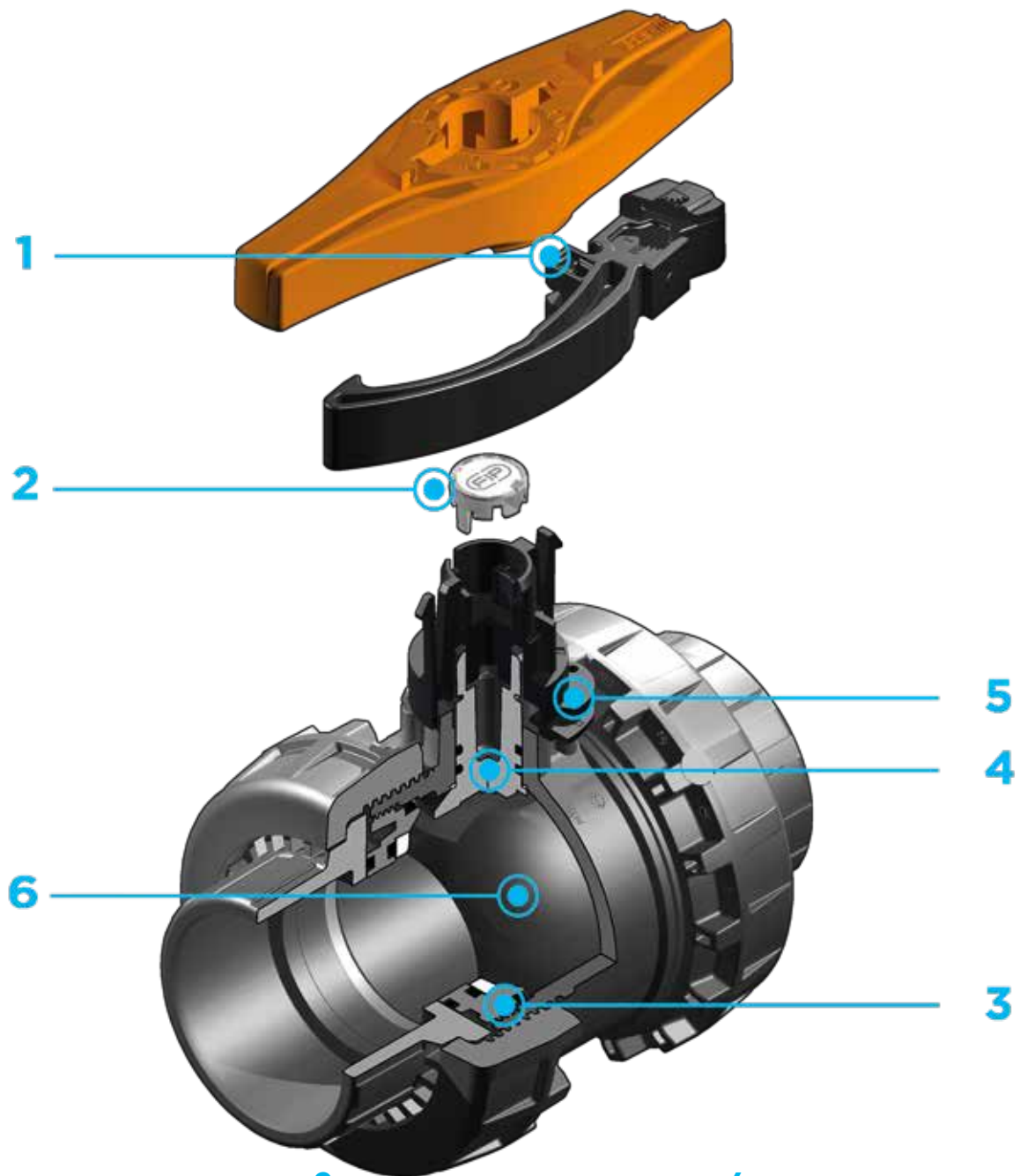

**1** Innovative Easyfit quick release handle made up of a central hub firmly coupled with the stem valve and dual spoke grip that can be released from the hub with a simple operation and used as a ball seat adjustment tool and as a union nut tightening tool thanks to the hooked insert that, perfectly adapting to their external profile, allows the handle to transform into a wrench to control union nut rotation

**2** Customisable Labelling System: built-in LCE module in the hub made up of transparent protection plug and customisable tag holder using the LSE set (available as accessory). The customisation potential lets you identify the valve on the system according to specific needs

**3** PTFE ball seat system with locked carrier adjustable via the Easyfit quick release handle

**4** Stem with high surface finish and double O-Ring and PTFE antifriction disk that limits friction to a minimum and grants excellent operating torque

**5** Locking device in closing and opening via lock

**6** Machined high surface finish ball that guarantees a smooth operation and increased reliability

# TECHNICAL DATA

## PRESSURE VARIATION ACCORDING TO TEMPERATURE

For water and harmless fluids to which the material is classified as CHEMICALLY RESISTANT. In other cases, a reduction of the nominal PN pressure is required (25 years with safety factor).



## PRESSURE DROP GRAPH

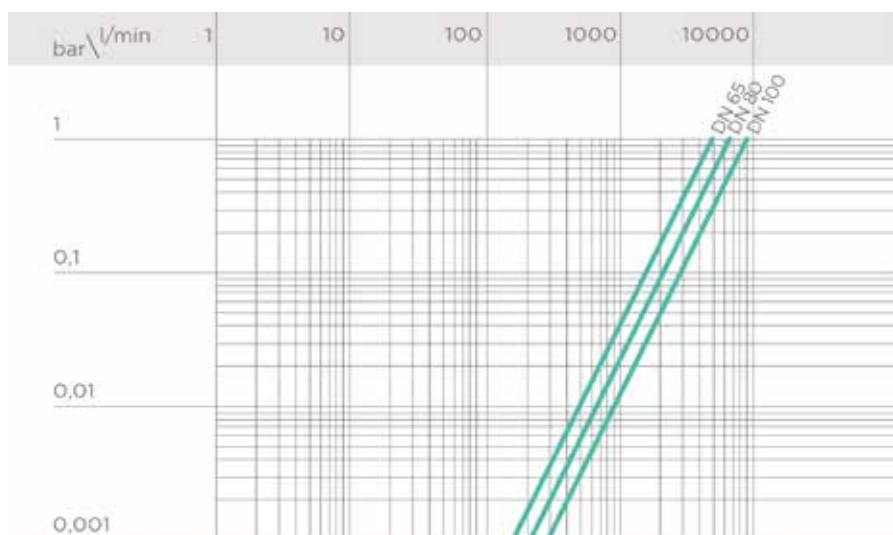

## K<sub>v</sub>100 FLOW COEFFICIENT

The K<sub>v</sub>100 flow coefficient is the Q flow rate of litres per minute of water at a temperature of 20°C that will generate Δp= 1 bar pressure drop at a certain valve position. The Kv100 values shown in the table are calculated with the valve completely open.

DN	65	80	100
K <sub>v</sub> 100 l/min	5000	7000	9400

## OPERATING TORQUE AT MAXIMUM WORKING PRESSURE

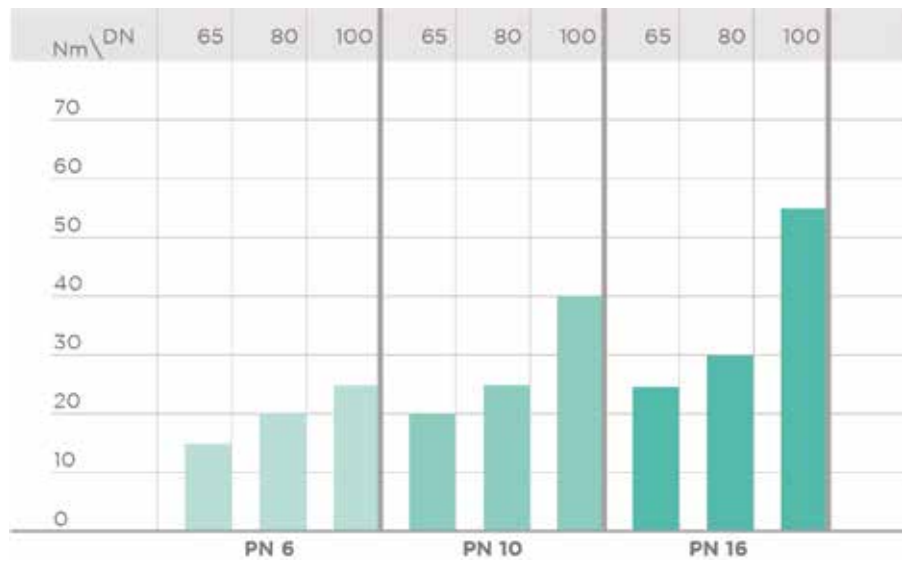

The information in this leaflet is provided in good faith. No liability will be accepted concerning technical data that is not directly covered by recognised international standards. FIP reserves the right to carry out any modification. Products must be installed and maintained by qualified personnel.

# DIMENSIONS



## VXEBEV

Easyfit 2-way ball valve with PE100 SDR 11 male connectors for butt welding or electrofusion (CVDE)

d	DN	PN	B	C	C <sub>1</sub>	E	H	L	Z	g	PTFE - EPDM code	PE - EPDM code
75	65	16	141,5	214	115	157	331	71	189	2286	VXEBEV075E	VXEBEV075M
90	80	10	151	239	126	174	367	88	191	3059	VXEBEV090E	VXEBEV090M
110	100	10	174,5	270	145	212	407	92	223	5814	VXEBEV110E	VXEBEV110M



# ACCESSORIES

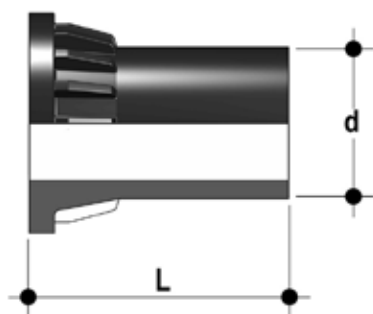

## CVDE

Long spigot PE100 end connectors for joints with electrofusion fittings or for butt welding

d	DN	PN	L	SDR	Code
75	65	16	111	11	CVDE11075
90	80	16	118	11	CVDE11090VXE
110	100	16	127	11	CVDE11110VXE

## PSE

Stem extension

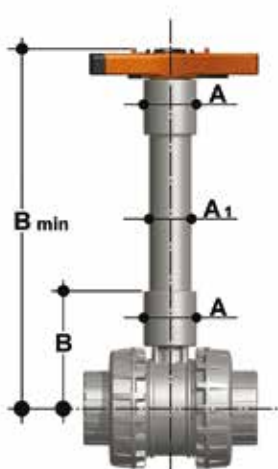

d	inch	DN	A	A <sub>1</sub>	B	B min	ISO pipe code	ASTM-BS pipe code
75	2 1/2	65	76	63	159	364	PSE090	PSE300
90	3"	80	76	63	166	371	PSE090	PSE300
110	4"	100	76	63	186	433	PSE110	PSE400

## LCE

Transparent protection plug with tag holder



d	DN	VEE code
75	65	LCE040
90	80	LCE040
110	100	LCE040



## LSE

Customisation and label printing set for Easyfit handle made up of precut adhesive sheets and software for guided label creation.

d	DN	VXE - VEE code
75	65	LSE040
90	80	LSE040
110	100	LSE040

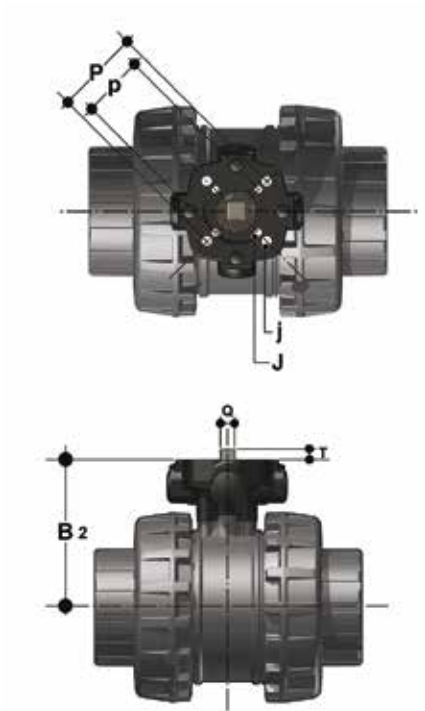

## Power Quick Easyfit

The valve can be equipped with pneumatic or electric standard actuators and gearbox for heavy-duty operations, using the PP-GR module reproducing the drilling pattern foreseen by ISO 5211.

d	DN	B <sub>2</sub>	Q	T	p x j	P x J	Code
75	65	129	14	16	F05 x 6,5	F07 x 8,5	PQE090
90	80	136	14	16	F05 x 6,5	F07 x 8,5	PQE090
110	100	156	17	19	F05 x 6,5	F07 x 8,5	PQE110

# CUSTOMISATION

Fig. 1



Fig. 2



The VXE DN 65÷100 Easyfit valve is equipped with the customisable Labelling System.

This system lets you create special labels to insert in the handle. This makes it extremely easy to apply company logos, identification serial numbers or service indications such as, for example, the valve function in the system, the transported fluid, but also specific information for customer service, such as the customer name or installation date or location on the valves.

The specific LCE module is a standard supply and is made up of a rigid transparent water-resistant PVC plug (A) and white tag holder (B) made of the same material, one side of which bears the FIP logo (fig. 1).

The holder, inserted in the plug, can be removed and, once overturned, used for customisation by applying labels printed with the software supplied with the LSE set.

Proceed as follows to apply the label on the valve:

- 1) Release the handle from the central hub (C) and extract the transparent plug.
- 2) Extract the tag holder from the transparent plug (fig. 2).
- 3) Apply the adhesive label on the tag holder to align the profiles matching the tab position.
- 4) Re-insert the tag holder in the transparent plug so that the label is protected from the elements.
- 5) Apply the transparent plug on the central hub matching the two fittings (one narrow and one wide) with the relevant housings.

# COMPONENTS

## EXPLODED VIEW

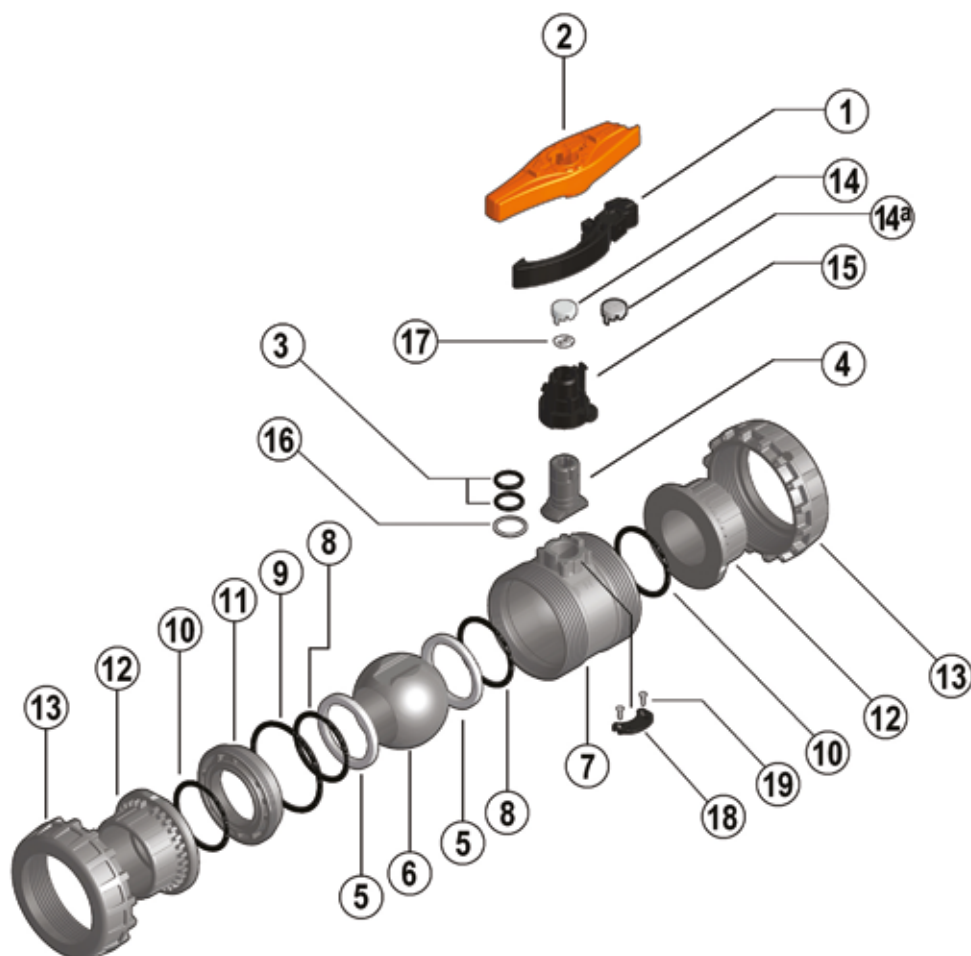

- |          |  |           |                                       |            |   |
|----------|--|-----------|---------------------------------------|------------|---|
| <b>1</b> | Hooked Easyfit multifunctional handle insert (PP-GR - 1) | <b>8</b>  | Ball seat O-Ring (FKM, EPDM** - 2)*   | <b>14</b>  | Transparent protection plug (PVC - 1)             |
| <b>2</b> | Easyfit multifunctional handle (HIPVC - 1)               | <b>9</b>  | Radial seal O-Ring (FKM, EPDM** - 1)* | <b>14a</b> | Grey protection plug for VXE-PE version (PVC - 1) |
| <b>3</b> | Stem O-rings (FKM, EPDM** - 2)*                          | <b>10</b> | Socket seal O-Ring (EPDM-FKM - 2)*    | <b>15</b>  | Central hub (HIPVC - 1)                           |
| <b>4</b> | Stem (PVC-U - 1)   | <b>11</b> | Ball seat carrier (PVC-U - 1)         | <b>16</b>  | Anti-friction disk (PTFE - 1)*                    |
| <b>5</b> | Ball seat (PTFE, PE** - 2)*                              | <b>12</b> | End connector (PVC-U - 2)             | <b>17</b>  | Tag holder (PVC-U - 1)                            |
| <b>6</b> | Ball (PVC-U - 1)*  | <b>13</b> | Union nut (PVC-U - 2)                 | <b>18</b>  | Locking device plate (HIPVC - 1)                  |
| <b>7</b> | Body (PVC-U - 1)   |           |                                       | <b>19</b>  | Self-tapping screw (STAINLESS steel - 2)          |

\* Spare parts

\*\* For the VXE-PE version: EPDM O-ring (3, 8, 9, 10), PE ball seat (5)

The component material and quantity supplied are indicated in the parentheses.

## DISASSEMBLY

- 1) Isolate the valve from the line (release the pressure and empty the pipeline).
- 2) Extract the Easyfit multifunctional handle from the central hub pressing on the centre of the hub hinges (fig. 5) and use it as a wrench to fully unscrew the union nuts (13) from the valve body and slide the body out sideways (fig. 5).
- 3) Reposition the handle on the central hub.
- 4) Before dismounting, hold the valve in a vertical position and open it 45° to drain any liquid that might remain.
- 5) Open the valve.
- 6) Remove the ball seat carrier (11) using the Easyfit quick release handle. Insert the two protrusions at the top of the handle in the seat carriers (11) and unscrew, extracting it by turning counter-clockwise (fig. 6).
- 7) Press on the ball from the side opposite the "REGULAR" label, being sure not to scratch it, until the ball seat exits (5), then extract the ball (6).
- 8) Remove the central hub (15) firmly sliding it off the stem (4). Press the stem inwards and extract it from the body and remove the anti-friction disk (16).
- 9) Remove the O-Ring (3, 8, 9, 10) and ball seats (5) extracting them from their seats, as illustrated in the exploded view.

## ASSEMBLY

- 1) All the O-rings (3, 8, 9, 10) must be inserted in their grooves as shown in the exploded view.
- 2) Place the anti-friction disk (16) on the stem (4) and insert it in the body (7).
- 3) Place the ball seats (5) in the housings in the body (7) and in the carrier (11).
- 4) Insert the ball (6) rotating it to the closed position.
- 5) Screw the carrier (11) into the body and tighten up in the clockwise direction using the handle (2) to limit stop.
- 6) Place the central hub (15) on the stem (4) firmly pressing down to match the internal hub key with one of the two seats on the stem.
- 7) Position the valve between the end connectors (12) and tighten the union nuts clockwise (13) using the Easyfit multifunctional handle (fig. 9) and being sure the socket seal O-rings (10) do not exit the seats.
- 8) Re-insert the hooked insert (1) in the housing on the handle (2).
- 9) Reposition the handle on the central hub making sure the two grooves in the central handle bore match the two grooves on the side of the hub and slightly press down until the two hinges click.



**Note:** during assembly operations, it is advisable to lubricate the rubber seals. Mineral oils are not recommended for this task as they react aggressively with EPDM rubber.

Fig. 3



Fig. 4



Fig. 5



Fig. 6



# INSTALLATION

Before proceeding with installation, please follow these instructions carefully:

- 1) Check that the pipes to be connected to the valve are aligned in order to avoid mechanical stress on the threaded joints.
  - 2) Unscrew the union nuts (13) from the body (7) and insert them in the pipe segments.
  - 3) Solvent weld or screw the end connectors (12) onto the pipe segments.
  - 4) Position the valve body between the end connectors. Warning: if a high pressure test is required, always position the body with the "REGULAR" label upstream from the fluid direction.
  - 5) Place the union nuts on the valve body and start tightening manually clockwise until they are hard to turn. To complete tightening, extract the Easyfit quick release multifunctional handle (2) pushing on the centre of the central hub hinges (15) (fig. 3 and 4)
  - 6) Extract the hooked insert (1) in the handle (fig. 7) overturn it and fit it in the seat on the lower part of the handle (fig. 8).
  - 7) Fit the tool (fig. 8) on the external union nut profile until firmly and safely secured, allowing for adequate torque without damaging the union nut in any way (fig. 9).
  - 8) Repeat point 7 for the other union nut.
  - 9) When tightened, remove the hooked insert and replace it in its seat in the handle.
  - 10) Reposition the handle on the central hub making sure the two grooves in the central handle bore match the two grooves on the side of the hub and slightly press down until the two hinges click.
  - 11) If necessary, support the pipe with FIP pipe clip model ZIKM and DSM distance plates.
- The VXE valve is equipped with a locking device to protect the system against tampering (fig. 10).

## WARNINGS

If volatile liquid such as Hydrogen Peroxide (H<sub>2</sub>O<sub>2</sub>) or Sodium Hypochlorite (NaClO) are used, for safety reasons we recommend you contact the service centre. These liquids, upon vaporising, could create hazardous over pressures in the area between the body and ball.

Always avoid sudden closing manoeuvres and protect the valve from accidental manoeuvres.

Fig. 7



Fig. 8



Fig. 9



Fig. 10





# VEE DN 15÷50

FIP and Giugiaro Design designed and developed VEE Easyfit, the innovative True Union ball valve with union nut tightening control, that permits simple and safe installation for reliable service in time.

The valve is specifically designed for water conveyance applications.



## EASYFIT 2-WAY BALL VALVE

- **Patented Easyfit system:** innovative mechanism based on the principle of the bevel gear pair that controls valve union nut rotation during installation.
- Connection system for solvent weld and threaded joints
- **Valve material compatibility** (PVC-U) with water, drinking water and other food substance conveyance according to **current regulations**
- Easy radial dismounting allowing quick replacement of O-rings and ball seats without any need for tools
- **PN16 True Union valve body** made for PVC-U injection moulding and European Directive 2014/68/EU (PED) compliant for pressurised equipment. ISO 9393 compliant test requirements
- Fully interchangeable with previous VE series models
- Option of dismounting downstream pipes with the valve in the closed position
- Floating full bore ball with high surface finish made in CNC work stations to achieve precise dimensional tolerance and high surface finish

### Technical specifications

<b>Construction</b>	Easyfit 2-way True Union ball valve with locked carrier
<b>Size range</b>	DN 15 ÷ 50
<b>Nominal pressure</b>	PN 16 with water at 20 °C
<b>Temperature range</b>	0 °C ÷ 60 °C
<b>Reference standards</b>	<b>Construction criteria:</b> EN ISO 16135, EN ISO 1452, EN ISO 15493 <b>Test methods and requirements:</b> ISO 9393 <b>Installation criteria:</b> DVS 2204, DVS 2221, UNI 11242 <b>Actuator couplings:</b> ISO 5211
<b>Valve material</b>	PVC-U
<b>Seal material</b>	EPDM (standard size O-Ring); PE (ball seats)
<b>Control options</b>	Manual control



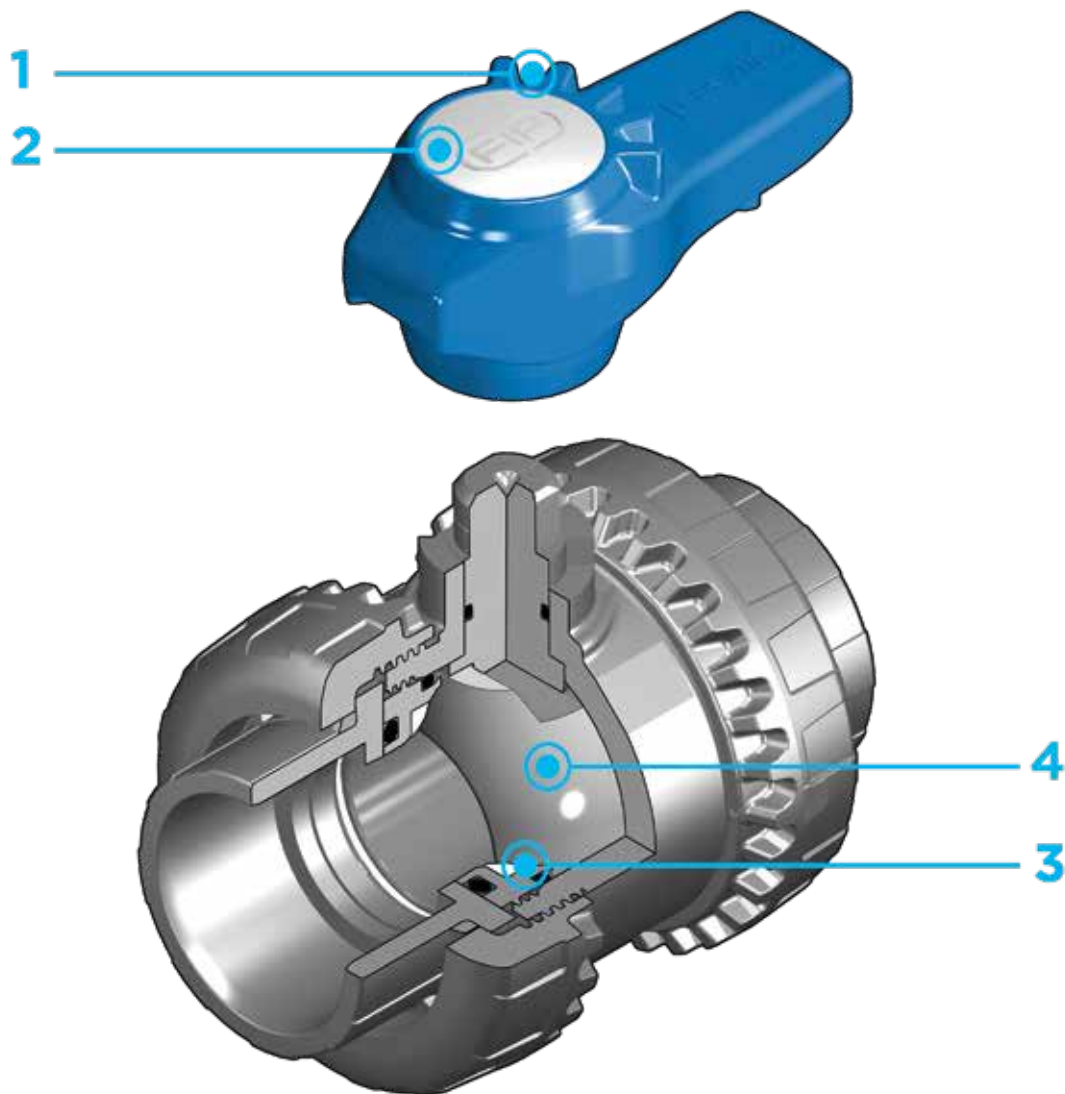

- 1 Two position **Easyfit ergonomic multifunctional handle with union nut tightening control which can be used to adjust ball seat carriers**. Handle use is especially indicated for **maintenance** work where **space is limited** and hard to access
- 2 Settings for the customisable

Labelling System using the LCE module (available as an accessory). The grey protection plug housed on the handle can be replaced with the transparent plug and customisable tag holder with the LSE set (available as an accessory). The **customisation** lets you **identify the valve on the system** according to specific needs

- 3 **The PE ball seat system with locked carrier** adjustable via Easyfit multifunctional handle or Easytorque adjustment kit (available as an accessory)
- 4 Machined high surface finish ball that guarantees a smooth operation and increased reliability

# TECHNICAL DATA

## PRESSURE VARIATION ACCORDING TO TEMPERATURE

For water and harmless fluids to which the material is classified as CHEMICALLY RESISTANT. In other cases, a reduction of the nominal PN pressure is required (25 years with safety factor).



## PRESSURE DROP GRAPH

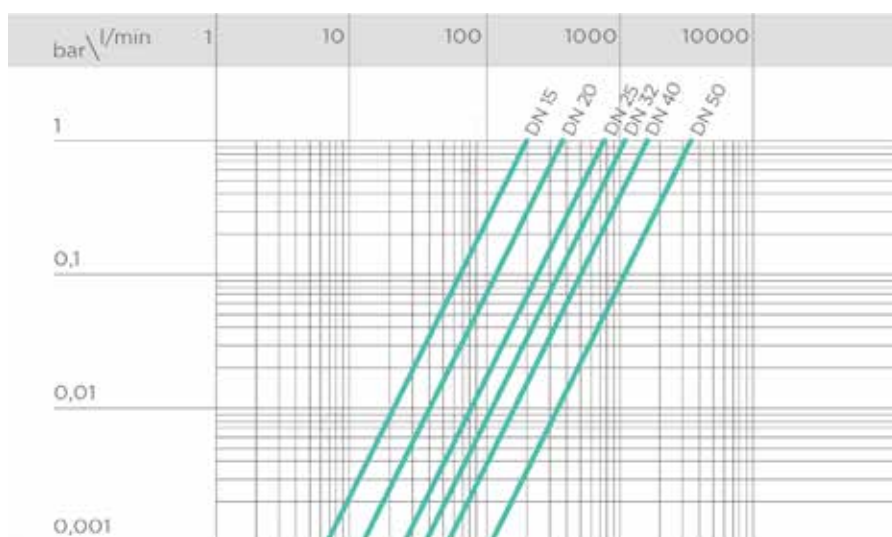

## K<sub>v</sub>100 FLOW COEFFICIENT

The K<sub>v</sub>100 flow coefficient is the Q flow rate of litres per minute of water at a temperature of 20°C that will generate Δp= 1 bar pressure drop at a certain valve position. The Kv100 values shown in the table are calculated with the valve completely open.

DN	15	20	25	32	40	50
K <sub>v</sub> 100 l/min	200	358	770	1110	1750	3400

The information in this leaflet is provided in good faith. No liability will be accepted concerning technical data that is not directly covered by recognised international standards. FIP reserves the right to carry out any modification. Products must be installed and maintained by qualified personnel.

# DIMENSIONS

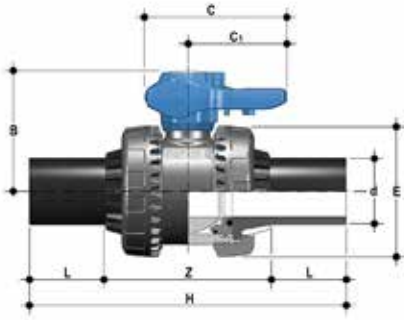

## VEEBEV

Easyfit 2-way ball valve with PE100 SDR 11 male end connectors for butt welding or electrofusion (CVDE)

d	DN	PN	B	C	C <sub>1</sub>	E	H	L	Z	g	Code
20	15	16	49	64	44	54	154	40,5	73	180	VEEBEV020E
25	20	16	62	78	55	63	189	54	81	269	VEEBEV025E
32	25	16	71	87	60	72	203	56	91	379	VEEBEV032E
40	32	16	82	102	72	85	221	56	109	591	VEEBEV040E
50	40	16	92	109	76	100	246	60,5	125	851	VEEBEV050E
63	50	16	110	133	94	118	276	65,5	145	1407	VEEBEV063E

# ACCESSORIES

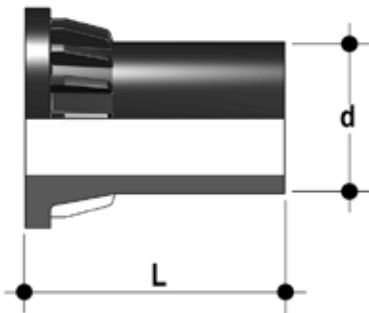

## CVDE

Long spigot PE100 end connectors for joints with electrofusion fittings or for butt welding

d	DN	PN	L	SDR	Code
20	15	16	55	11	CVDE11020
25	20	16	70	11	CVDE11025
32	25	16	74	11	CVDE11032
40	32	16	78	11	CVDE11040
50	40	16	84	11	CVDE11050
63	50	16	91	11	CVDE11063



## EASYTORQUE KIT

Kit for union nut tightening adjustment and ball seat carrier for Easyfit DN 10÷50 valves.

d	DN	Union nut tightening torque*	Seat carrier tightening torque*	Code
1/2"	15	5 N m - 3,69 Lbf ft	3 N m - 2,21 Lbf ft	KET01
3/4"	20	5 N m - 3,69 Lbf ft	3 N m - 2,21 Lbf ft	KET01
1"	25	6 N m - 4,43 Lbf ft	4 N m - 2,95 Lbf ft	KET01
1" 1/4	32	7 N m - 5,16 Lbf ft	4 N m - 2,95 Lbf ft	KET01
1" 1/2	40	8 N m - 5,90 Lbf ft	5 N m - 3,69 Lbf ft	KET01
2"	50	10 N m - 7,38 Lbf ft	6 N m - 4,43 Lbf ft	KET01

\*calculated in ideal installation conditions



## LCE

Transparent protection plug with tag holder

d	DN	VEE code
20	15	LCE020
25	20	LCE025
32	25	LCE032
40	32	LCE040
50	40	LCE050
63	50	LCE063



## LSE

Customisation and label printing set for Easyfit handle made up of pre-cut adhesive sheets and software for guided label creation.

d	DN	VEE-VXE code
20	15	LSE020
25	20	LSE025
32	25	LSE032
40	32	LSE040
50	40	LSE050
63	50	LSE063

# CUSTOMISATION

Fig. 1



Fig. 2



Fig. 3



The Easyfit VEE DN 15÷50 valve is set for the customisable Labelling System. This system lets you create special labels to insert in the handle. This makes it extremely easy to apply company logos, identification serial numbers or service indications such as, for example, the valve function in the system, the transported fluid, but also specific information for customer service, such as the customer name or installation date or location on the valves.

The grey protection plug (A) housed on the handle can be replaced with the specific LCE accessory module.

This module is made up of a rigid transparent water-resistant PVC plug (B) and white tag holder (C) made of the same material, one side of which bears the FIP logo (fig.2).

The holder, inserted in the plug, can be removed and, once overturned, used for customisation by applying labels printed with the software supplied with the LSE set.

Proceed as follows to apply the label on the valve:

- 1) Extract the handle from the valve body and extract its grey plug (fig. 1)
- 2) Apply the adhesive label on tag holder included in the LCE set to align the profiles matching the tab position.
- 3) Insert tag holder in the transparent plug so that the label is protected from the elements.
- 4) Apply the transparent plug on the handle matching the two fittings (one narrow and one wide) with their housings (fig. 3).

Fig. 4



# COMPONENTS

## EXPLODED VIEW

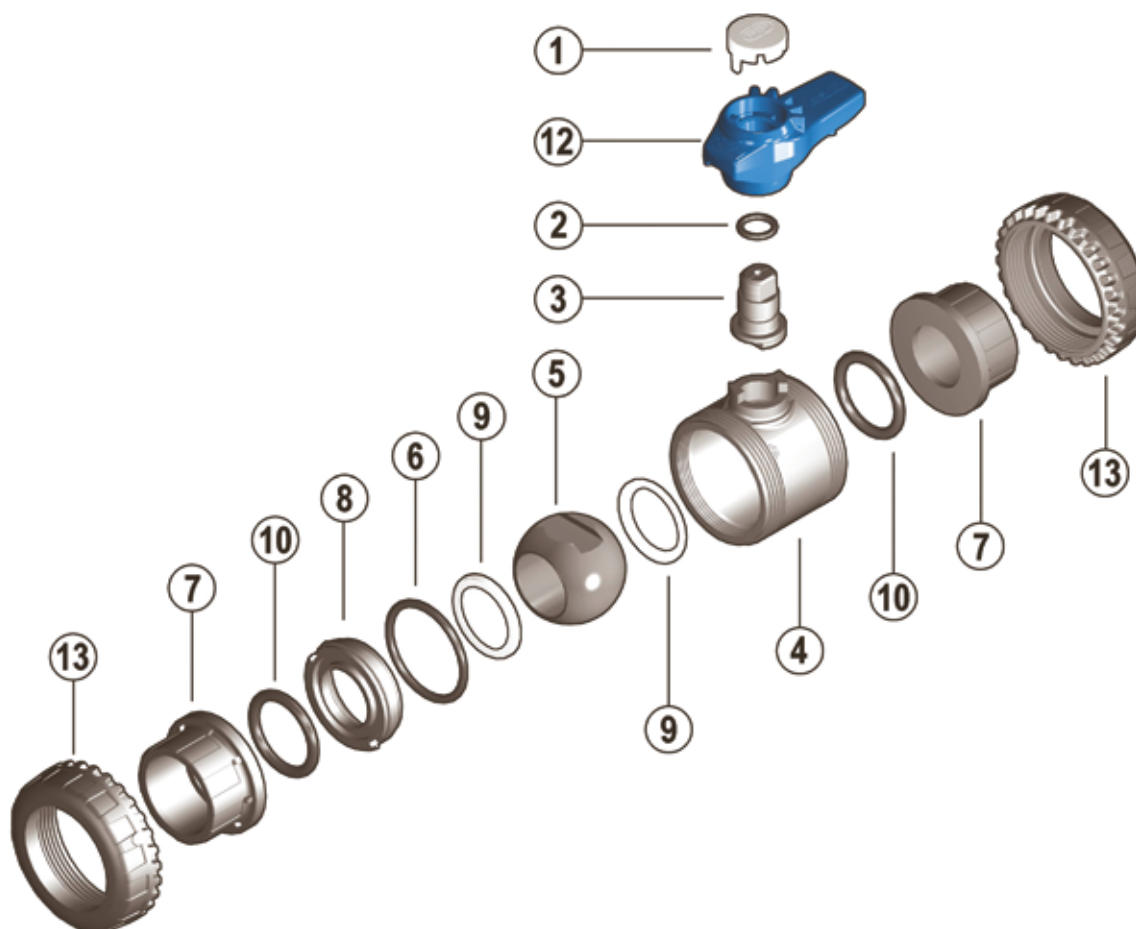

- 1 Handle plug
- 2 Stem O-rings (EPDM - 2)\*
- 3 Stem (PVC-U - 1)
- 4 Body (PVC-U - 1)

- 5 Ball (PVC-U - 1)
- 6 Radial seal O-Ring (EPDM - 1)\*
- 7 End connector (PVC-U - 2)
- 8 Ball seat carrier (PVC-U - 1)

- 9 Ball seat (PE - 2)\*
- 10 Socket seal O-Ring (EPDM-- 2)\*
- 12 Handle (HIPVC - 1)
- 13 Union nut (PVC-U - 2)

\* Spare parts  
The component material and quantity supplied are indicated in the parentheses.

## DISASSEMBLY

- 1) Isolate the valve from the line (release the pressure and empty the pipeline).
- 2) Fully unscrew the union nuts (13) from the valve body and slide the body out sideways (fig. 5-6). To do this, we recommend you use the Easyfit handle as a tool (fig. 9-10)
- 3) Before dismounting, hold the valve in a vertical position and open it 45° to drain any liquid that might remain.
- 4) After closing the valve, remove the handle (12) (fig. 7) and insert the two protrusions in the lower side in the two apertures and in the carrier passage bore (8), extracting it by turning counter-clockwise (fig. 8).
- 5) Press on the ball from the side opposite the "REGULAR" label, being sure not to scratch it, until the ball seat carrier exits (8), then extract the ball (5).
- 6) Press the stem (3) inwards until it exits the body.
- 7) Remove the O-Rings (2, 6, 10) and ball seats (9) extracting them from their seats, as illustrated in the exploded view.

## ASSEMBLY

- 1) All the O-Rings (2, 6, 10) must be inserted in their grooves as shown in the exploded view.
- 2) Insert the stem (3) from inside the body (4).
- 3) Place the ball seats (9) in the housings in the body (4) and in the carrier (8).
- 4) Insert the ball (5) rotating it to the closed position.
- 5) Screw the carrier (8) into the body and tighten up in the clockwise direction using the handle (12) to limit stop.
- 6) Position the valve between the end connectors (7) and tighten the union nuts (13) clockwise using the Easyfit multifunctional handle, being sure the socket seal O-Rings (10) do not exit the seats.
- 7) Position the handle (12) on the stem (3).



**Note:** during assembly operations, it is advisable to lubricate the rubber seals. Mineral oils are not recommended for this task as they react aggressively with EPDM rubber.

Fig. 5



Fig. 6



Fig. 7



Fig. 8





# INSTALLATION

Before proceeding with installation, please follow these instructions carefully:

- 1) Check that the pipes to be connected to the valve are aligned in order to avoid mechanical stress on the threaded joints.
- 2) Unscrew the union nuts (13) and slide them onto the pipe.
- 3) Solvent weld or screw the end connectors (7) onto the pipe segments.
- 4) Position the valve between the end connectors (fig. 6). Warning: if a high pressure test is required, always position the body with the "REGULAR" label upstream from the fluid direction.
- 5) Fit the union nuts on the valve body and manually tighten clockwise until they become hard to turn; do not use wrenches or other tools that can damage the union nut surfaces.
- 6) Extract the handle (12) from the valve body and extract its grey plug (1) (fig. 2)
- 7) Overturn the handle and insert it on the valve stem matching the handle teeth (A) with the union nut teeth (B) (fig. 9-10).
- 8) Turn the handle counter-clockwise to fully tighten the union nut. The rotation directions to tighten (TIGHTEN) and loosen (UNTIGHTEN) the union nuts are indicated on the handle (fig. 11). Generally, if pipes are not offset, one turn is sufficient for correct tightening.
- 9) Repeat point 7 for the other union nut. Note: A small force applied on the handle develops a torque much higher than manual tightening. You can also, using the Easytorque kit (fig. 12), supplied as an accessory, tighten union nuts using a torque wrench to quantify the force and thus monitor the stress applied to the thermoplastic threads according to the installation indications in the instructions enclosed with the kit.
- 10) Apply the plug (1) on the handle (12) matching the two fittings (one narrow and one wide) with the relevant housings on the handle (fig. 3).
- 11) Install the handle (12) on the stem (3) again.
- 12) If necessary, support the pipe with FIP pipe clip model ZIKM and DSM distance plates.

## WARNINGS

If volatile liquid such as Hydrogen Peroxide (H<sub>2</sub>O<sub>2</sub>) or Sodium Hypochlorite (NaClO) is used, for safety reasons we recommend you contact the service centre. These liquids, upon vaporising, could create hazardous over pressures in the area between the body and ball.

Do not use compressed air or other gases to test thermoplastic lines.

Always avoid sudden closing manoeuvres and protect the valve from accidental manoeuvres.

Fig. 9



Fig. 10



Fig. 11



Fig. 12







# VEE DN 65÷100

FIP and Giugiaro Design designed and developed VEE Easyfit, the innovative True Union ball valve that permits simple and safe installation for reliable service over time.

The valve is specifically designed for water conveyance applications.



## EASYFIT 2-WAY BALL VALVE

- **Patented Easyfit system:** innovative mechanism that lets you use the quick release handle to adjust the ball carrier
- Connection system for solvent weld and threaded joints
- **Valve material compatibility** (PVC-U) with water, drinking ware and other food substances according to **current regulations**
- Easy radial dismounting allowing quick replacement of O-rings and ball seats without any need for tools
- **PN16 True Union valve body** made for PVC-U injection moulding and European Directive 2014/68/EU (PED) compliant for pressurised equipment. ISO 9393 compliant test requirements
- Valve body with built-in anchoring frame for the special **Power Quick Easyfit module** dedicated to the installation of pneumatic and electric actuators or accessories
- Option of dismounting downstream pipes with the valve in the closed position
- Floating **full bore ball** with high surface finish made in CNC work stations to achieve precise dimensional tolerance and high surface finish

### Technical specifications

<b>Construction</b>	Easyfit 2-way True Union ball valve with locked carrier
<b>Size range</b>	DN 65 ÷ 100
<b>Nominal pressure</b>	PN 16 with water at 20 °C
<b>Temperature range</b>	0 °C ÷ 60 °C
<b>Reference standards</b>	<b>Construction criteria:</b> EN ISO 16135, EN ISO 1452, EN ISO 15493 <b>Test methods and requirements:</b> ISO 9393 <b>Installation criteria:</b> DVS 2204, DVS 2221, UNI 11242 <b>Actuator couplings:</b> ISO 5211
<b>Valve material</b>	PVC-U
<b>Seal material</b>	EPDM (standard size O-Ring); PE (ball seats)
<b>Control options</b>	Manual control

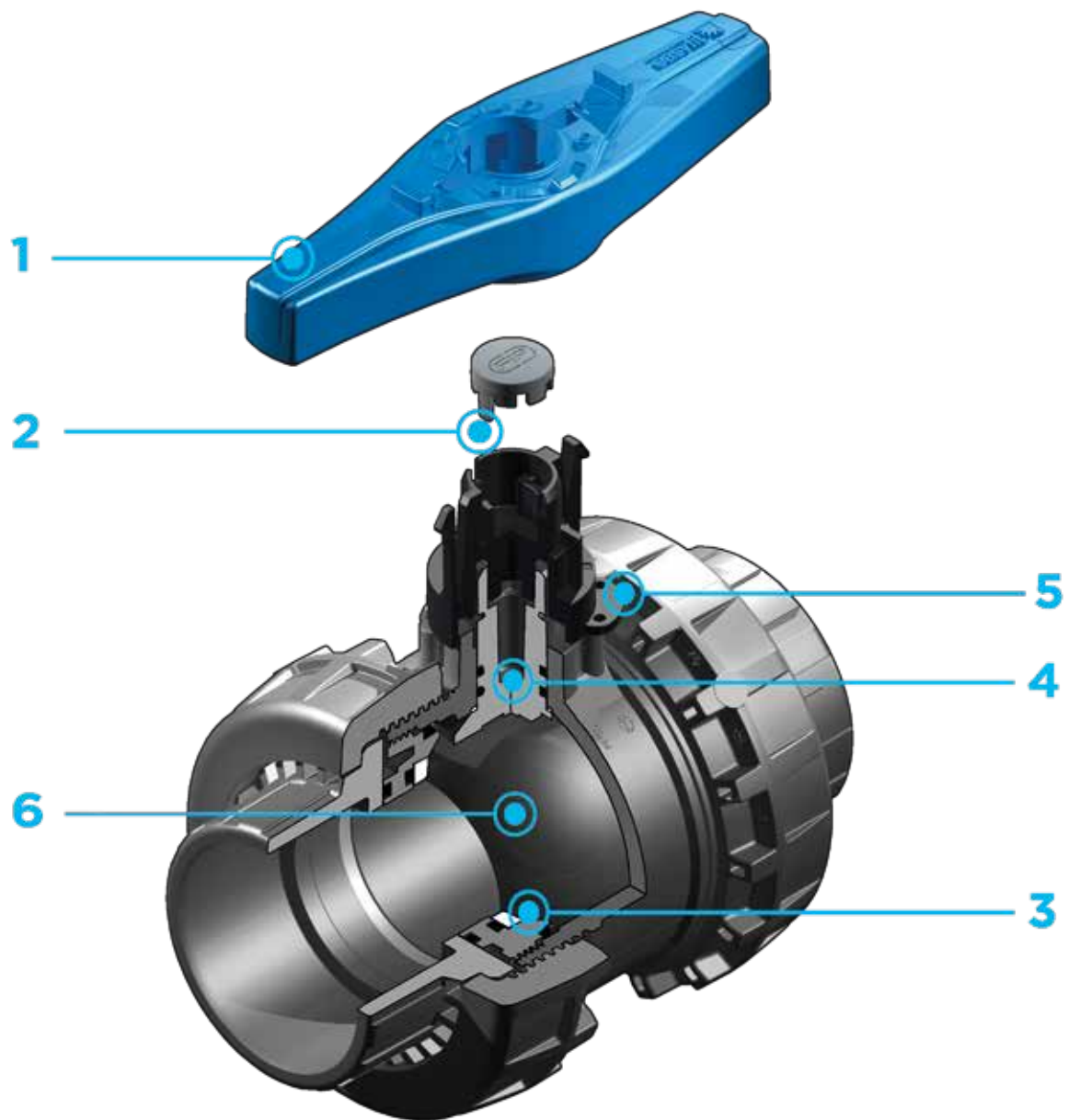

**1 Innovative quick release Easyfit handle** made up of a central hub firmly coupled with the stem by a **dual spoke grip** that can be released from the hub with a simple operation and used as a **ball seat adjustment tool**

**2** Settings for the customisable Labelling System using the LCE module (available as an accessory). The grey protection plug housed on the central hub can be replaced with the

transparent plug and customisable tag holder with the LSE set (available as an accessory). The **customisation lets you identify the valve on the system** according to specific needs

**3 PE seal system with locked carrier** adjustable via the Easyfit quick release handle

**4 Stem** with high surface finish and **double O-Ring and PTFE anti-**

**friction disk** that limits friction to a minimum and grants excellent operating torque

**5** Valve body set for SHE kit installation (available as an accessory) that blocks the closing and opening manoeuvres with a lock

**6** Machined high surface finish ball that guarantees a smooth operation and increased reliability

# TECHNICAL DATA

## PRESSURE VARIATION ACCORDING TO TEMPERATURE

For water and harmless fluids to which the material is classified as CHEMICALLY RESISTANT. In other cases, a reduction of the nominal PN pressure is required (25 years with safety factor).



## PRESSURE DROP GRAPH

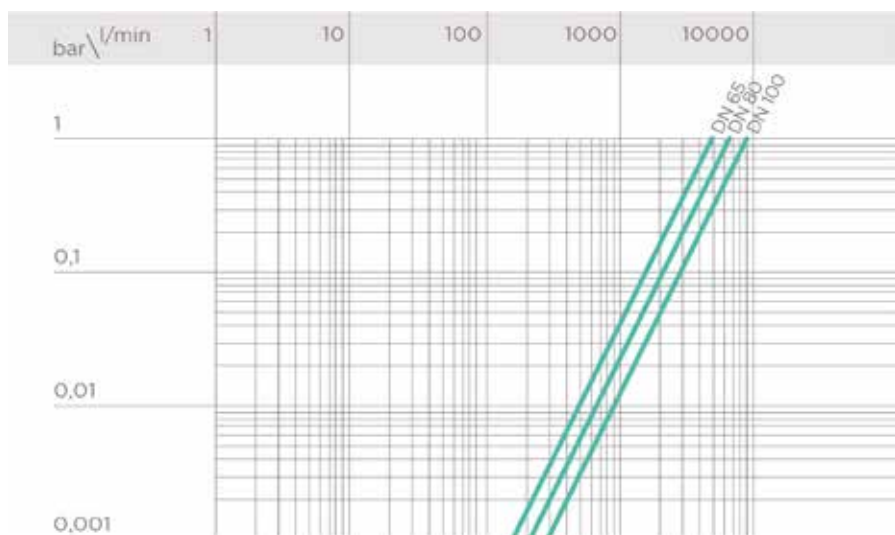

## K<sub>v</sub>100 FLOW COEFFICIENT

The K<sub>v</sub>100 flow coefficient is the Q flow rate of litres per minute of water at a temperature of 20°C that will generate Δp= 1 bar pressure drop at a certain valve position. The K<sub>v</sub>100 values shown in the table are calculated with the valve completely open.

DN	65	80	100
K <sub>v</sub> 100 l/min	5000	7000	9400

## OPERATING TORQUE AT MAXIMUM WORKING PRESSURE

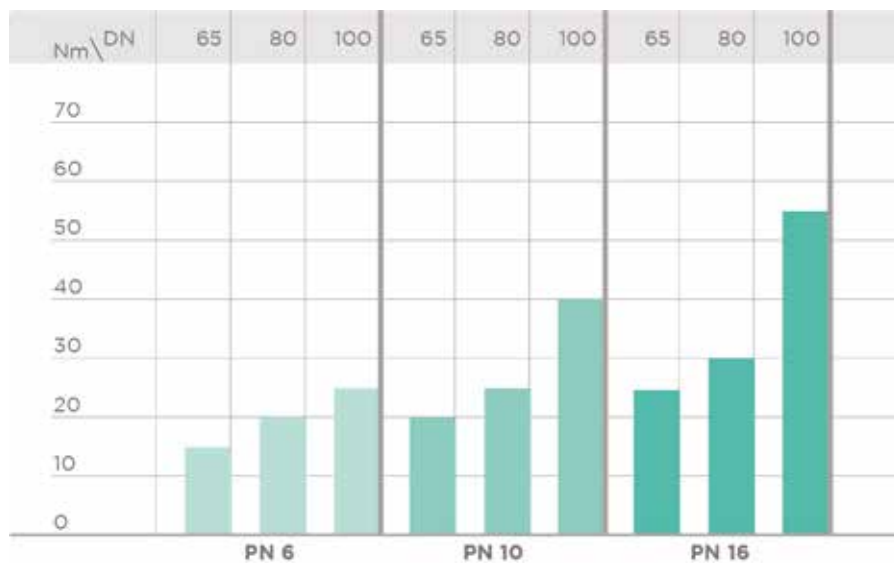

The information in this leaflet is provided in good faith. No liability will be accepted concerning technical data that is not directly covered by recognised international standards. FIP reserves the right to carry out any modification. Products must be installed and maintained by qualified personnel.

# DIMENSIONS



## VEEBEV

Easyfit 2-way ball valve with PE100 SDR 11 male end connectors for butt welding or electrofusion (CVDE)

d	DN	PN	B	C	C <sub>1</sub>	E	H	L	Z	g	Code
75	65	16	141,5	214	115	157	331	71	189	2286	VEEBEV075E
90	80	10	151	239	126	174	367	88	191	3059	VEEBEV090E
110	100	10	174,5	270	145	212	407	92	223	5814	VEEBEV110E

# ACCESSORIES

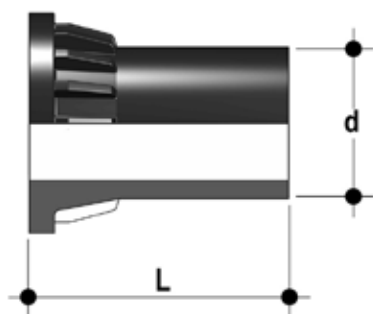

## CVDE

Long spigot PE100 end connectors for joints with electrofusion fittings or for butt welding

d	DN	PN	L	SDR	Code
75	65	16	111	11	CVDE11075
90	80	16	118	11	CVDE11090VXE
110	100	16	127	11	CVDE11110VXE

## PSE

Stem extension

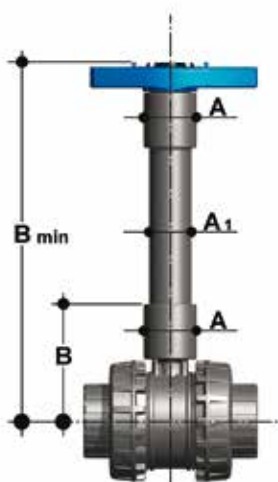

d	inch	DN	A	A <sub>1</sub>	B	B min	ISO pipe code	ASTM-BS pipe code
75	2 1/2	65	76	63	159	364	PSE090	PSE300
90	3"	80	76	63	166	371	PSE090	PSE300
110	4"	100	76	63	186	433	PSE110	PSE400

## LCE

Transparent protection plug with tag holder



d	DN	VEE code
75	65	LCE040
90	80	LCE040
110	100	LCE040



## LSE

Customisation and label printing set for Easyfit handle made up of pre-cut adhesive sheets and software for guided label creation.

d	DN	VXE - VEE code
75	65	LSE040
90	80	LSE040
110	100	LSE040



## SHE

Anti-tampering lock kit

d	DN	to be used with:	Code
75	65	VEE - VXE	SHE090
90	80	VEE - VXE	SHE090
110	100	VEE - VXE	SHE110



# CUSTOMISATION

Fig. 1



Fig. 2

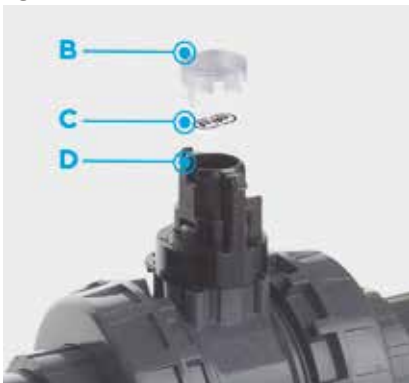

Fig. 3



The Easyfit VEE DN 65÷100 valve is set for the customisable Labelling System. This system lets you create special labels to insert in the handle. This makes it extremely easy to apply company logos, identification serial numbers or service indications such as, for example, the valve function in the system, the transported fluid, but also specific information for customer service, such as the customer name or installation date or location on the valves.

The grey protection plug (A) housed on the handle can be replaced with the specific LCE accessory module.

This module is made up of a rigid transparent water-resistant PVC plug (B) and white tag holder (C) made of the same material, one side of which bears the FIP logo (fig. 2).

The holder, inserted in the plug, can be removed and, once overturned, used for customisation by applying labels printed with the software supplied with the LSE set.

Proceed as follows to apply the label on the valve:

- 1) Release the handle from the central hub (D) and extract the grey plug (fig. 1).
- 2) Apply the adhesive label on tag holder included in the LCE set to align the profiles matching the tab position.
- 3) Insert tag holder in the transparent plug so that the label is protected from the elements (fig. 3).
- 4) Apply the transparent plug on the central hub matching the two fittings (one narrow and one wide) with the relevant housings.

Fig. 4



# COMPONENTS

## EXPLODED VIEW

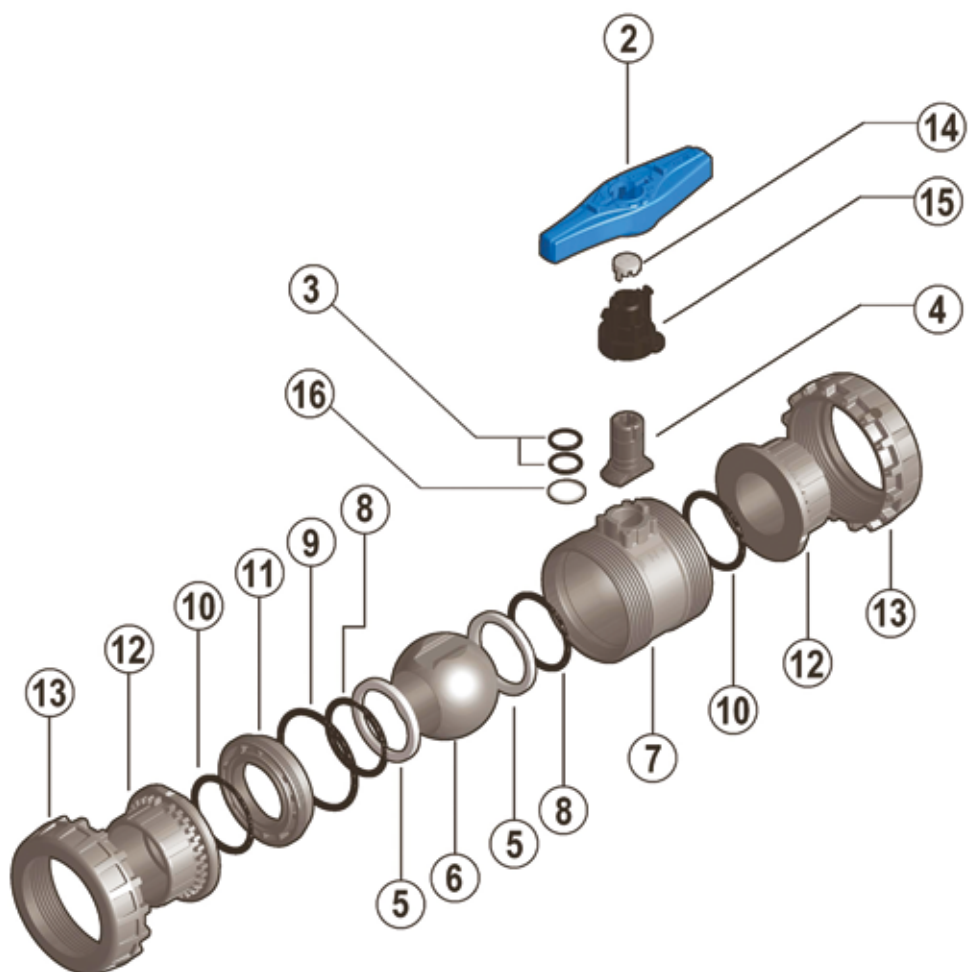

**2** Easyfit quick release handle (HIPVC - 1)

**3** Stem O-rings (EPDM\*\* - 2)\*

**4** Stem (PVC-U - 1)

**5** Ball seat (PE - 2)\*

**6** Ball (PVC-U - 1)\*

**7** Body (PVC-U - 1)

**8** Ball seat O-Ring (EPDM - 2)\*

**9** Radial seal O-Ring (EPDM - 1)\*

**10** Socket seal O-Ring (EPDM - 2)\*

**11** Ball seat carrier (PVC-U - 1)

**12** End connector (PVC-U - 2)

**13** Union nut (PVC-U - 2)

**14** Grey protection plug (PVC - 1)

**15** Central hub (HIPVC - 1)

**16** Anti-friction disk (PTFE - 1)\*

\* Spare parts

The component material and quantity supplied are indicated in the parentheses.

## DISASSEMBLY

- 1) Isolate the valve from the line (release the pressure and empty the pipeline).
- 2) Fully unscrew the union nuts (13) from the valve body and slide the body out sideways (7) (fig. 7-8).
- 3) Before dismounting, hold the valve in a vertical position and open it 45° to drain any liquid that might remain.
- 4) Open the valve.
- 5) Remove the ball seat carrier (11) using the Easyfit quick release handle (2). Extract the handle from the central hub (15) pushing towards the hub hinge centres (fig. 5-6). Insert the two protrusion at the top of the handle in the carrier seats (11) and unscrew, extracting it by turning counter-clockwise (fig. 9-10).
- 6) Press on the ball (6) from the side opposite the "REGULAR" label, being sure not to scratch it, until the ball seat exits (11) then extract the ball (6).
- 7) Remove the central hub (15) firmly sliding it off the stem (4). Press the stem inwards and extract it from the body and remove the anti-friction disk (16).
- 8) Remove the O-Ring (3, 8, 9, 10) and ball seats (5) extracting them from their seats, as illustrated in the exploded view.

## ASSEMBLY

- 1) All the O-rings (3, 8, 9, 10) must be inserted in their grooves as shown in the exploded view.
- 2) Place the anti-friction disk (16) on the stem (4) and insert it in the body (7).
- 3) Place the ball seats (5) in the housings in the body (7) and in the carrier (11).
- 4) Insert the ball (6) rotating it to the closed position.
- 5) Screw the carrier (11) into the body and tighten up in the clockwise direction using the handle (2) to limit stop.
- 6) Place the central hub (15) on the stem (4) firmly pressing down to match the internal hub key with one of the two seats on the stem.
- 7) Position the valve between the end connectors (12) and tighten the union nuts (13) clockwise making sure the socket seal O-Rings (10) do not exit the seats (fig. 7-8).
- 8) Reposition the handle (2) on the central hub (15) making sure the two grooves in the central handle bore match the two grooves on the side of the hub and slightly press down until the two hinges click.



**Note:** during assembly operations, it is advisable to lubricate the rubber seals. Mineral oils are not recommended for this task as they react aggressively with EPDM rubber.

Fig. 5



Fig. 6



Fig. 7



Fig. 8



# INSTALLATION

Before proceeding with installation, please follow these instructions carefully:

- 1) Check that the pipes to be connected to the valve are aligned in order to avoid mechanical stress on the threaded joints.
- 2) Unscrew the union nuts (13) from the body (7) and insert them in the pipe segments.
- 3) Solvent weld or screw the end connectors (12) onto the pipe segments.
- 4) Position the valve between the end connectors (fig. 8). Warning: if a high pressure test is required, always position the body with the "REGULAR" label upstream from the fluid direction.
- 5) Fit the union nuts on the valve body and tighten clockwise (fig. 7).
- 6) If necessary, support the pipe with FIP pipe clip model ZIKM and DSM distance plates.

The VEE valve can be equipped with a simple locking device by inserting a lock to protect the system against tampering (fig. 12). The valve body and hub are, in fact, set to house a lockable plate on the valve body using two self-threading screws (see SHE accessories) (fig. 11),

## WARNINGS

If volatile liquid such as Hydrogen Peroxide (H<sub>2</sub>O<sub>2</sub>) or Sodium Hypochlorite (NaClO) are used, for safety reasons we recommend you contact the service centre. These liquids, upon vaporising, could create hazardous over pressures in the area between the body and ball.

Always avoid sudden closing manoeuvres and protect the valve from accidental manoeuvres.

Fig. 9



Fig. 10



Fig. 11



Fig. 12





# SXE-SSE DN 15÷50

The Easyfit check valve line developed with Giugiaro Design offers two different versions: SXE with ball shutter and SSE with spring loaded shutter. Easyfit check valves stand out for the innovative installation method that guarantees reliable service over time. This valve is also equipped with the customisable Labelling System.



## EASYFIT TRUE UNION BALL AND SPRING CHECK VALVE

- **Valve material compatibility (PVC-U)** with water conveyance, drinking water and other food substances according to current regulations
- **PN16 True Union** valve body made for PVC-U injection moulding and European Directive 2014/68/EU (PED) compliant for pressurised equipment. ISO 9393 compliant test requirements
- **Short face to face dimension** according to international regulation ISO 7508 series III and European regulation EN 1452 "short" and fully interchangeable with VXE and VEE DN 15÷50 ball valve models
- Union nuts with rack for tightening adjustment via Easyfit handle or via Easy-torque adjustment kit (available as accessories)
- **Vertical** (preferable for SXE model) and **horizontal installation** potential

### Technical specifications

<b>Construction</b>	<b>SXE:</b> Easyfit True Union ball check valve with locked carrier. <b>SSE:</b> Easyfit True Union spring check valve
<b>Size range</b>	DN 15 ÷ 50
<b>Nominal pressure</b>	PN 16 with water at 20 °C
<b>Temperature range</b>	0 °C ÷ 60 °C
<b>Reference standards</b>	<b>Criteri Costruttivi:</b> EN ISO 16137, EN ISO 1452, EN ISO 15493 <b>Metodi e requisiti dei test:</b> ISO 9393 <b>Installation criteria:</b> DVS 2204, DVS 2221, UNI 11242
<b>Valve material</b>	PVC-U
<b>Seal material</b>	EPDM (standard size O-Ring)
<b>Spring material (SSE)</b>	Available in STAINLESS steel 316, Hastelloy C276, A316 PTFE encapsulated (DN 32, DN 40 and DN 50 only)

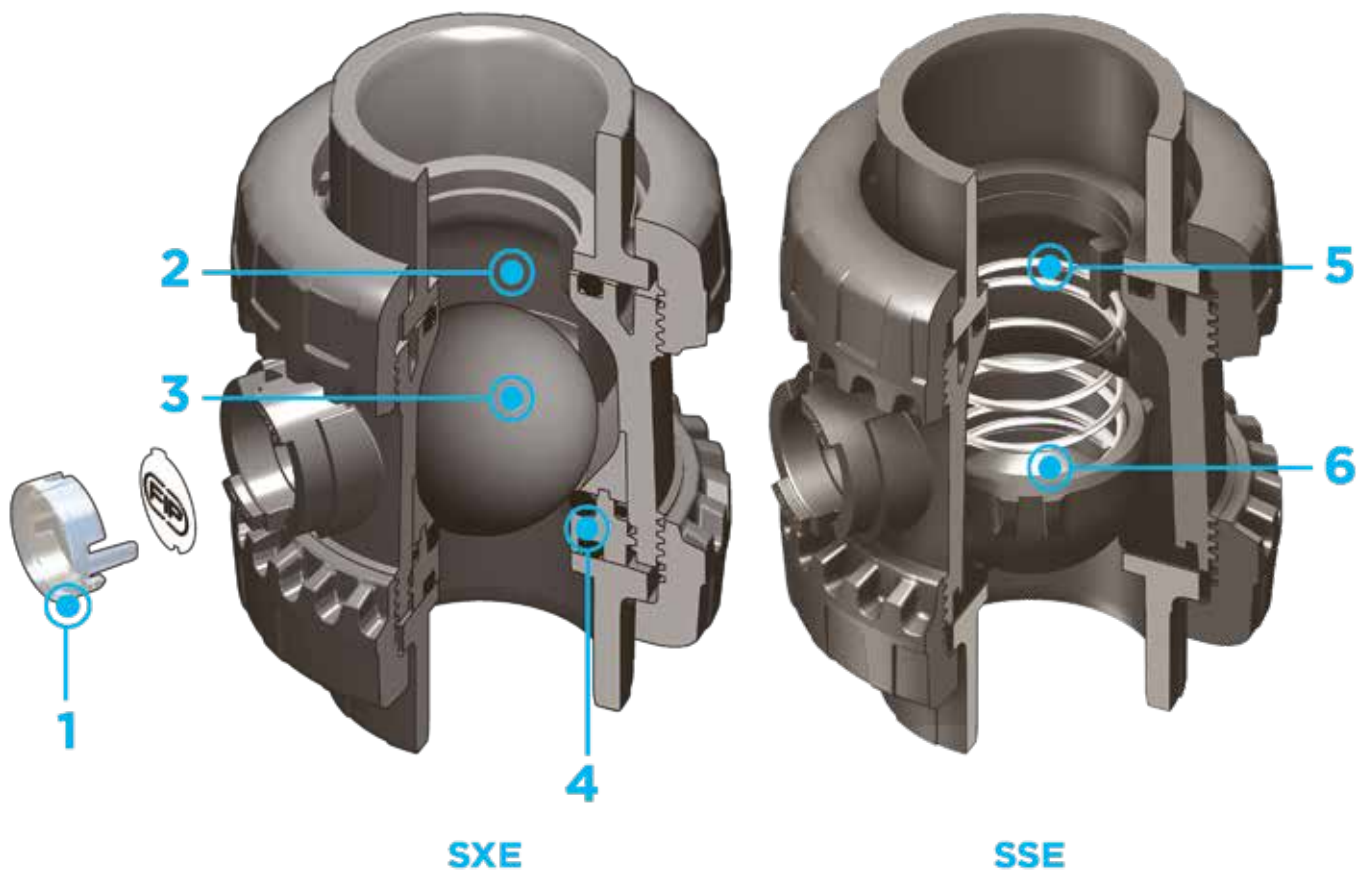

- 1 Customisable Labelling System:** built-in LCE module on the valve body made up of transparent protection plug and customisable tag holder using the LSE set (available as accessory). The customisation potential lets you identify the valve on the system according to specific needs.
- 2 Optimised dynamic fluid design:** energy savings thanks to the improved valve Kv value with consequent pressure drop reduction
- 3 High surface finish ball shutter:** wear reduction, increase in working life and reduced valve maintenance. Ideal for conveying dirty fluids, even with suspended solids and filaments thanks to the special design that permits **internal valve selfcleaning**
- 4 Locked ball seat carrier:** safe dismantling for maintenance with the Easyfit multifunctional handle or Easytorque kit
- 5 Ideal for horizontal installations:** perfect seal even with low back pressure. Silent and durable even with strong vibrations and pulsating fluid
- 6 PVC-U shutter and springs available made of STAINLESS steel 316, Hastelloy C276, A316 PTFE encapsulated:** maximum reliability in a **wide field of applications** from salt water to aggressive acids



# TECHNICAL DATA

## PRESSURE VARIATION ACCORDING TO TEMPERATURE

For water and harmless fluids to which the material is classified as CHEMICALLY RESISTANT. In other cases, a reduction of the nominal PN pressure is required (25 years with safety factor).



## PRESSURE DROP GRAPH



## K<sub>v</sub>100 FLOW COEFFICIENT

The K<sub>v</sub>100 flow coefficient is the Q flow rate of litres per minute of water at a temperature of 20°C that will generate Δp= 1 bar pressure drop at a certain valve position. The Kv100 values shown in the table are calculated with the valve completely open.

DN	15	20	25	32	40	50
Kv100 l/min	152	258	433	643	928	1343

## MINIMUM VALVE SEALING PRESSURE

The PVC-U SXE valve can only be used with liquids with specific weight under 1.37g/cm<sup>3</sup>.

DN	15	20	25	32	40	50
SXE (bar)	0,2	0,2	0,2	0,2	0,2	0,2
SSE (bar)	0,08	0,08	0,08	0,08	0,08	0,08

The information in this leaflet is provided in good faith. No liability will be accepted concerning technical data that is not directly covered by recognised international standards. FIP reserves the right to carry out any modification. Products must be installed and maintained by qualified personnel.



# DIMENSIONS



## SXEBEV

Easyfit ball check valve with PE100 SDR 11 male ends for butt welding or electrofusion welding (CVDE)

d	DN	E	H	L	Z	g	EPDM code
20	15	54	154	40,5	73	150	SXEBEV020E
25	20	63	189	54	81	225	SXEBEV025E
32	25	72	203	56	91	310	SXEBEV032E
40	32	85	221	56	109	485	SXEBEV040E
50	40	100	246	60,5	125	700	SXEBEV050E
63	50	118	276	65,5	145	1150	SXEBEV063E



## SSEBEV

Easyfit spring check valve with PE100 SDR 11 male end connectors for butt welding or electrofusion (CVDE)

d	DN	E	H	L	Z	g	EPDM code
20	15	54	154	40,5	73	151	SSEBEV020E
25	20	63	186	54	81	223	SSEBEV025E
32	25	72	199	56	91	302	SSEBEV032E
40	32	85	217	56	109	470	SSEBEV040E
50	40	100	236	60,5	125	665	SSEBEV050E
63	50	118	268	65,5	145	1080	SSEBEV063E

# ACCESSORIES

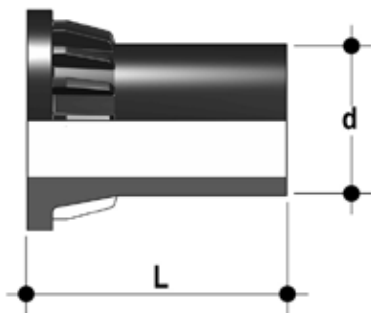

## CVDE

Long spigot PE100 end connectors for joints with electrofusion fittings or for butt welding

d	DN	PN	L	SDR	Code
20	15	16	55	11	CVDE11020
25	20	16	70	11	CVDE11025
32	25	16	74	11	CVDE11032
40	32	16	78	11	CVDE11040
50	40	16	84	11	CVDE11050
63	50	16	91	11	CVDE11063

## Easyfit handle

Easyfit multifunctional handle for union nut tightening SXE-SSE DN 10÷50



d	DN	Code
20	15	HAVXE020
25	20	HAVXE025
32	25	HAVXE032
40	32	HAVXE040
52	40	HAVXE050
63	50	HAVXE063

## EASYTORQUE KIT

Kit for union nut tightening adjustment and ball seat carrier for Easyfit DN 10÷50 valves.



d	DN	Union nut tightening torque*	Seat carrier tightening torque*	Code
1/2"	15	5 N m - 3,69 Lbf ft	3 N m - 2,21 Lbf ft	KET01
3/4"	20	5 N m - 3,69 Lbf ft	3 N m - 2,21 Lbf ft	KET01
1"	25	6 N m - 4,43 Lbf ft	4 N m - 2,95 Lbf ft	KET01
1" 1/4	32	7 N m - 5,16 Lbf ft	4 N m - 2,95 Lbf ft	KET01
1" 1/2	40	8 N m - 5,90 Lbf ft	5 N m - 3,69 Lbf ft	KET01
2"	50	10 N m - 7,38 Lbf ft	6 N m - 4,43 Lbf ft	KET01

\*calculated in ideal installation conditions

## LSE

Customisation and label printing set for Easyfit handle made up of precut adhesive sheets and software for guided label creation.



d	DN	SXE-SSE code
20	15	-
25	20	-
32	25	LSE020
40	32	LSE025
50	40	LSE032
63	50	LSE032

# CUSTOMISATION

Fig. 1



Fig. 2



Fig. 3



SXE and SSE DN 15÷50 Easyfit valves are equipped with a customisable Labelling System.

This system lets you create special labels to affix to the valve body. This makes it extremely easy to apply company logos, identification serial numbers or service indications such as, for example, the valve function in the system, the transported fluid, but also specific information for customer service, such as the customer name or installation date or location on the valves.

The specific LCE module is a standard supply and is made up of a rigid transparent water-resistant PVC plug and white tag holder made of the same material, one side of which bears the FIP logo (fig. 1).

The holder, inserted in the plug, can be removed and, once overturned, used for customisation by applying labels printed with the software supplied with the LSE set.

Proceed as follows to apply the label on the valve:

- 1) Extract the transparent plug from the seat on the valve body (fig. 1).
- 2) Extract the tag holder from the transparent plug (fig. 2).
- 3) Apply the adhesive label on the tag holder to align the profiles matching the tab position.
- 4) Re-insert the tag holder in the transparent plug so that the label is protected from the elements.
- 5) Replace the transparent plug in its seat on the valve body.

# COMPONENTS

## EXPLODED VIEW



**SSE**

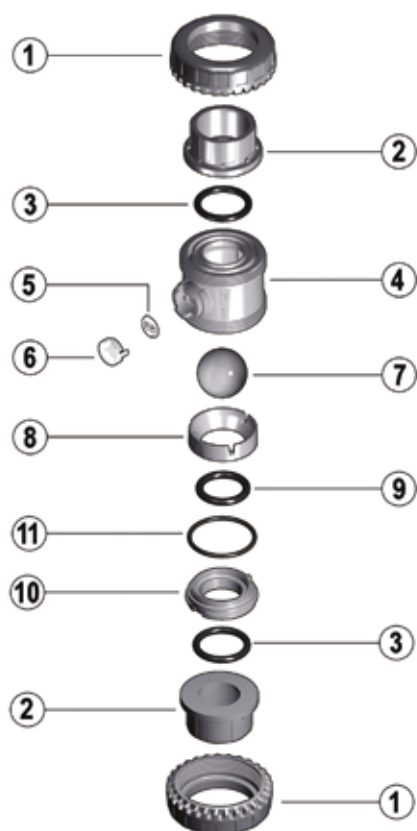

**SXE**

- |          |                                    |            |                                       |            |                                   |
|----------|------------------------------------|------------|---------------------------------------|------------|-----------------------------------|
| <b>1</b> | Union nut (PVC-U - 2)              | <b>6</b>   | Transparent protection plug (PVC - 1) | <b>9</b>   | Ball seat O-Ring (EPDM, FKM - 1)  |
| <b>2</b> | End connector (PVC-U - 2)          | <b>7</b>   | Ball (PVC-U - 1)                      | <b>SXE</b> |                                   |
| <b>3</b> | Socket seal O-Ring (EPDM, FKM - 2) | <b>SXE</b> |                                       | <b>9</b>   | Shutter gasket (EPDM, FKM - 1)    |
| <b>4</b> | Body (PVC-U - 1)                   | <b>7</b>   | Shutter (PVC-U - 1)                   | <b>SSE</b> |                                   |
| <b>5</b> | Tag holder (PVC - 1)               | <b>SSE</b> |                                       | <b>10</b>  | Ball seat carrier (PVC-U - 1)     |
|          |                                    | <b>8</b>   | Gland packing ring (PVC-U - 1)        | <b>11</b>  | Radial seal O-Ring (EPDM,FKM - 1) |
|          |                                    |            |                                       | <b>12</b>  | Spring (STAINLESS steel* - 1)     |

\* Also available made of Hastelloy C276 or A316 PTFE encapsulated (for DN 40 and DN 50 only)  
The component material and quantity supplied are indicated in the parentheses.

## DISASSEMBLY

### SXE

SXE valves do not require maintenance in normal operating conditions. In the event of leaks or wear, before performing maintenance, cut-off fluid upstream from the valve and make sure it is de-pressurised (downstream drain if necessary).

- 1) Fully drain residual liquid that could be aggressive for the operator and, if possible, circulate water to internally clean the valve.
- 2) To easily unscrew the union nuts when dismantling, use the Easyfit multifunctional handle (supplied as an accessory) (fig. 4) or Easytorque kit (fig. 5-6).
- 3) Unscrew the seal carrier (10) with the Easyfit multifunctional handle (fig. 7) or Easytorque kit (fig. 8).
- 4) Remove all internal components.

### SSE

In the event of leaks or wear, before performing maintenance, cut-off fluid upstream from the valve and make sure it is de-pressurised (downstream drain if necessary).

- 1) Fully drain residual liquid that could be aggressive for the operator and, if possible, circulate water to internally clean the valve.
- 2) To easily unscrew the union nuts when dismantling, use the Easyfit multifunctional handle (supplied as an accessory) (fig. 4) or Easytorque kit (fig. 5-6).
- 3) Extract the ball seat O-ring (9).
- 4) Remove all internal components.

## ASSEMBLY

### SXE

- 1) Reconstruct the valve following the exploded view on the previous page
- 2) Tighten the ball seat carrier (10) using the Easyfit multifunctional handle (fig. 7) or Easytorque wrench (fig. 8) according to the torque indicated in the enclosed instructions. This way valve installation and excellent operations are guaranteed
- 3) Position the valve between the end connectors (2) and tighten the union nuts clockwise (1) using the Easyfit multifunctional handle (fig. 4) or Easytorque kit (fig. 5-6), being sure the socket seal O-ring (3) does not exit the seats.

### SSE

- 1) Reconstruct the valve following the exploded view on the previous page.
- 2) Position the valve between the end connectors (2) and tighten the union nuts clockwise (1) using the Easyfit multifunctional handle (fig. 4) or Easytorque kit (fig. 5-6), being sure the socket seal O-ring (3) does not exit the seats.



**Note:** during assembly operations, it is advisable to lubricate the rubber seals. Mineral oils are not recommended for this task as they react aggressively with EPDM rubber.

Fig. 4



Fig. 5



Fig. 6



Fig. 7



# INSTALLATION

SXE-SSE valves can be installed both vertically (upward flow) or horizontally (SXE with a minimum 0.2 bar back pressure). Before proceeding with installation, please follow these instructions carefully:

- 1) Check that the pipes to be connected to the valve are aligned in order to avoid mechanical stress on the threaded joints.
- 2) Unscrew the union nuts (1) from the body (4) and insert them in the pipe segments.
- 3) Solvent weld or screw the end connectors (2) onto the pipe segments.
- 4) Position the valve body between the end connectors (fig. 9).
- 5) Fit the union nuts on the valve body and manually tighten clockwise until they become hard to turn; do not use wrenches or other tools that can damage the union nut surfaces.
- 6) For easy union nut tightening in assembly, use the Easyfit multifunctional handle (supplied as an accessory).
- 7) Overturn the handle and insert it on the stem so the handle teeth (A) match the union nut teeth (B) (fig. 10)
- 8) Turn the handle counter-clockwise to fully tighten the union nut (fig. 10). The rotation directions to tighten (TIGHTEN) and loosen (UNTIGHTEN) the union nuts are indicated on the handle (fig. 11). Generally, if pipes are not offset, a single turn is sufficient for correct tightening.
- 9) Repeat point 7 for the other union nut. Note: A small force applied on the handle develops a torque much higher than manual tightening. You can also, using the Easytorque kit (fig. 5-6), supplied as an accessory, tighten union nuts using a torque wrench to quantify the force and thus monitor the stress applied to the thermoplastic threads according to the installation indications in the instructions enclosed with the kit.
- 10) If necessary, support pipes with FIP pipe clip model ZIKM and DSM distance plates.

## WARNINGS

Do not use compressed air or other gases to test thermoplastic lines.  
Always avoid sudden closing manoeuvres and protect the valve against accidental manoeuvres.  
Leave a straight section of pipe of length equal to 5 times the nominal diameter before and after the valve.

Fig. 8



Fig. 9



Fig. 10



Fig. 11





# SXE-SSE DN 65÷100

The Easyfit check valve line developed with Giugiaro Design offers two different versions: SXE with ball shutter and SSE with spring loaded shutter. Easyfit check valves stand out for the innovative installation method that guarantees reliable service over time. This valve is also equipped with a customisable Labelling System.



## EASYFIT TRUE UNION BALL AND SPRING CHECK VALVE

- Connection system for solvent weld and threaded joints
- **Valve material compatibility** (PVC-U) with water, drinking water and other food substance conveyance according to **current regulations**
- **PN16 True Union valve body** made for PVC-U injection moulding and European Directive 2014/68/EU (PED) compliant for pressurised equipment. ISO 9393 compliant test requirements
- Easy radial dismounting and fully interchangeable with VEE and VXE 65-100 valve models
- Union nut profile that perfectly adapts to the Easyfit multifunctional handle hooked insert (available as an accessory) that lets you control union nut rotation
- **Vertical** (preferable for SXE model) and **horizontal installation** potential

### Technical specifications

<b>Construction</b>	<b>SXE:</b> Easyfit True Union ball check valve with locked carrier <b>SSE:</b> Easyfit True Union spring check valve with locked carrier
<b>Size range</b>	DN 65 ÷ 100
<b>Nominal pressure</b>	PN 16 with water at 20 °C
<b>Temperature range</b>	0 °C ÷ 60 °C
<b>Reference standards</b>	<b>Construction criteria:</b> EN ISO 16137, EN ISO 1452, EN ISO 15493 <b>Test methods and requirements:</b> ISO 9393 <b>Installation criteria:</b> DVS 2204, DVS 2221, UNI 11242
<b>Valve material</b>	PVC-U
<b>Seal material</b>	EPDM (standard size O-Ring)
<b>Spring material (SSE)</b>	Available in STAINLESS Steel 316, A316 PTFE encapsulated



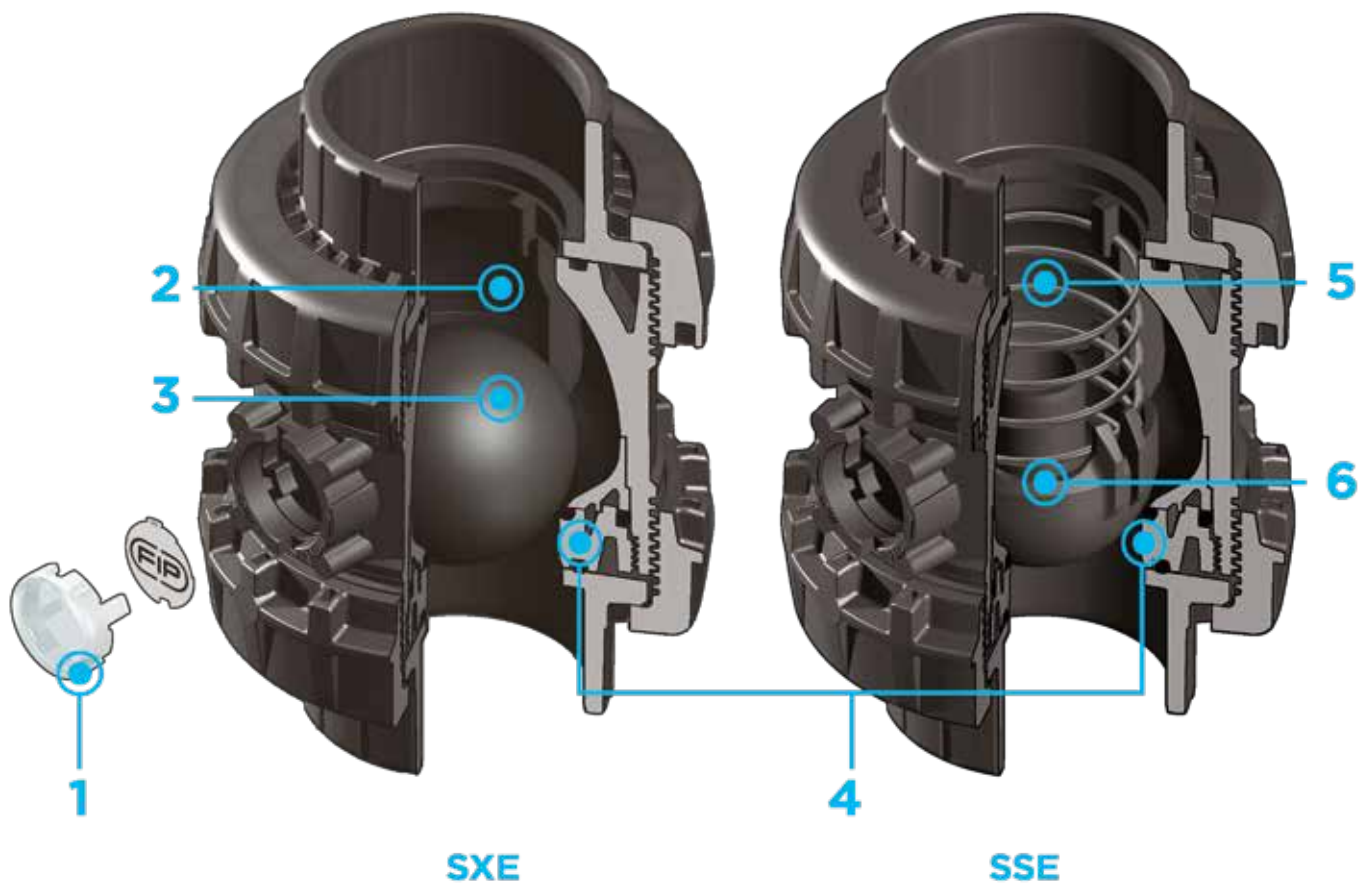

- 1 Customisable Labelling System:** built-in LCE module on the valve body made up of transparent protection plug and customisable tag holder using the LSE set (available as accessory). The customisation potential lets you **identify the valve on the system** according to specific needs
- 2 Optimised dynamic fluid design:** energy savings due to the improved valve Kv value and consequent reduced pressure drop
- 3 High surface finish ball shutter:** **reduced wear**, longer working life and reduced valve maintenance. Ideal to convey dirty fluids, even with suspended fluids or filaments, thanks to the special design that permits **internal valve selfcleaning**
- 4 Locked ball seat carrier:** safe dismantling for maintenance with the Easyfit multifunctional handle
- 5 Ideal for horizontal installations:** **perfect seal even with low back pressure. Silent** and durable even with strong vibrations and pulsating fluid
- 6 PVC-U shutter and springs** available in STAINLESS Steel 316, A316 PTFE encapsulated: maximum reliability in a **wide field of applications** from salt water to aggressive acids

# TECHNICAL DATA

## PRESSURE VARIATION ACCORDING TO TEMPERATURE

For water and harmless fluids to which the material is classified as CHEMICALLY RESISTANT. In other cases, a reduction of the nominal PN pressure is required (25 years with safety factor).



## PRESSURE DROP GRAPH

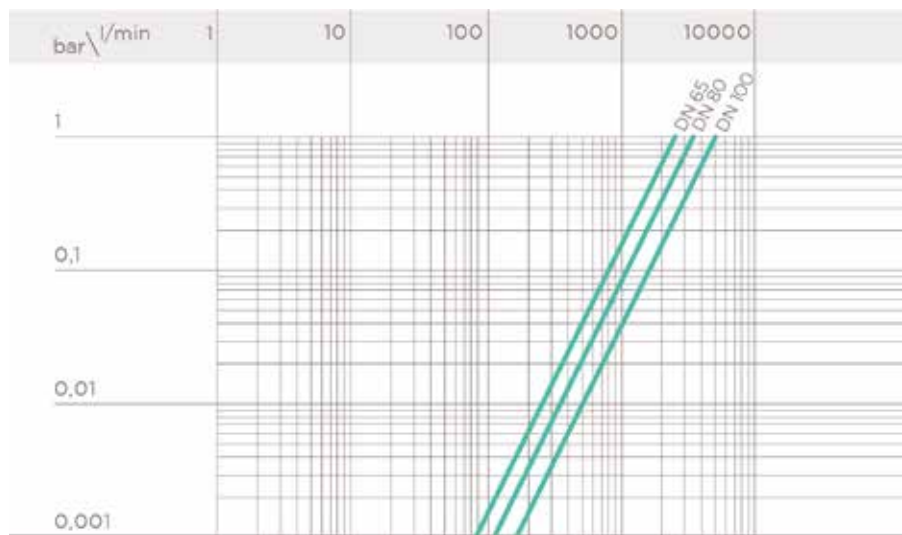

## K<sub>v</sub>100 FLOW COEFFICIENT

The K<sub>v</sub>100 flow coefficient is the Q flow rate of litres per minute of water at a temperature of 20°C that will generate Δp= 1 bar pressure drop at a certain valve position. The Kv100 values shown in the table are calculated with the valve completely open.

DN	65	80	100
Kv100 l/min	2586	3444	5093

## MINIMUM VALVE SEALING PRESSURE

The PVC-U SXE valve can only be used with liquids with specific weight under 1,37g/cm<sup>3</sup>.

DN	65	80	100
SXE (bar)	0,2	0,2	0,2
SSE (bar)	0,08	0,08	0,08

The information in this leaflet is provided in good faith. No liability will be accepted concerning technical data that is not directly covered by recognised international standards. FIP reserves the right to carry out any modification. Products must be installed and maintained by qualified personnel.

# DIMENSIONS



## SXEBEV

Easyfit ball check valve with PE100 SDR 11 male end connectors for butt welding or electrofusion (CVDE)

d	DN	PN	E	H	L	Z	g	EPDM code
75	65	16	157	331	71	189	2605	SXEBEV075E
90	80	16	174	367	88	191	3300	SXEBEV090E
110	100	16	212	407	92	223	5770	SXEBEV110E



## SSEBEV

Easyfit spring check valve with PE100 SDR 11 male end connectors for butt welding or electrofusion (CVDE)

d	DN	E	H	L	Z	g	PN	EPDM code
75	65	157	331	71	189	2480	16	SSEBEV075E
90	80	174	367	88	191	3090	16	SSEBEV090E
110	100	212	407	92	223	5370	16	SSEBEV110E

# ACCESSORIES

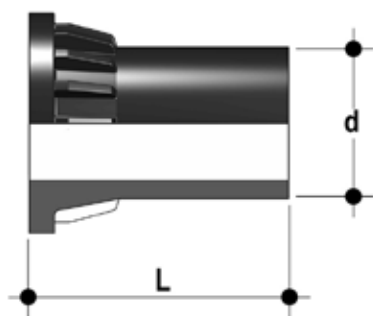

## CVDE

Long spigot PE100 end connectors for joints with electrofusion fittings or for butt welding

d	DN	PN	L	SDR	Code
75	65	16	111	11	CVDE11075
90	80	16	118	11	CVDE11090VXE
110	100	16	127	11	CVDE11110VXE



## EASYFIT HANDLE DN 65÷100

Easyfit multifunctional handle for union nut tightening SXE-SSE DN 65÷100

d	DN	Code
75	65	HSVXE075
90	80	HSVXE090
110	100	HSVXE110



## LSE

Customisation and label printing set for Easyfit handle made up of precut adhesive sheets and software for guided label creation.

d	DN	SXE - SSE code
75	65	LSE063
90	80	LSE063
110	100	LSE063

# CUSTOMISATION



SXE and SSE DN 65÷100 Easyfit valves are equipped with a customisable Labelling System.

This system lets you create special labels to affix to the valve body. This makes it extremely easy to apply company logos, identification serial numbers or service indications such as, for example, the valve function in the system, the transported fluid, but also specific information for customer service, such as the customer name or installation date or location on the valves.

The specific LCE module is a standard supply and is made up of a rigid transparent water-resistant PVC plug and white tag holder made of the same material, one side of which bears the FIP logo.

The holder, inserted in the plug, can be removed and, once overturned, used for customisation by applying labels printed with the software supplied with the LSE set.

Proceed as follows to apply the label on the valve:

- 1) Remove the transparent plug from the housing on the valve body.
- 2) Extract the tag holder from the transparent plug.
- 3) Apply the adhesive label on the holder to align the profiles matching the tab position.
- 4) Reinsert the tag holder in the transparent plug so that the label is protected against the elements.
- 5) Replace the transparent plug in its seat on the valve body.

# COMPONENTS

## EXPLODED VIEW

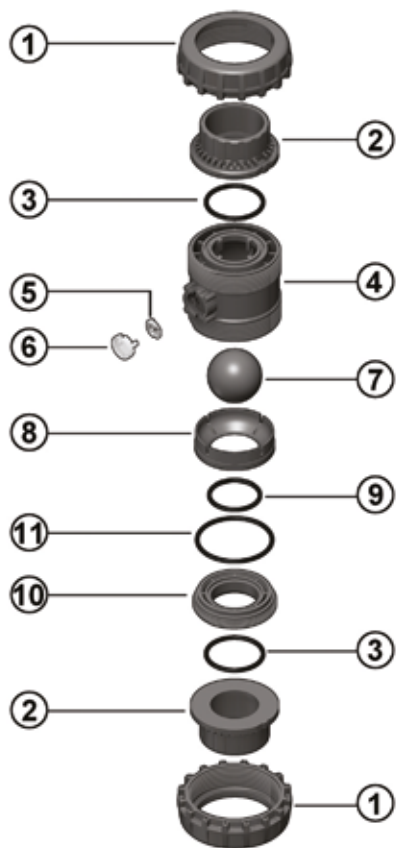

**SXE**

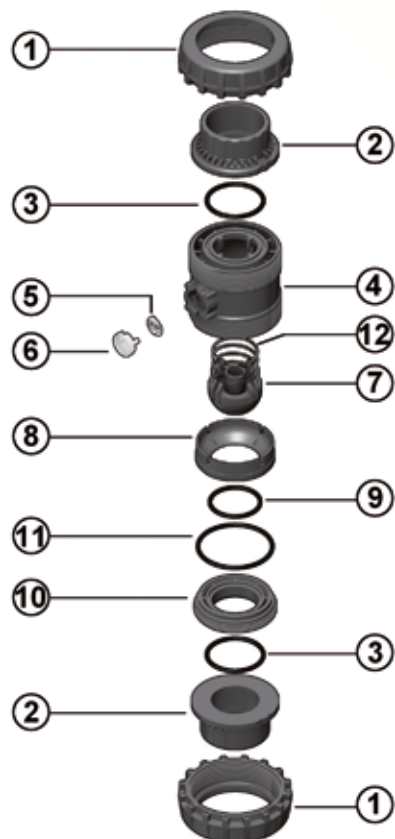

**SSE**

- 1** Union nut (PVC-U - 2)
- 2** End connector (PVC-U - 2)
- 3** Socket seal O-Ring (EPDM, FKM - 2)
- 4** Body (PVC-U - 1)
- 5** Tag holder (PVC - 1)
- 6** Transparent protection plug (PVC - 1)

- 7** Ball (PVC-U - 1)
- SXE**
- 7** Shutter (PVC-U - 1)
- SSE**
- 8** Gland packing ring (PVC-U - 1)
- 9** Ball seat O-Ring (EPDM, FKM - 1)
- SXE**

- 9** Shutter gasket (EPDM, FKM - 1)
- SSE**
- 10** Ball seat carrier (PVC-U - 1)
- SXE**
- 10** Shutter seat O-ring (PVC-U - 1)
- SSE**
- 11** Radial seal O-Ring (EPDM,FKM - 1)
- 12** Spring (STAINLESS steel\* - 1)

\* Also available made of A316 PTFE encapsulated  
The component material and quantity supplied are indicated in the parentheses.

## DISASSEMBLY

### SXE

SXE valves do not require maintenance in normal operating conditions. In the event of leaks or wear, before performing maintenance, cut-off fluid upstream from the valve and make sure it is de-pressurised (downstream drain if necessary).

- 1) Fully drain residual liquid that could be aggressive for the operator and, if possible, circulate water to internally clean the valve.
- 2) For easy union nut tightening in assembly, use the Easyfit multifunctional handle (supplied as an accessory).
- 3) Unscrew the ball seat carrier (10) with the Easyfit multifunctional handle: introduce the two protrusion on the top of the handle in the grooves in the carrier (10) and unscrew, extracting it counter-clockwise.
- 4) Remove all internal components.

### SSE

In the event of leaks or wear, before performing maintenance, cut-off fluid upstream from the valve and make sure it is de-pressurised (downstream drain if necessary).

- 1) Fully drain residual liquid that could be aggressive for the operator and, if possible, circulate water to internally clean the valve.
- 2) For easy union nut tightening in assembly, use the Easyfit multifunctional handle (supplied as an accessory).
- 3) Unscrew the ball seat carrier (10) with the Easyfit multifunctional handle: introduce the two protrusion on the top of the handle in the grooves in the carrier (10) and unscrew, extracting it counter-clockwise.
- 4) Remove all internal components.

## ASSEMBLY

### SXE

- 1) Reconstruct the valve following the exploded view on the previous page.
- 2) Tighten the ball seat carrier (10) using the Easyfit multifunctional handle. This ensures optimal valve installation and operations (fig. 3).
- 3) Position the valve between the end connectors (2) and tighten the union nuts clockwise (1) using the Easyfit multifunctional handle (fig. 7) being sure the socket seal O-ring (3) does not exit the seats.

### SSE

- 1) Reconstruct the valve following the exploded view on the previous page.
- 2) Tighten the ball seat carrier (10) using the Easyfit multifunctional handle. This ensures optimal valve installation and operations (fig. 3).
- 3) Position the valve between the end connectors (2) and tighten the union nuts clockwise (1) using the Easyfit multifunctional handle (fig. 7) being sure the socket seal O-ring (3) does not exit the seats.



**Note:** during assembly operations, it is advisable to lubricate the rubber seals. Mineral oils are not recommended for this task as they react aggressively with EPDM rubber.

Fig. 1



Fig. 2



Fig. 3



Fig. 4



# INSTALLATION

SXE and SSE valves can be installed both vertically (upward flow) and horizontally (SXE with minimum 0.2 bar back pressure).

Before proceeding with installation, please follow these instructions carefully:

- 1) Check that the pipes to be connected to the valve are aligned in order to avoid mechanical stress on the threaded joints.
- 2) Unscrew the union nuts (1) from the body (4) and insert them in the pipe segments.
- 3) Solvent weld or screw the end connectors (2) onto the pipe segments.
- 4) Position the valve body between the end connectors (fig. 1).
- 5) Place the union nuts on the valve body and start tightening manually clockwise until they are hard to turn. Do not use wrenches or other tools that can damage the union nut surface (fig. 2).
- 6) For easy union nut tightening in assembly, use the Easyfit multifunctional handle (supplied as an accessory).
- 7) Extract the hooked insert in the handle (fig. 5) overturn it and fit it in the seat on the lower part of the handle (fig. 6).
- 8) Fit the tool on the external union nut profile until firmly and safely secured that allows for adequate torque without damaging the union nut in any way (fig. 7).
- 9) Repeat point 7 for the other union nut.
- 10) When tightened, remove the hooked insert and replace it in its seat in the handle.
- 11) If necessary, support the pipe with FIP pipe clip model ZIKM and DSM distance plates.

## WARNINGS

Do not use compressed air or other gases to test thermoplastic lines. Always avoid sudden closing manoeuvres and protect the valve against accidental manoeuvres.

Leave a straight section of pipe of length equal to 5 times the nominal diameter before and after the valve.

Fig. 5



Fig. 6



Fig. 7







# FE DN 40÷200

The FE is a butterfly valve for shutting off or regulating flow, specifically designed for water applications and equipped with a customisable Labelling System.

## BUTTERFLY VALVE

- Disk in PVC-U with through shaft
- **Zinc plated square section steel stem completely isolated from the fluid** complying with standard ISO 5211: DN 40 ÷ 65: 11 mm DN 80 ÷ 100: 14 mm DN 125 ÷ 150: 17 mm DN 200: 22 mm
- Can also be installed as a bottom discharge valve or tank dump valve
- **Valve material compatibility** (PVC-U) with water conveyance, drinking water and other food substances according to **current regulations**
- Possibility of directly installing a gearbox or pneumatic and/or electric actuators with a standard drilling pattern according to standard ISO 5211 F05, F07, F10

Technical specifications	
<b>Construction</b>	Bi-directional centric butterfly valve
<b>Size range</b>	DN 40 ÷ 200
<b>Nominal pressure</b>	<b>Wafer version</b> <b>DN 40 ÷ 50:</b> PN 16 with water at 20 °C <b>DN 65÷200:</b> PN 10 with water at 20 °C
<b>Temperature range</b>	0 °C ÷ 60 °C
<b>Reference standards</b>	<b>Flanging system:</b> EN ISO 1452, EN ISO 15493, ISO 7005-1, EN 1092-1, ANSI B16.5 Cl.150, JIS B2220
<b>Riferimenti Reference standards</b>	<b>Construction criteria:</b> EN ISO 16136, EN ISO 1452, EN ISO 15493 <b>Test methods and requirements:</b> ISO 9393 <b>Actuator couplings:</b> ISO 5211
<b>Valve material</b>	<b>Body:</b> PVC-U <b>Disk:</b> PVC-U <b>Stem:</b> Zinc plated carbon steel (C45). On request STAINLESS steel AISI 316
<b>Seal material</b>	Liner: EPDM. On request NBR
<b>Control options</b>	Hand lever operated; Gearbox, pneumatic actuator, electric actuator

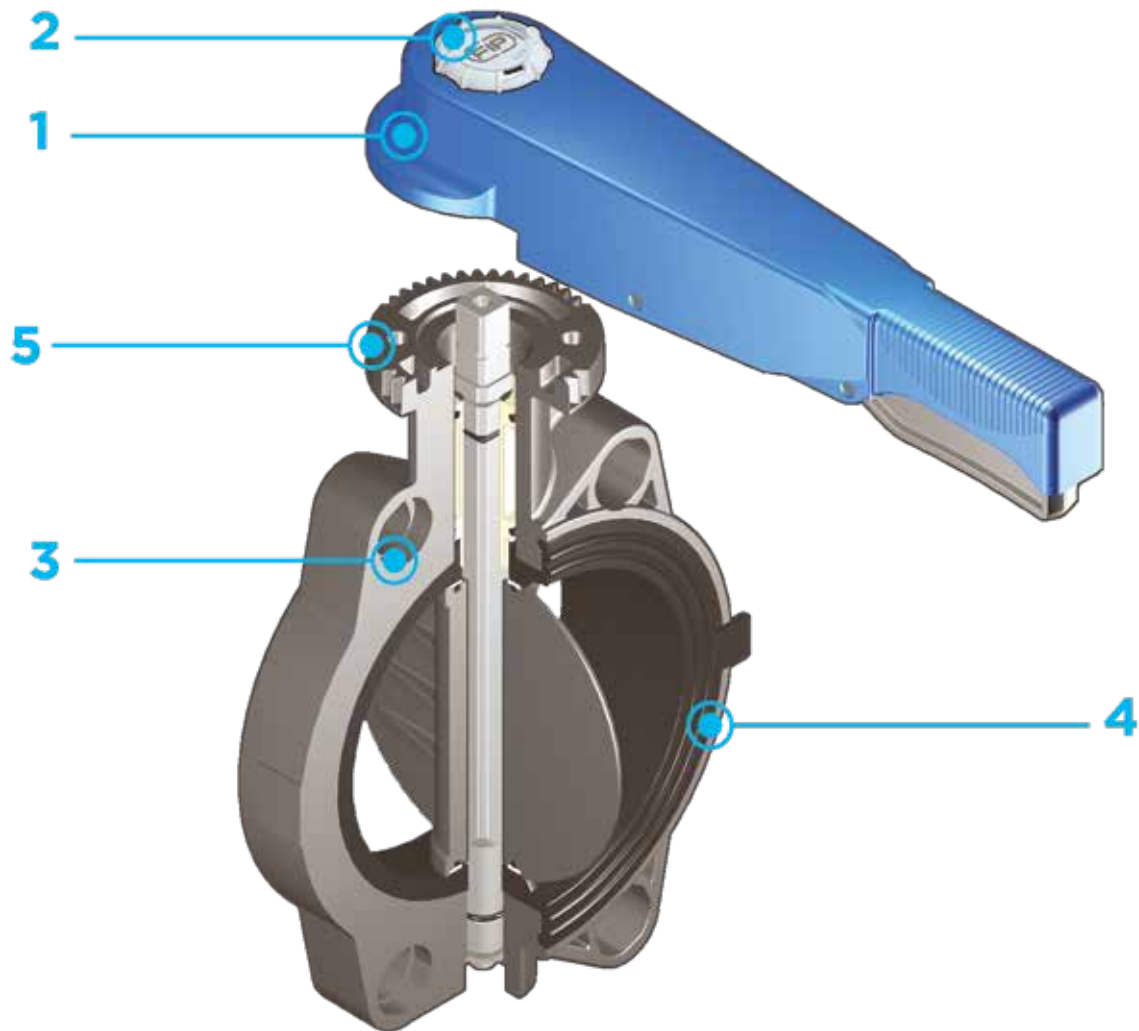

**1 Ergonomic multifunctional handle in HIPVC** with the option for **quick operation, graduated adjustment** in 12 positions (every 7.5°). 180° reversible mounting

**2 Customisable Labelling System:** integrated module, made of a transparent protection plug customisable tag holder using the LSE set (available as accessory).

**The customisation lets you identify the valve on the system** according to the specific needs

**3 Drilling pattern with oval slots** that allow coupling to flanges according to numerous international standards

**4 Interchangeable liner** with

the dual function of forming a hydraulic seal and isolating the body from the fluid.

**5 One-piece top flange** with PVC-U rack. Drilling according to standard ISO 5211 for direct drive:  
 DN 40 ÷ 65: F05  
 DN 80 ÷ 150: F07  
 DN 200: F10

# TECHNICAL DATA

## PRESSURE VARIATION ACCORDING TO TEMPERATURE

For water and non-hazardous fluids with regard to which the material is classified as CHEMICALLY RESISTANT. In other cases, a reduction of the nominal pressure PN is required (25 years with safety factor).

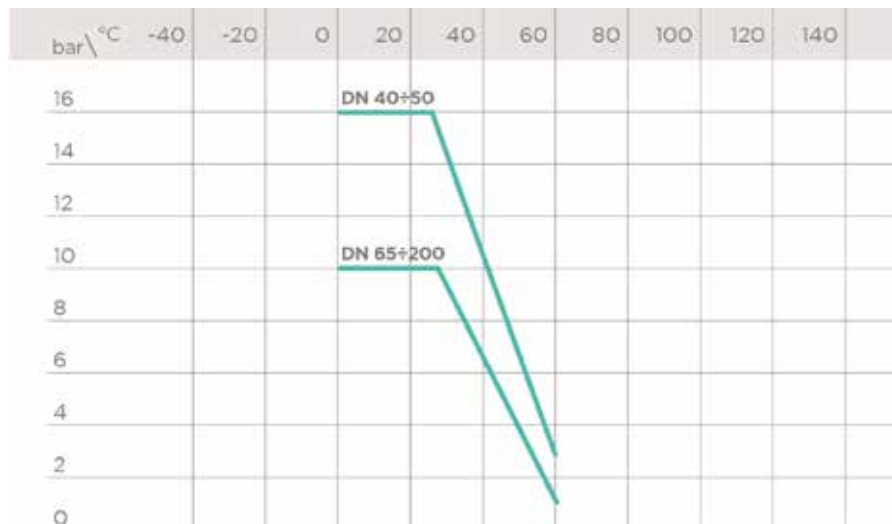

## PRESSURE DROP GRAPH

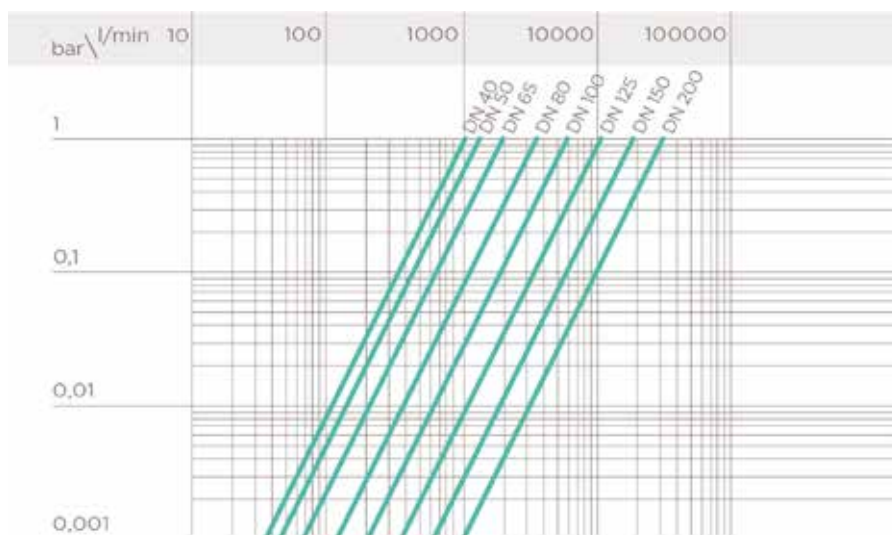

## K<sub>v</sub> 100 FLOW COEFFICIENT

The K<sub>v</sub>100 flow coefficient is the Q flow rate of litres per minute of water at a temperature of 20°C that will generate Δp= 1 bar pressure drop at a certain valve position. The Kv100 values shown in the table are calculated with the valve completely open.

DN	40	50	65	80	100	125	150	200
Kv100 l/min	1000	1285	1700	3550	5900	9850	18700	30500

## RELATIVE FLOW COEFFICIENT GRAPH

The relative flow coefficient is the flow rate through the valve as a function of the degree of valve opening.

Horizontal axis: Percentage opening of the disk

Vertical axis: Relative flow coefficient

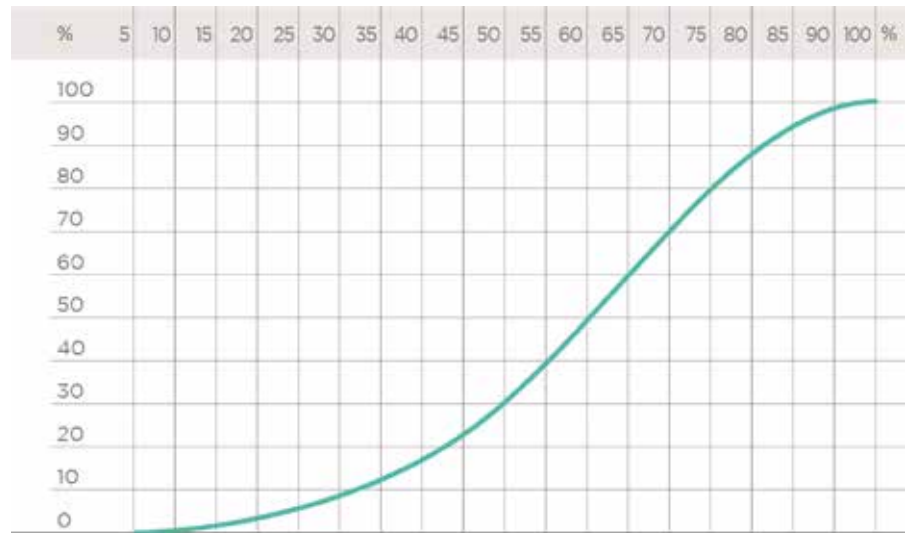

## OPERATING TORQUE AT MAXIMUM WORKING PRESSURE

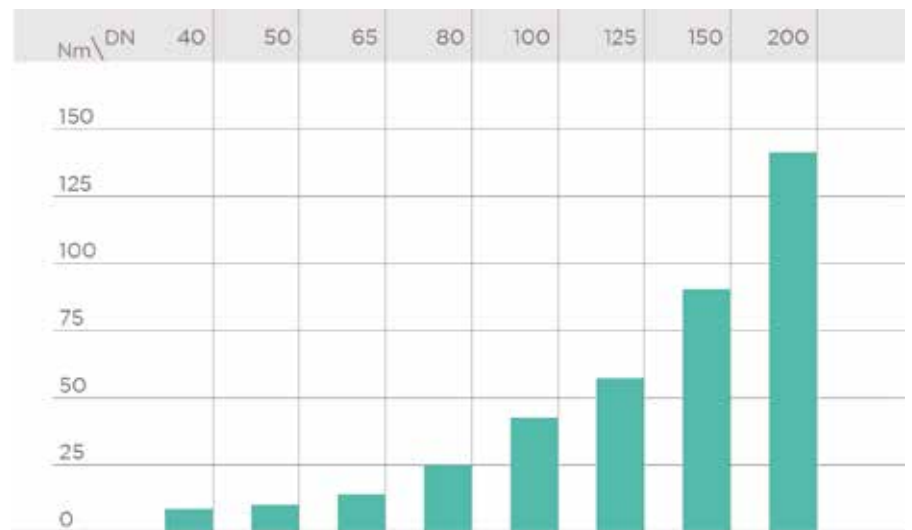

# DIMENSIONS

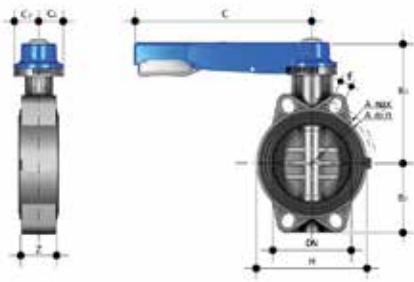

## FEOV/LM

Hand operated Butterfly valve

d	DN	PN	A min	A max	B <sub>2</sub>	B <sub>3</sub>	C	C <sub>1</sub>	C <sub>2</sub>	f	H	U	Z	g	EPDM code
50 - 1 1/2	40	16	93,5	109	60	136	175	45	42	19	132	4	33	827	FEOVLM050E
63 - 2"	50	16	108	124	70	143	175	45	42	19	147	4	43	1012	FEOVLM063E
75 - 2 1/2	65	10	128	144	80	168	175	45	45	19	165	4	46	1420	FEOVLM075E
90 - 3"	80	10	145	159	90	182	250	45	45	19	130	4	49	1640	FEOVLM090E
110 - 4"	100	10	165	190	105	196	250	45	45	19	150	4	56	1990	FEOVLM110E
*125 - 5"	125	10	204	215	121	215	335	45	45	23	185	4	64	3030	FEOVLM140E
*140 - 5"	125	10	204	215	121	215	335	45	45	23	185	4	64	3030	FEOVLM140E
160 - 6"	150	10	230	242	132	229	335	45	45	23	210	4	70	3730	FEOVLM160E
**200 - 8"	200	10	280	298	161	309	425	65	82	23	325	8	71	8240	FEOVLM225E
**225 - 8"	200	10	280	298	161	309	425	65	82	23	325	8	71	8240	FEOVLM225E

Note:

FE is suitable for flanged JIS K10 wafer installation in the range DN40 (1 1/2") - DN150 (6")

\* d125, FEOV d140 with special QPV FE-FK d125 for butterfly valve (QPV125FKE)

\*\* d200, FEOV d225 with special QPV FE-FK d200 for butterfly valve (QPV200FKE)



## FEOV/RM

Gearbox operated Butterfly valve

d	DN	PN	B <sub>2</sub>	B <sub>5</sub>	B <sub>6</sub>	G	G1	G <sub>2</sub>	G <sub>3</sub>	U	g	EPDM code
75 - 2 1/2	65	10	80	173	145	48	135	39	125	4	2380	FEOVRM075E
90 - 3"	80	10	90	187	159	48	135	39	125	4	2600	FEOVRM090E
110 - 4"	100	10	105	201	173	48	135	39	125	4	2950	FEOVRM110E
*125 - 5"	125	10	121	220	192	48	144	39	200	4	4400	FEOVRM140E
*140 - 5"	125	10	121	220	192	48	144	39	200	4	4400	FEOVRM140E
160 - 6"	150	10	132	235	207	48	144	39	200	4	5100	FEOVRM160E
**200 - 8"	200	10	161	288	257	65	175	60	200	8	9260	FEOVRM225E
**225 - 8"	200	10	161	288	257	65	175	60	200	8	9260	FEOVRM225E

Note:

FE is suitable for flanged JIS K10 wafer installation in the range DN40 (1 1/2") - DN150 (6").

\* d125, FEOV d140 with special QPV FE-FK d125 for butterfly valve (QPV125FKE)

\*\* d200, FEOV d225 with special QPV FE-FK d200 for butterfly valve (QPV200FKE)

# ACCESSORIES



## LSE

Customisation and label printing set for Easyfit handle made up of pre-cut adhesive sheets and software for guided label creation.

d	DN	total labels	N° of sheets	FE*- FK* code
50	40	500	10	LSE040
63	50	500	10	LSE040
75	65	500	10	LSE040
90	80	500	10	LSE040
110	100	500	10	LSE040
125-140	125	500	10	LSE040
160	150	500	10	LSE040
200-225	200	500	10	LSE040

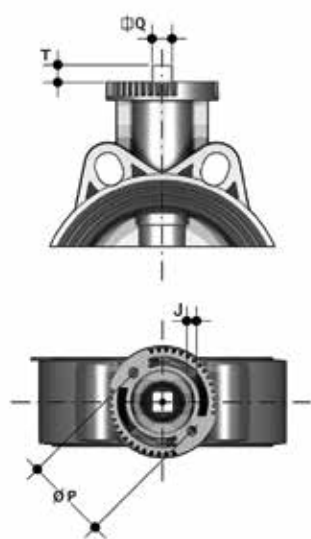

## ACTUATOR MOUNTING FLANGE

The valve can be equipped with standard pneumatic or electric actuators and gearbox for heavy-duty operations

DN	J	P	Ø	T	Q
40	7	50	F 05	12	11
50	7	50	F 05	12	11
65	7	50	F 05	12	11
80	9	70	F 07	16	14
100	9	70	F 07	16	14
125	9	70	F 07	19	17
150	9	70	F 07	19	17
200*	11	102	F 10	24	22

\*using a flange in PP-GR reproducing the drilling pattern provided for by standard ISO 5211.

# CUSTOMISATION

Fig. 1



Fig. 2



The FE valve is equipped with the customisable Labelling System.

This system lets you create special labels to insert in the handle. This makes it extremely easy to apply company logos, identification serial numbers or service information such as, for example, the valve function in the system, the transported fluid, but also specific information for customer service, such as the customer name or installation date or location on the valves.

The specific LCE module is a standard supply and is made up of a rigid transparent water-resistant PVC plug (A-C) and white tag holder (B) made of the same material, one side of which bears the FIP logo (fig. 1).

The tag holder, inserted in the plug, can be removed and, once overturned, used for customisation by applying labels printed with the software supplied with the LSE set.

Proceed as follows to apply the label on the valve:

- 1) Remove the upper part of the transparent plug (A) rotating it counter-clockwise as indicated by the word "Open" on the plug and remove it.
- 2) Extract the tag holder from its housing on the lower part of the plug (C)
- 3) Apply the adhesive label on the holder (B) to align the profiles matching the tab position.
- 4) Reinsert the tag holder in its housing at the bottom of the plug
- 5) Reposition the top of the plug in the housing rotating it clockwise; this way the label is protected against the elements.



# COMPONENTS

## EXPLODED VIEW DN 40÷50

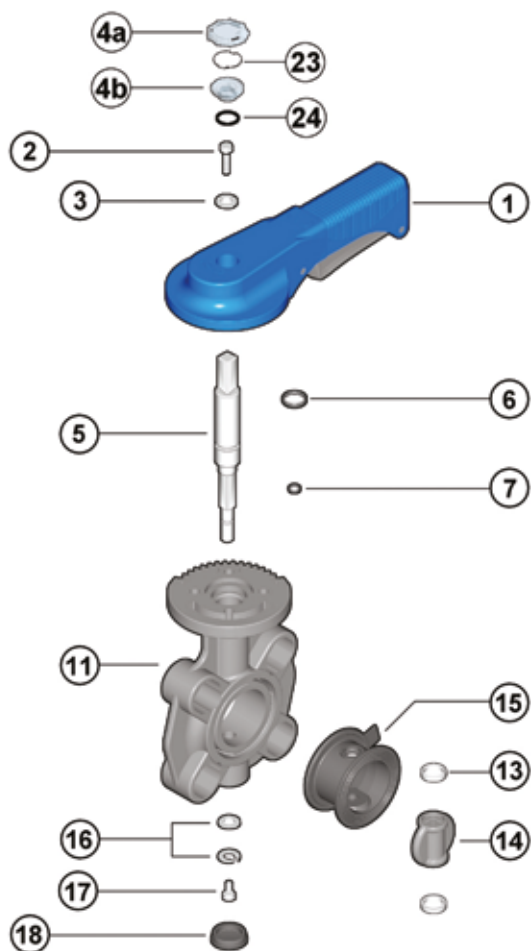

- |             |                                       |           |                               |           |                             |
|-------------|---------------------------------------|-----------|-------------------------------|-----------|-----------------------------|
| <b>1</b>    | Handle (HIPVC - 1)                    | <b>6</b>  | Stem O-Ring (EPDM or FKM - 1) | <b>16</b> | Washer (Steel - 1)          |
| <b>2</b>    | Screw (STAINLESS steel - 1)           | <b>7</b>  | Stem O-Ring (EPDM or FKM - 1) | <b>17</b> | Screw (STAINLESS steel - 1) |
| <b>3</b>    | Washer (STAINLESS steel - 1)          | <b>11</b> | Body (PVC-U - 1)              | <b>18</b> | Protection plug (PE - 1)    |
| <b>4a/b</b> | Transparent protection plug (PVC - 1) | <b>13</b> | Anti-friction ring (PTFE - 2) | <b>23</b> | Tag holder (PVC-U - 1)      |
| <b>5</b>    | Stem (Zinc plated steel - 1)          | <b>14</b> | Disk (PVC-U - 1)              | <b>24</b> | O-Ring (NBR - 2)            |
|             |                                       | <b>15</b> | Liner (EPDM o FKM - 1)        |           |                             |

The material of the component and the quantity supplied are indicated between brackets

## EXPLODED VIEW DN 65÷200

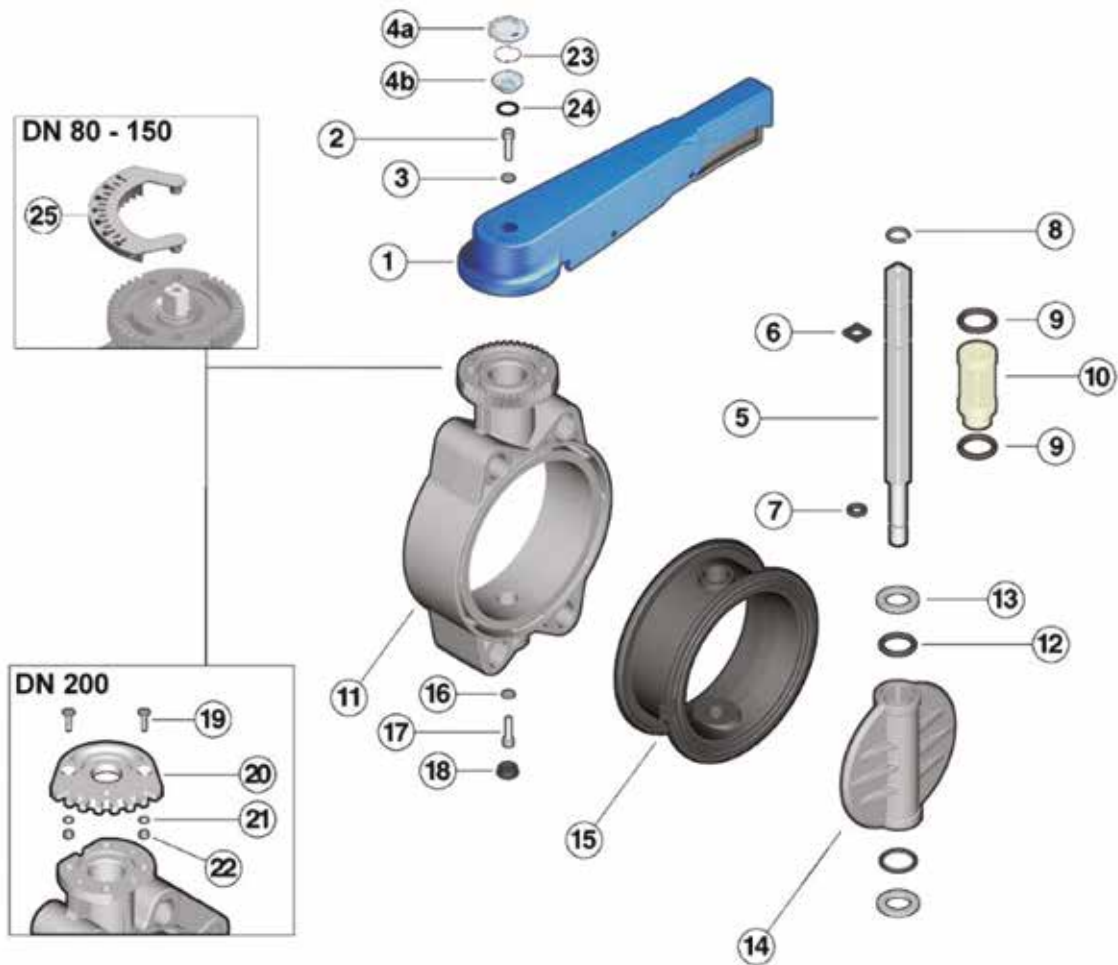

- |             |                                       |           |                               |           |                               |
|-------------|---------------------------------------|-----------|-------------------------------|-----------|-------------------------------|
| <b>1</b>    | Handle (HIPVC - 1)                    | <b>9</b>  | Bush O-Ring (EPDM or FKM - 2) | <b>18</b> | Protection plug (PE - 1)      |
| <b>2</b>    | Screw (STAINLESS steel - 1)           | <b>10</b> | Bush (Nylon - 1)              | <b>19</b> | Screw (STAINLESS steel - 2)   |
| <b>3</b>    | Washer (STAINLESS steel - 1)          | <b>11</b> | Body (PVC-U - 1)              | <b>20</b> | Plate (PVC-U - 1)             |
| <b>4a/b</b> | Transparent protection plug (PVC - 1) | <b>12</b> | Disk O-Ring (EPDM or FKM - 2) | <b>21</b> | Washer (STAINLESS steel - 2)  |
| <b>5</b>    | Stem (Zinc plated steel - 1)          | <b>13</b> | Anti-friction ring (PTFE - 2) | <b>22</b> | Nut (STAINLESS steel - 2)     |
| <b>6</b>    | Stem O-Ring (EPDM or FKM - 1)         | <b>14</b> | Disk (PVC-U - 1)              | <b>23</b> | Tag holder (PVC-U - 1)        |
| <b>7</b>    | Stem O-Ring (EPDM or FKM - 1)         | <b>15</b> | Liner (EPDM o FKM - 1)        | <b>24</b> | O-Ring (NBR - 2)              |
| <b>8</b>    | Seeger ring (STAINLESS steel - 2)     | <b>16</b> | Washer (Steel - 1)            | <b>25</b> | Position indicator (PVC-U- 1) |
|             |                                       | <b>17</b> | Screw (STAINLESS steel - 1)   |           |                               |

The material of the component and the quantity supplied are indicated between brackets

## DISASSEMBLY

- 1) Remove the LCE module consisting of the rigid transparent PVC plug (4a- 4b) and white tag holder (23) and remove screw (2) and washer (3).
- 2) Remove the handle (1).
- 3) Remove the protection plug (18) and screw (17) with the washer (16).
- 4) Extract the stem (5) and disk (14).
- 5) Remove the liner (15) from the body (11).
- 6) Remove the Seeger ring (8) and guide bush (10).
- 7) Remove O-rings (6) and (7).

## ASSEMBLY

- 1) Place the liner (15) on the body (11).
- 2) Insert O-rings (6) and (7) on the stem (5).
- 3) Insert the gaskets (9) on the guide bush (10) and the bush on the stem. Lock the bush using the Seeger ring (8).
- 4) Position the O-rings (12) and then the anti-friction rings (13) on the disk (14) and the disk inside the body, after having lubricated the liner (15).
- 5) Insert the stem (5) through the body (11) and disk (14).
- 6) Tighten screw (17) with washer (16) and insert the protection plug (18).
- 7) Position the handle (1) on the stem.
- 8) Tighten screw (2) with washer (3) and replace the LCE module consisting of the rigid transparent PVC plug (4a-4b) and white tag holder protection(23).



**Note:** during assembly operations, it is advisable to lubricate the rubber seals. Mineral oils are not recommended for this task as they react aggressively with EPDM rubber.

# INSTALLATION

## JOINTS

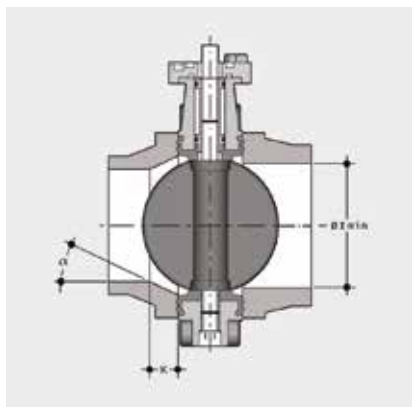

Before proceeding with the installation of the stubs, check that the bore of the fittings has sufficient clearance to allow the valve disk to open correctly. Also check the maximum coupling distance for the liner. Before proceeding with the installation of the FE valve, check that the bore of the stubs allows the correct opening of the disk

DN	l min.
40	25
50	28
65	47
80	64
100	84
125	108
150	134
200	187

## PVC-U STUBS

To install on PVC-U stubs, check the valve-stub-flange couplings in the following table.

	d	DN	50	63	75	90	110	125	140	160	200	225
			40	50	65	80	100	100	125	150	200	200
FE	50	40										
	63	50										
	75	65										
	90	80										
	110	100										
	140	125						*				
	160	150										
	225	200									**	

Stub with female end for solvent welding according to EN ISO 1452  
 \* With special stub d125 DN 125 for FE d140 DN 125 and flange d140 DN 125  
 \*\* With special stub d200 DN 200 for FE d225 DN 200 and flange d225 DN 200

## PP-PE STUBS

For the installation of PP-PE stubs, for butt welding a short spigot or electrofusion/butt welding a long spigot, check the valve-stub couplings and the K - a chamfer dimensions where necessary according to the different SDR's in the following table.

	d	DN	50	63	75	90	110	125	140	160	180	200	225	250	280	315
			40	50	65	80	100	100	125	150	150	200	200	250	250	300
FE	50	40														
	63	50														
	75	65														
	90	80														
	110	100														
	140	125														
	160	150														
	225	200														
SDR	17/17,6											k=26,5 a=20°		k=15,7 a=25°		k=13,3 a=25°
	11									k=35 a=20°		k=35 a=25°	k=40 a=15°	k=32,5 a=25°	k=35 a=25°	k=34,5 a=25°
	7,4				k=10 a=35°	k=15 a=35°		k=20 a=30°	k=35 a=20°	k=15 a=35°	k=40 a=20°	k=35 a=30°	k=55 a=30°	k=35 a=30°	k=65 a=30°	

Short/long spigot stubs according to EN ISO 15494

## TIGHTENING THE STUD-BOLTS

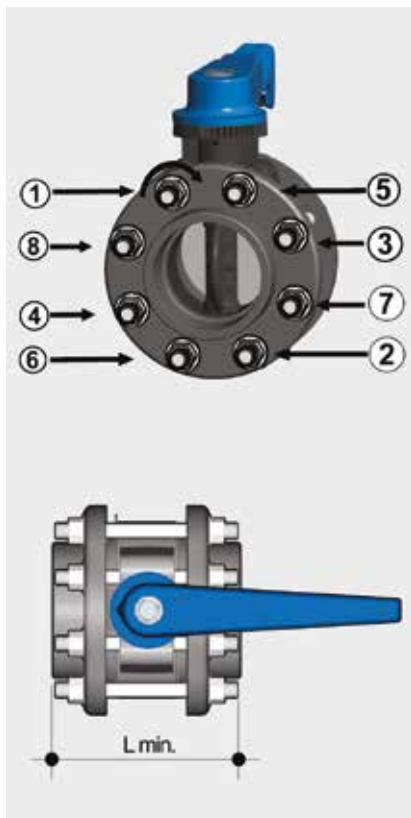

Before tightening the stud-bolts, it is advisable to open the disk in order to prevent damage to the seal. Tighten the stud-bolts in a uniform manner, in the order indicated in the figure, to the operating torque value indicated in the table. The stud-bolts do not need to be excessively tightened in order to produce a perfect hydraulic seal.

Overtightening could adversely affect the operating torque of the valve

DN	L min.	*Nm
40	M16 x150	9
50	M16 x150	12
65	M16 x170	15
80	M16 x180	18
100	M16 x180	20
125	M16 x210	35
150	M20 x 240	40
200	M20 x 260	55

\* Tightening torques for nuts and bolts on couplings with backing ring.  
Values required to obtain the hydraulic test (1.5xPN at 20°C)  
(new or lubricated nuts and bolts)

## JIS FLANGED OPTIONS

FE is suitable for flanged JIS K10 wafer installation in the range DN40 (1"1/2) - DN150 (6") and in JIS K5 in the range DN40 (1"1/2) - DN200 (8").



# FK DN 40÷400

The FK is a butterfly valve for shutting off or regulating flow, with structural characteristics that make it ideal for industrial applications requiring high performance and longterm reliability. This valve is also equipped with the customisable Labelling System.

## BUTTERFLY VALVE

- Interchangeable disk in PVC-U with through shaft, available in different thermo-plastic materials: PP-H, PVC-C, ABS, PVDF
- Overall dimensions of the valve in accordance with standard ISO 5752 and EN 558 (DN 40÷65 and DN 250÷350 Long Series 16, DN 80÷200 Medium Series 25, DN 400 according to internal specifications)
- Can also be installed as an end line valve, bottom discharge valve or tank dump valve
- **Special Lug version** PN 10 fully drilled to EN 1092-1 or ANSI B16.5 cl.150 with **molded-in AISI 316 STAINLESS steel threaded inserts**
- **Valve material compatibility** (PVC-U + EPDM) with water conveyance, drinking water and other food substances according to **current regulations**
- Possibility of installing a manual reducer or pneumatic and/or electric actuators by applying an ISO standard drilling PP-GR flanges. DN 40 ÷ 200 valve fitted with plate with rack in PP-GR. For actuated versions with flange drilled according to ISO 5211 F05, 07, F10. DN 250÷400 valve, fitted with one-piece top flange in high mechanical strength PP-GR with mounting flange for internal components drilled according to standard ISO 5211 F10 (excluding DN 350÷400), F12, F14.
- Possibility to have handle with integrated LSQT limit micro switch, even as a retrofit in existing installations

Technical specifications	
<b>Construction</b>	Bi-directional centric butterfly valve
<b>Size range</b>	DN 40 ÷ 400
<b>Nominal pressure</b>	<b>Wafer version</b> <b>DN 40 ÷ 50:</b> PN16 with water at 20 °C <b>DN 65÷250:</b> PN 10 with water at 20 °C <b>DN 300:</b> PN 8 with water at 20 °C <b>DN 350:</b> PN 7 with water at 20 °C <b>DN 400:</b> PN 6 with water at 20 °C <b>Lug version</b> <b>DN 65÷200:</b> PN 10 with water at 20 °C <b>DN 250÷300:</b> PN 6 with water at 20 °C
<b>Temperature range</b>	0 °C ÷ 60 °C
<b>Coupling standards</b>	<b>Flanging system:</b> EN ISO 1452, EN ISO 15493, ISO 7005-1, EN 1092-1, ANSI B16.5 Cl.150, JIS B2220
<b>Reference standards</b>	<b>Construction criteria:</b> EN ISO 16136, EN ISO 1452, EN ISO 15493 <b>Test methods and requirements:</b> ISO 9393 <b>Actuator couplings:</b> ISO 5211
<b>Valve material</b>	<b>Body:</b> PP-GR <b>Disk:</b> PVC-U <b>Stem:</b> Stainless Steel AISI 316
<b>Seal material</b>	Liner: EPDM.
<b>Control options</b>	Hand lever operated (DN 40÷200); Gearbox, pneumatic actuator, electric actuator



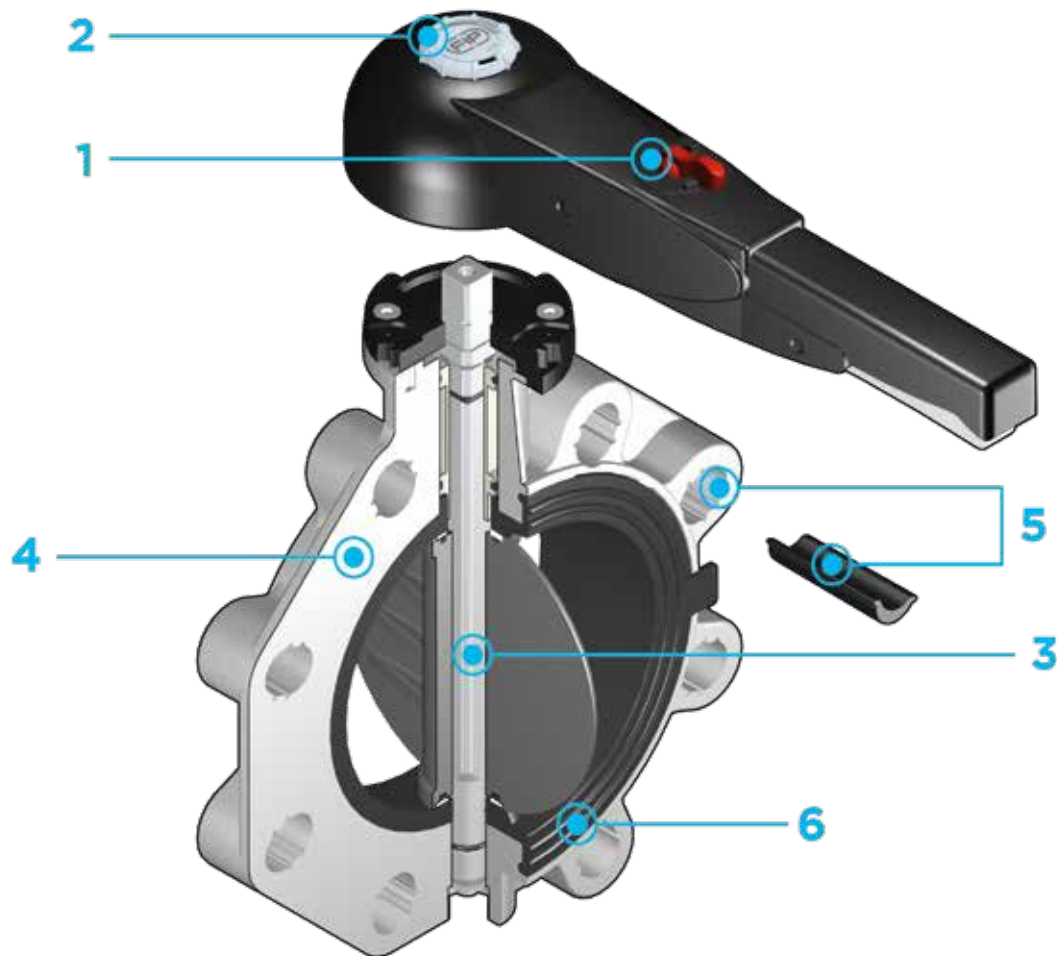

- 1 Ergonomic handle** in HIPVC equipped with **locking and unlocking device, release, quick operation and graduated adjustment** in 10 intermediate positions (DN 40÷200). The operating range, starting from the first few degrees of valve opening, also guarantees extremely low pressure drops.
- 2 Customisable Labelling System:** integrated module in the handle, made of a transparent protection plug and a customisable tag holder using the LSE set (available as an accessory). The **customisation** lets you **identify the**

- 3 STAINLESS steel square section stem** completely isolated from the fluid complying with standard ISO 5211:  
 DN 40÷65: 11 mm  
 DN 80÷100: 14 mm  
 DN 125÷150: 17 mm  
 DN 200: 22 mm  
 DN 250÷400: 27 mm
- 4 Body** in polypropylene based **compound reinforced with fibreglass (PP-GR) resistant to UV rays** and characterised by **high mechanical strength**.

- 5 Drilling pattern using oval slots** that allow coupling to flanges according to numerous international standards. The special **self-centring inserts in ABS** supplied for DN 40÷200 guarantee the **correct axial alignment** of the valve during installation. For DN 250÷400 valves, the drilling pattern for the selfcentring system is of the traditional type according to DIN and ANSI standards.
- 6 Interchangeable liner** with the dual function of forming a hydraulic seal and isolating the body from the fluid.

# TECHNICAL DATA

## PRESSURE VARIATION ACCORDING TO TEMPERATURE

For water and harmless fluids to which the material is classified as CHEMICALLY RESISTANT. In other cases, a reduction of the nominal PN pressure is required (25 years with safety factor).

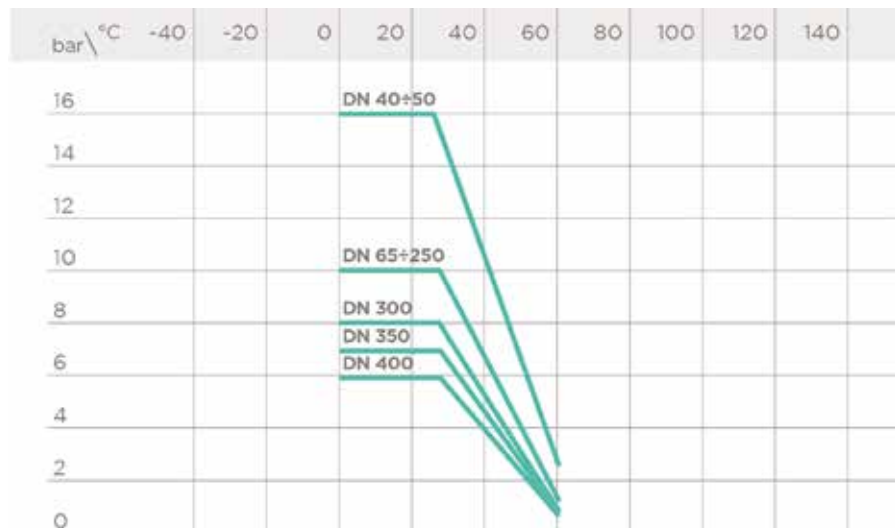

## PRESSURE DROP GRAPH

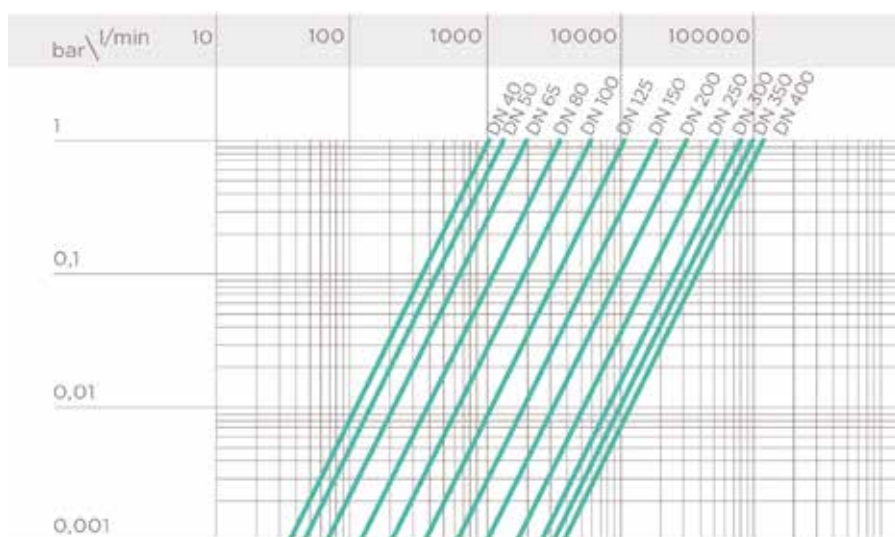

## K<sub>v</sub> 100 FLOW COEFFICIENT DN 40÷200

The K<sub>v</sub>100 flow coefficient is the Q flow rate of litres per minute of water at a temperature of 20°C that will generate Δp= 1 bar pressure drop at a certain valve position. The Kv100 values shown in the table are calculated with the valve completely open.

DN	40	50	65	80	100	125	150	200
Kv100 l/min	1000	1285	1700	3550	5900	9850	18700	30500

## K<sub>v</sub>100 FLOW COEFFICIENT DN 250÷400

The K<sub>v</sub>100 flow coefficient is the Q flow rate of litres per minute of water at a temperature of 20°C that will generate Δp= 1 bar pressure drop at a certain valve position. The Kv100 values shown in the table are calculated with the valve completely open.

DN	250	300	350	400
Kv100 l/min	53200	81600	94100	124900

## RELATIVE FLOW COEFFICIENT GRAPH

The relative flow coefficient is the flow rate through the valve as a function of the degree of valve opening.  
Horizontal axis: Percentage opening of the disk  
Vertical axis: Relative flow coefficient

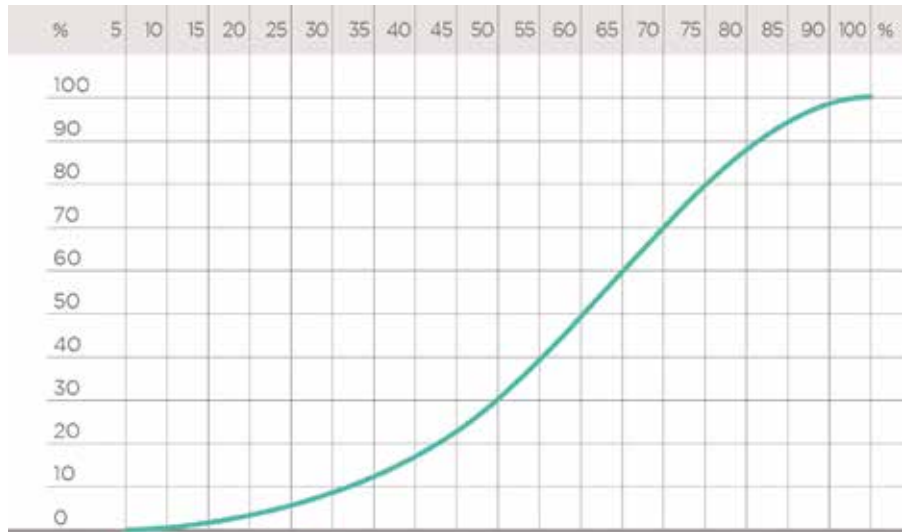

## OPERATING TORQUE AT MAXIMUM WORKING PRESSURE

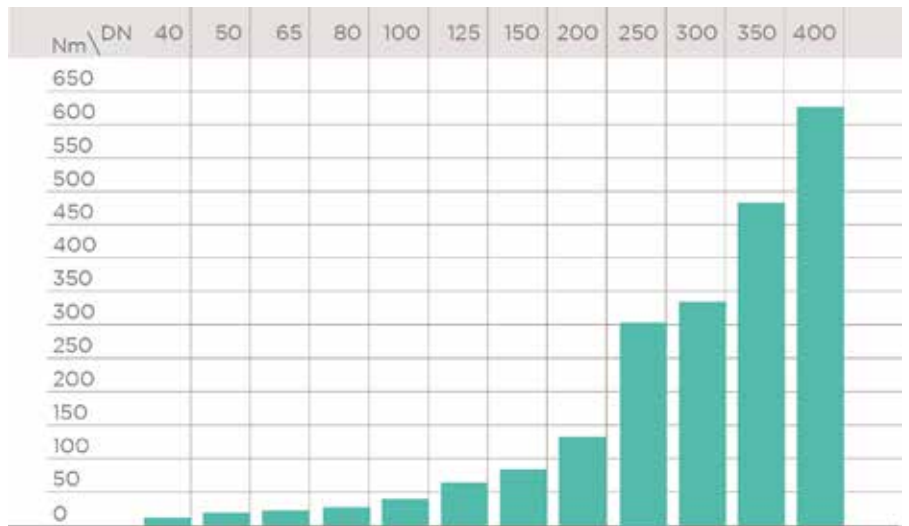

The information in this leaflet is provided in good faith. No liability will be accepted concerning technical data that is not directly covered by recognised international standards. FIP reserves the right to carry out any modification. Products must be installed and maintained by qualified personnel.

# DIMENSIONS

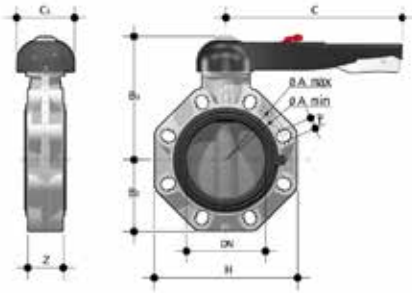

**FKOV/LM**  
Hand operated Butterfly valve

d	DN	PN	A min	A max	B <sub>2</sub>	B <sub>3</sub>	C	C <sub>1</sub>	H	U	Z	g	EPDM code
50 - 1 1/2"	40	16	99	109	60	137	175	100	132	4	33	1000	FKOVLM050E
63 - 2"	50	16	115	125,5	70	143	175	100	147	4	43	1180	FKOVLM063E
75 - 2 1/2"	65	10	128	144	80	164	175	110	165	4	46	1570	FKOVLM075E
90 - 3"	80	10	145	160	93	178	272	110	185	12	49	2020	FKOVLM090E
110 - 4"	100	10	165	190	107	192	272	110	211	8	56	2370	FKOVLM110E
*125 - 5"	125	10	204	215	120	212	330	110	240	8	56	3300	FKOVLM140E
140 - 5"	125	10	204	215	120	212	330	110	240	8	64	3300	FKOVLM140E
160 - 6"	150	10	230	242	134	225	330	110	268	8	70	4100	FKOVLM160E
**200 - 8"	200	10	280	298	161	272	420	122	323	8	71	7050	FKOVLM225E
225 - 8"	200	10	280	298	161	272	420	122	323	8	71	7050	FKOVLM225E

Note: for d75÷d225 NBR primary liner available

\* d125, FKOV d140 with special QPV FE-FK d125 for butterfly valve (QPV125FKE)

\*\* d200, FKOV d225 with special QPV FE-FK d200 for butterfly valve (QPV200FKE)

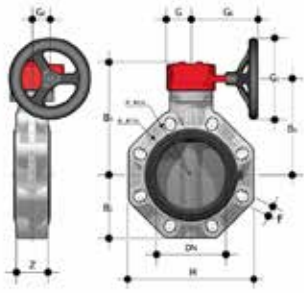

## FKOV/RM

Gearbox operated Butterfly valve

d	DN	PN	A min	A max	øA	B <sub>2</sub>	B <sub>5</sub>	B <sub>6</sub>	G	G <sub>1</sub>	G <sub>2</sub>	G <sub>3</sub>	H	U	Z	g	EPDM code
50	40	16	99	109	-	60	161	133	48	135	39	125	132	4	33	1974	FKOVRM050E
63	50	16	115	125,2	-	70	167	139	48	135	39	125	147	4	43	2154	FKOVRM063E
75 - 2 1/2"	65	10	128	144	-	80	174	146	48	135	39	125	165	4	46	2400	FKOVRM075E
90 - 3"	80	10	145	160	-	93	188	160	48	135	39	125	185	12	49	2800	FKOVRM090E
110 - 4"	100	10	165	190	-	107	202	174	48	135	39	125	211	8	56	3150	FKOVRM110E
*125 - 5"	125	10	204	215	-	120	222	194	48	144	39	200	240	8	64	4450	FKOVRM140E
140 - 5"	125	10	204	215	-	120	222	194	48	144	39	200	240	8	64	4450	FKOVRM140E
160 - 6"	150	10	230	242	-	134	235	207	48	144	39	200	268	8	70	5200	FKOVRM160E
**200 - 8"	200	10	280	298	-	161	287	256	65	204	60	200	323	8	71	9300	FKOVRM225E
225 - 8"	200	10	280	298	-	161	287	256	65	204	60	200	323	8	71	9300	FKOVRM225E
***250	250	10	-	-	350	210	317	281	88	236	76	250	405	12	114	18600	FKOVRM280E
***280	250	10	-	-	350	210	317	281	88	236	76	250	405	12	114	18600	FKOVRM280E
***315	300	8	-	-	400	245	374	338	88	236	76	250	475	12	114	25600	FKOVRM315E
355	350	7	-	-	460	280	438	390	88	361	80	300	530	16	129	34450	FKOVRM355E
400	400	6	-	-	515	306	438	390	88	361	80	300	594	16	169	42450	FKOVRM400E
****10"	250	10	-	-	362	210	317	281	88	236	76	250	405	12	114	18600	FKOAVRM810E
****12"	300	8	-	-	432	245	374	338	88	236	76	250	475	12	114	25600	FKOAVRM812E
14"	350	7	-	-	476	280	438	390	88	361	80	300	530	12	129	34450	FKOAVRM814E
16"	400	6	-	-	540	306	438	390	88	361	80	300	594	16	169	42450	FKOAVRM816E

Note:

FK suitable for flanged JIS K10 wafer installation is also available on request in the size 10" (DN250), 14" (DN350) and 16" (DN400).

\* d125, FKOV d140 with special QPV FE-FK d125 for butterfly valve (QPV125FKE)

\*\* d200, FKOV d225 with special QPV FE-FK d200 for butterfly valve (QPV200FKE)

\*\*\*\*ISO-DIN

\*\*\*\*ANSI B.16.5 cl.150

# ACCESSORIES

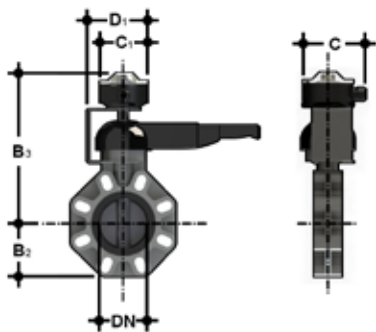

## LS Quick Kit

The Limit Switch Quick Kit allows the fast and secure installation of the FIP LSQT module to the FK/LM valves. The kit can be assembled on the valve even if already installed on the system. For technical data of the LSQT box see FIP actuated valves catalogue.

DN	B <sub>1</sub>	B <sub>2</sub>	C	C <sub>1</sub>	D <sub>1</sub>	Code
40	60	260,5	126,9	103	123,5	LSQKITFK5063
50	70	266,5	126,9	103	123,5	LSQKITFK5063
65	80	273,5	126,9	103	123,5	LSQKIT75160
80	93	287,5	126,9	103	123,5	LSQKIT75160
100	107	301,5	126,9	103	123,5	LSQKIT75160
125	120	321,5	126,9	103	123,5	LSQKIT75160
150	134	334,5	126,9	103	123,5	LSQKIT75160
200	161	385	126,9	103	129,8	LSQKIT225



## LSE

Customisation and label printing set for Easyfit handle made up of precut adhesive sheets and software for guided label creation.

DN	FE* - FK* code
40	LSE040
50	LSE040
65	LSE040
80	LSE040
100	LSE040
125	LSE040
150	LSE040
200	LSE040

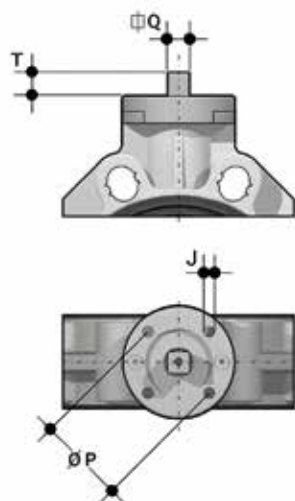

## Actuator mounting flange

The valve can be equipped with standard pneumatic or electric actuators and gearbox for heavy-duty operations, using a flange in PP-GR reproducing the drilling pattern provided for by standard ISO 5211.

DN	J	P	Ø	T	Q
40	7	50	F 05	12	11
50	7	50	F 05	12	11
65	7/9	50/70	F 05/F 07	12	11
80	9	70	F 07	16	14
100	9	70	F 07	16	14
125	9	70	F 07	19	17
150	9	70	F 07	19	17
200	11	102	F 10	24	22
200	11	102	F 10	24	22
250	11/13/17	102/125/140	F 10/ F 12/ F 14	29	27
300	11/13/17	102/125/140	F 10/ F 12/ F 14	29	27
350	14/18	125/140	F 12/ F 14	29	27
400	14/18	125/140	F 12/ F 14	29	27

# CUSTOMISATION

Fig. 1



Fig. 2



The FK valve is equipped with the customisable Labelling System.

This system lets you create special labels to insert in the handle. This makes it extremely easy to apply company logos, identification serial numbers or service indications such as, for example, the valve function in the system, the transported fluid, but also specific information for customer service, such as the customer name or installation date or location on the valves.

The specific LCE module is a standard supply and is made up of a rigid transparent water-resistant PVC plug (A-C) and white tag holder (B) made of the same material, one side of which bears the FIP logo (fig. 1).

The tag holder, inserted in the plug, can be removed and, once overturned, used for customisation by applying labels printed with the software supplied with the LSE set.

Proceed as follows to apply the label on the valve:

- 1) Remove the upper part of the transparent plug (A) rotating it counter-clockwise as indicated by the word "Open" on the plug and remove it.
- 2) Extract the tag holder from its housing on the lower part of the plug (C).
- 3) Apply the adhesive label on the holder (B) to align the profiles matching the tab position.
- 4) Reinsert the tag holder in its housing at the bottom of the plug.
- 5) Reposition the top of the plug in the housing rotating it clockwise; this way the label is protected against the elements.

# COMPONENTS

## EXPLODED VIEW DN 40÷65

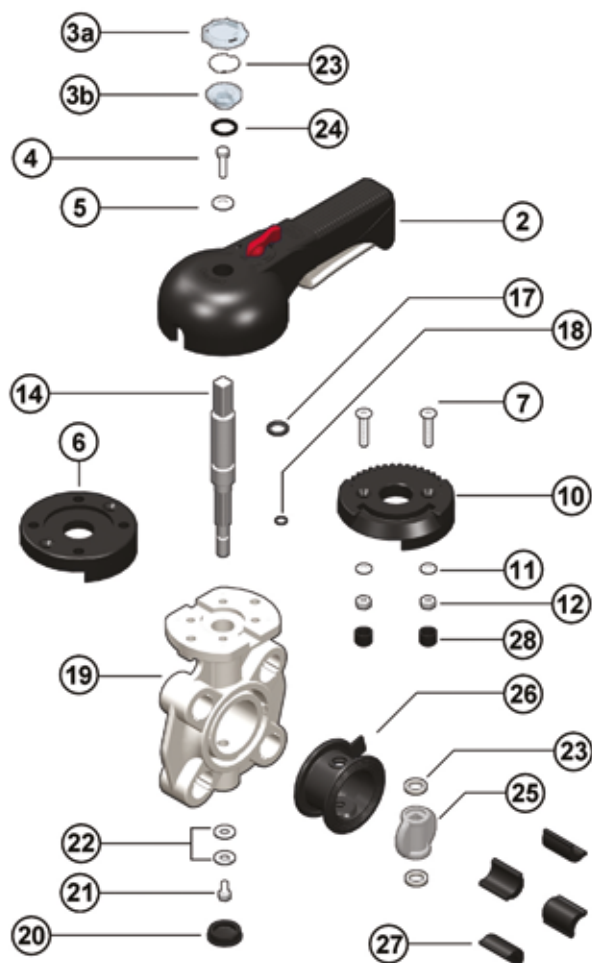

- |             |                                       |           |                                |           |                               |
|-------------|---------------------------------------|-----------|--------------------------------|-----------|-------------------------------|
| <b>1</b>    | Position indicator (PA - 1)           | <b>8</b>  | Tag holder (PVC-U - 1)         | <b>20</b> | Protection plug (PE - 1)      |
| <b>2</b>    | Handle (HIPVC - 1)                    | <b>9</b>  | O-Ring (NBR - 1)               | <b>21</b> | Screw (STAINLESS steel - 1)   |
| <b>3a/b</b> | Transparent protection plug (PVC - 1) | <b>10</b> | Plate (PP-GR - 1)              | <b>22</b> | Washer (STAINLESS steel - 2)  |
| <b>4</b>    | Fastening screw (STAINLESS steel - 1) | <b>11</b> | Washer (STAINLESS steel - 2)   | <b>23</b> | Anti-friction ring (PTFE - 2) |
| <b>5</b>    | Washer (STAINLESS steel - 1)          | <b>12</b> | Nut (STAINLESS steel - 2)      | <b>25</b> | Disk (PVC-U- 1)               |
| <b>6</b>    | Flange (PP-GR - 1)                    | <b>14</b> | Stem (STAINLESS steel 316 - 1) | <b>26</b> | Liner (EPDM o FKM - 1)        |
| <b>7</b>    | Screw (STAINLESS steel - 2)           | <b>17</b> | Stem O-Ring (FKM - 1)          | <b>27</b> | Inserts (ABS - 4-8)           |
|             |                                       | <b>18</b> | Stem O-Ring (FKM - 1)          | <b>28</b> | Plug (PE - 2)                 |
|             |                                       | <b>19</b> | Body (PP-GR - 1)               |           |                               |

The component material and quantity supplied are indicated in the parentheses.



## EXPLODED VIEW DN 80÷200

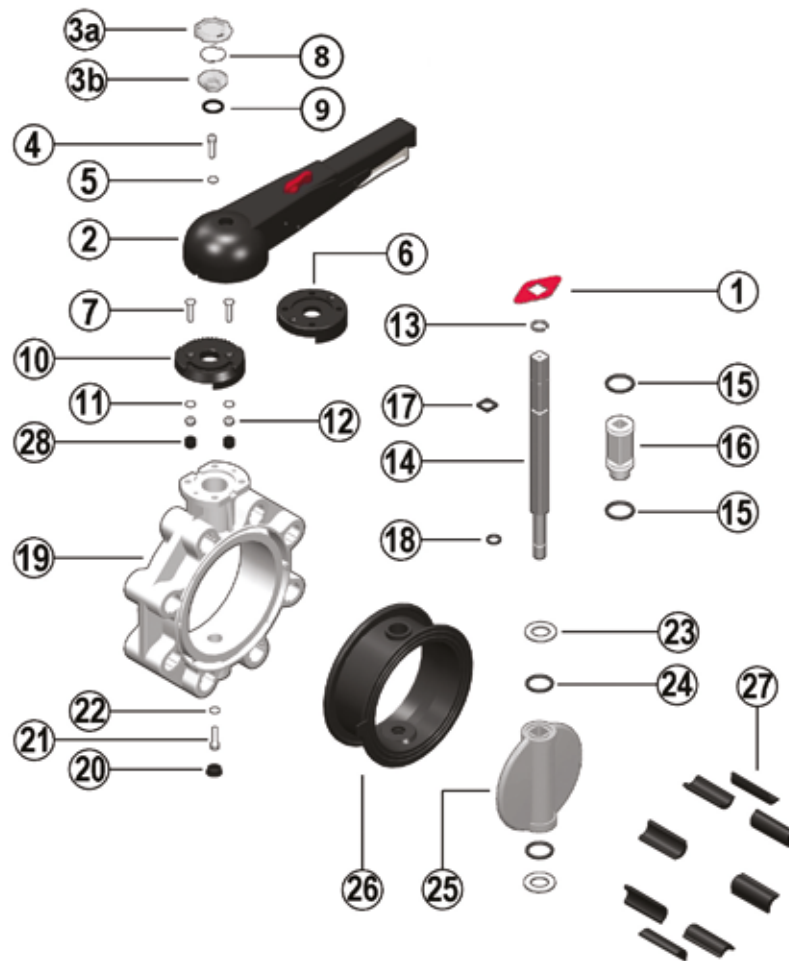

- |             |                                       |           |                                   |           |                               |
|-------------|---------------------------------------|-----------|-----------------------------------|-----------|-------------------------------|
| <b>1</b>    | Position indicator (PA - 1)           | <b>9</b>  | O-Ring (NBR - 1)                  | <b>19</b> | Body (PP-GR - 1)              |
| <b>2</b>    | Handle (HIPVC - 1)                    | <b>10</b> | Plate (PP-GR - 1)                 | <b>20</b> | Protection plug (PE - 1)      |
| <b>3a/b</b> | Transparent protection plug (PVC - 1) | <b>11</b> | Washer (STAINLESS steel - 2)      | <b>21</b> | Screw (STAINLESS steel - 1)   |
| <b>4</b>    | Fastening screw (STAINLESS steel - 1) | <b>12</b> | Nut (STAINLESS steel - 2)         | <b>22</b> | Washer (STAINLESS steel - 1)  |
| <b>5</b>    | Washer (STAINLESS steel - 1)          | <b>13</b> | Seeger ring (STAINLESS steel - 2) | <b>23</b> | Anti-friction ring (PTFE - 2) |
| <b>6</b>    | Flange (PP-GR - 1)                    | <b>14</b> | Stem (STAINLESS steel 316 - 1)    | <b>24</b> | Disk O-Ring (FKM - 2)         |
| <b>7</b>    | Screw (STAINLESS steel - 2)           | <b>15</b> | Bush O-Ring (FKM - 2)             | <b>25</b> | Disk (PVC-U - 1)              |
| <b>8</b>    | Tag holder (PVC-U - 1)                | <b>16</b> | Bush (Nylon - 1)                  | <b>26</b> | Liner (EPDM o FKM - 1)        |
|             |                                       | <b>17</b> | Stem O-Ring (FKM - 1)             | <b>27</b> | Inserts (ABS - 4-8)           |
|             |                                       | <b>18</b> | Stem O-Ring (FKM - 1)             | <b>28</b> | Plug (PE - 2)                 |

The component material and quantity supplied are indicated in the parentheses.

## EXPLODED VIEW DN 250÷300

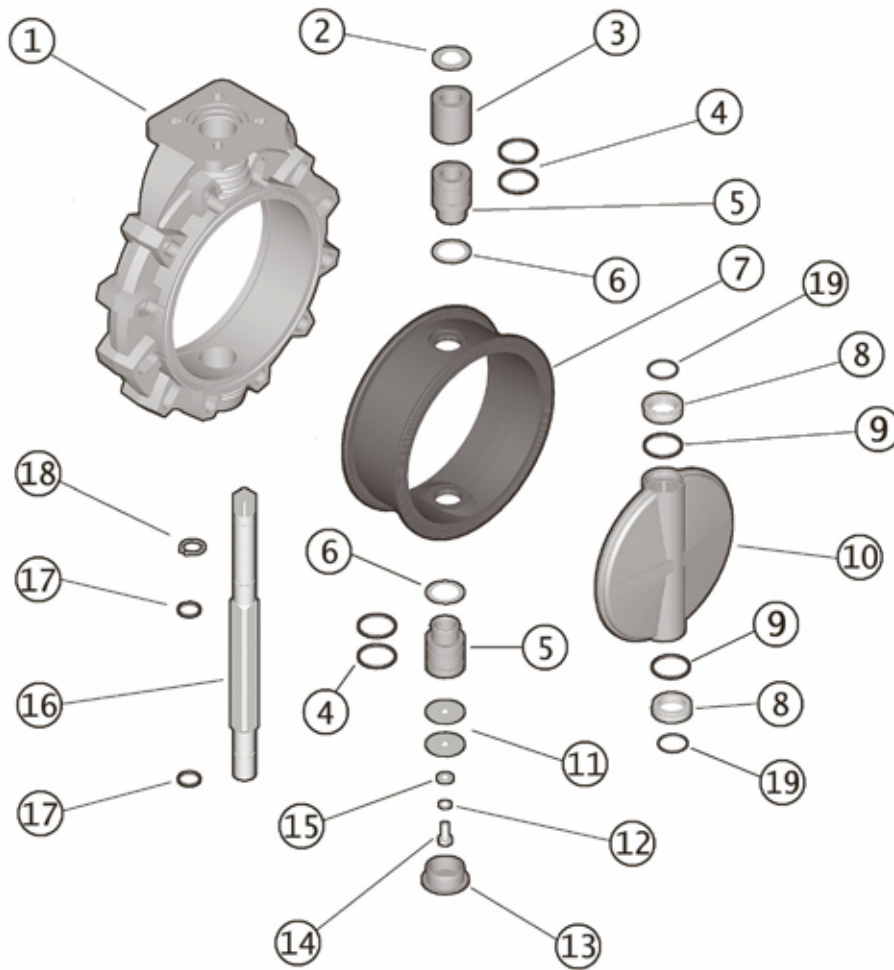

- |          |                              |           |                               |           |                                   |
|----------|------------------------------|-----------|-------------------------------|-----------|-----------------------------------|
| <b>1</b> | Body (PP-GR - 1)             | <b>8</b>  | Anti-friction ring (PTFE - 2) | <b>15</b> | Washer (STAINLESS steel - 1)      |
| <b>2</b> | Washer (STAINLESS steel - 1) | <b>9</b>  | Disk O-Ring (FKM - 2)         | <b>16</b> | Stem (STAINLESS steel 316 - 1)    |
| <b>3</b> | Bush (PP - 1)                | <b>10</b> | Disk (PVC-U - 1)              | <b>17</b> | Stem O-Ring (FKM - 2)             |
| <b>4</b> | Bush O-Ring (FKM - 4)        | <b>11</b> | Washer (STAINLESS steel - 2)  | <b>18</b> | Seeger ring (STAINLESS steel - 1) |
| <b>5</b> | Bush (PP - 2)                | <b>12</b> | Washer (STAINLESS steel - 1)  | <b>19</b> | O-Ring (FKM - 2)                  |
| <b>6</b> | Washer (PTFE - 2)            | <b>13</b> | Protection plug (PE - 1)      |           |                                   |
| <b>7</b> | Liner (EPDM o FKM - 1)       | <b>14</b> | Screw (STAINLESS steel - 1)   |           |                                   |

The component material and quantity supplied are indicated in the parentheses.

## EXPLODED VIEW DN 350÷400

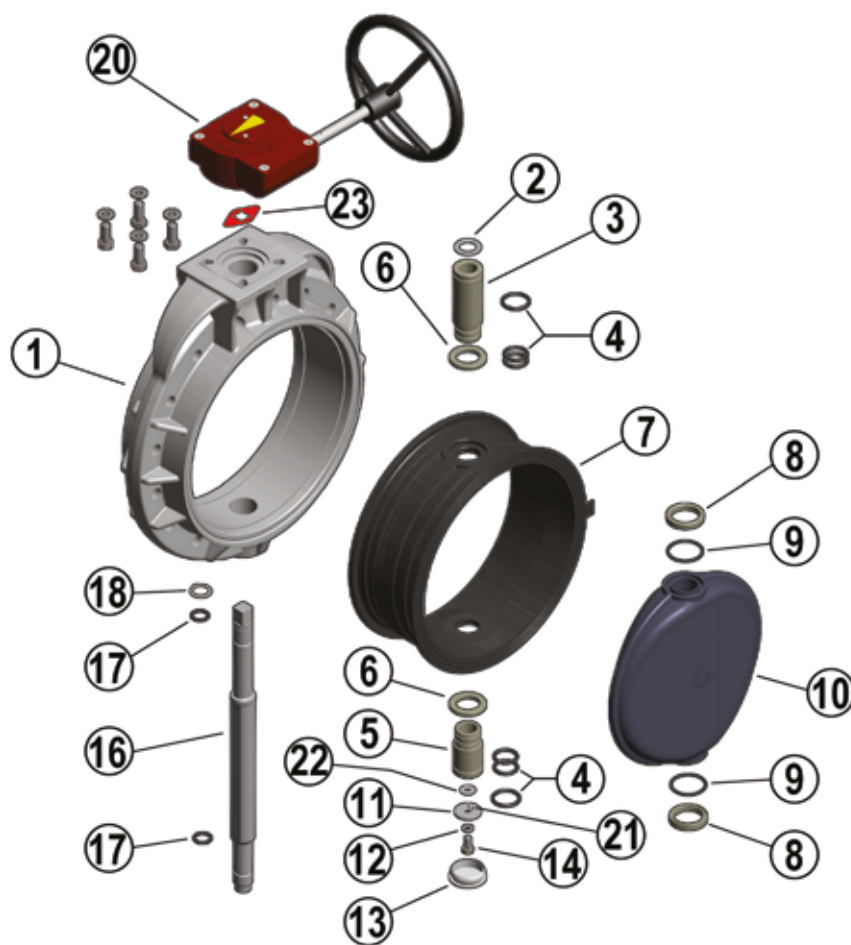

- |          |                               |           |                               |           |                                   |
|----------|-------------------------------|-----------|-------------------------------|-----------|-----------------------------------|
| <b>1</b> | Body (PP-GR - 1)              | <b>8</b>  | Anti-friction ring (PTFE - 2) | <b>16</b> | Stem (STAINLESS steel 316 - 1)    |
| <b>2</b> | Washer (STAINLESS steel - 1)  | <b>9</b>  | Disk O-Ring (EPDM or FKM - 2) | <b>17</b> | Stem O-Ring (EPDM or FKM - 2)     |
| <b>3</b> | Bush (PP-H - 1)               | <b>10</b> | Disk (PVC-U - 1)              | <b>18</b> | Seeger ring (STAINLESS steel - 1) |
| <b>4</b> | Bush O-Ring (EPDM or FKM - 6) | <b>11</b> | Washer (STAINLESS steel - 1)  | <b>20</b> | Gearbox (Al, Steel - 1)           |
| <b>5</b> | Bush (PP-H - 1)               | <b>12</b> | Washer (STAINLESS steel - 1)  | <b>21</b> | Pin (STAINLESS steel - 2)         |
| <b>6</b> | Washer (PP-H - 2)             | <b>13</b> | Protection plug (PE - 1)      | <b>22</b> | Washer (STAINLESS steel - 1)      |
| <b>7</b> | Liner (EPDM o FKM - 1)        | <b>14</b> | Screw (STAINLESS steel - 1)   | <b>23</b> | Position indicator (PA - 1)       |

The component material and quantity supplied are indicated in the parentheses.

## DISASSEMBLY

### DN 40÷200

- 1) Remove the LCE module consisting of the rigid transparent PVC plug (3a-3b) and white tag holder (8) and remove screw (2) and washer (3) (fig.3).
- 2) Remove the handle (2).
- 3) Remove the screws (7) and plate (10) from the body (19).
- 4) Remove the protection plug (20) and screw (21) with the washer (22).
- 5) Extract the stem (14) and disk (25).
- 6) Remove the anti-friction rings (23) and (DN 65÷200 only) O-Rings (24).
- 7) Remove the liner (26) from the body (19).
- 8) Remove the Seeger ring (13) and (DN 65÷200 only) guide bush (16).
- 9) Remove (DN 65÷200 only) the O-Rings (15) and (17, 18).

### DN 250÷300

- 1) Remove the protection plug (13) and screw (14) with the washers (11-15).
- 2) Extract the stem (16) and disk (10).
- 3) Remove the seal (7) from the body (1).
- 4) Remove the Seeger ring (18) and guide bushes (5-3) with washer (2).
- 5) Extract the lower bush (5).
- 6) Remove O-Rings (4) and (17).

### DN 350÷400

- 1) Remove the position indicator (23) from the stem (16).
- 2) Remove the protection plug (13) from the body (1).
- 3) Remove the screw (14) and the washers (11) and (22).
- 4) Extract the stem unit (16) from the disk.
- 5) Extract the lower bush unit (5) from the lower part of the body (1).
- 6) Remove the disk unit (10) from the body (1).

## ASSEMBLY

### DN 40÷200

- 1) Place the liner (26) on the body (19).
- 2) Insert the O-Rings (17) and (18) on the stem (14).
- 3) Insert the O-Rings (15) on the guide bush (16) and the bush on the stem. Lock the bush using the Seeger ring (13).
- 4) Position the O-Rings (24) and then the anti-friction rings (23) on the disk (25) and the disk inside the body, after having lubricated the liner (26).
- 5) Insert the through stem (14) in the body (19) and disk (25).
- 6) Tighten screw (21) with washer (22) and insert the protection plug (20).
- 7) Position the plate (10) on the body (19) and tighten screws (7).
- 8) Position the handle (2) on the stem (14).
- 9) Tighten screw (4) with washer (5) and replace the LCE module consisting of the rigid transparent PVC plug (3a-3b) and white tag holder (8).

### DN 250÷300

- 1) Place the liner (7) on the body (1).
- 2) Insert the O-Rings (4) and washer (6) on bushes (5).
- 3) Insert the O-Rings (17) on the stem (16); insert the upper bush (5), bush (3), washer (2) on the stem and fix them with Seeger ring (18).
- 4) Insert the seals (19-9) on the antifriction rings (8).
- 5) Position the washers (8) in the housings on the disk (10), and the disk inside the body (1) after having lubricated the liner (7).
- 6) Insert the through stem (16) in the body and disk.
- 7) Position the lower bush (5) from below.
- 8) Tighten screws (14) with washers (11-15) and insert the protection plug (13).

## DN 350÷400

- 1) Insert the lower bush (5) complete with O-rings (4) on the body (1), subsequently inserting the gland packing washer (6) between the bush and the body.
- 2) Insert the second gland packing washer (6) on the liner (7) and fit these inside the body (1).
- 3) Insert the O-rings (9) and anti-friction rings (8) on the disks (10).
- 4) Lubricate the disk (10) and insert it into the liner (7).
- 5) Insert the upper bush complete with O-rings (3 + 4) on the stem (16) joined to the O-rings (17); insert the washer (2) above the upper bush (3) and insert Seeger ring (18) in the appropriate housing on the stem (16). Insert this unit in the body's upper hole (1).
- 6) Overlap washer (22) on washer (11) equipped with pins (21), and insert this unit on the lower part of the stem (16), fastening it with screw (14) and locking washer (12).
- 7) Insert the protection plug (13) on the body (1).
- 8) Insert the position indicator (23) on the upper part of the stem (16).



**Note:** during assembly operations, it is advisable to lubricate the rubber seals. Mineral oils are not recommended for this task as they react aggressively with EPDM rubber.

Fig. 3



# INSTALLATION

## JOINTS

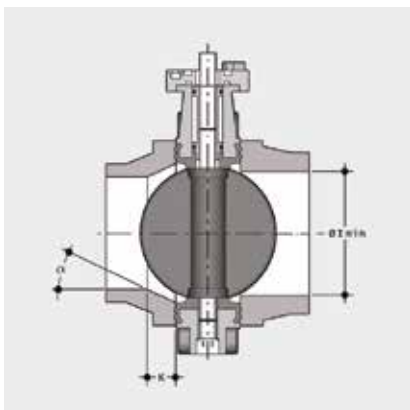

Before proceeding with the installation of the stubs, check that the bore of the fittings has sufficient clearance to allow the valve disk to open correctly. Also check the maximum coupling distance for the liner. Before proceeding with the installation of the FK valve, check that the bore of the stub allows the correct opening of the disk.

DN	l min.
40	25
50	28
65	47
80	64
100	84
125	108
150	134
200	187
250	225
300	280
350	324
400	362

## PVC-U STUBS

To install on PVC-U collars, check the valve-collar-flange couplings in the following table.

d	DN	50	63	75	90	110	125	140	160	180	200	225	250	280	315	355	400
		40	50	65	80	100	100	125	150	150	200	200	250	250	300	350	400
50	40	■															
63	50		■														
75	65			■													
90	80				■												
110	100					■											
140	125						■	■									
160	150								■	■							
225	200										■	■					
280	250												■	■			
315	300														■		
355	350															■	
400	400																■

Stub with female end for solvent welding according to EN ISO 1452  
 \* With special collar d125 DN125 for FK d140 DN125 and flange d140 DN125  
 \*\* With special collar d200 DN200 for FK d225 DN200 and flange d225 DN200

## PP-PE STUBS

For the installation of PP-PE stubs, for butt welding a short spigot or electrofusion/butt welding a long spigot, check the valve-stub-flange couplings and the K - a chamfer dimensions where necessary according to the different SDR's in the following table.

	d	50	63	75	90	110	125	140	160	180	200	225	250	280	315	355	400	
	DN	40	50	65	80	100	100	125	150	150	200	200	250	250	300	350	400	
FK	50	40																
	63	50																
	75	65																
	90	80																
	110	100																
	140	125																
	160	150																
	225	200																
	280	250																
	315	300																
	355	350																
	400	400																
	SDR	17/17,6										k=26,5 a=20°		k=15,7 a=25°		k=13,3 a=25°	k=45 a=25°	k=55 a=25°
11											k=35 a=20°	k=35 a=25°	k=40 a=15°	k=32,5 a=25°	k=35 a=25°	k=34,5 a=25°	k=55 a=25°	k=80 a=25°
7,4					k=10 a=35°	k=15 a=35°		k=20 a=30°	k=35 a=20°	k=15 a=35°	k=40 a=20°	k=35 a=30°	k=55 a=30°	k=35 a=30°	k=65 a=30°			
33																k=17 a=30°	k=25 a=35°	

Short/long spigot stubs according to EN ISO 15494

## POSITIONING THE INSERTS

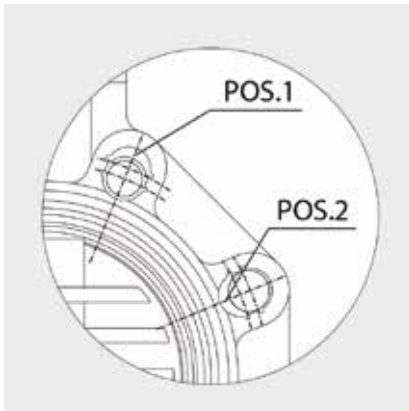

Place the inserts in the holes according to the positions indicated in the table, from the side corresponding to the letters D and DN in order to facilitate the insertion of the stud-bolts and the coupling with the flanges (DN 40 ÷ 200). The self-centring inserts must be inserted in the guides in the slots in the valve body on the side with the writing, with the writing facing upwards, and positioned according to the type of flange drilling, as indicated in the following table:

DN	EN 1092-1 PN6	PN10/16 EN 1092-1, EN ISO 15493, EN ISO 1452	BS 10 table A-D-E Spec D-E	ANSI B16.5 cl.150*	JIS B 2220 K5	JIS 2211 K10**
40	Pos. 1	Pos. 2	Pos. 1	Pos. 1	Pos. 1	-
50	Pos. 1	Pos. 2	Pos. 1	-	N/A	-
65	Pos. 1	Pos. 2	Pos. 1	Pos. 2	Pos. 1	Pos. 2
80	Pos. 1	Pos. 2	Pos. 1	Pos. 2	Pos. 1	Pos. 1
100	Pos. 1	Pos. 2	Pos. 1	Pos. 2	Pos. 1	Pos. 1
125	Pos. 1	Pos. 2	Pos. 1	Pos. 2	Pos. 1	-
150	Pos. 1	Pos. 2	Pos. 1	Pos. 2	Pos. 1	Pos. 2
200	Pos. 1	PN 10 Pos. 2	Pos. 2	Pos. 2	Pos. 1	N/A

\* DN 50 without inserts

\*\* DN 40, 50, 125 without inserts

## JIS FLANGED OPTIONS

FK suitable for flanged JIS K10 wafer installation is also available on request in the size 10" (DN250), 14" (DN350) and 16" (DN400) and in JIS K5 in the size of 10" (DN250) and 12" (DN300)

## POSITIONING THE VALVE

Position the valve between two flanged stubs, taking care to respect the installation tolerances Z. It is advisable to always install the valve with the disk partially closed (it must not exit the body) and avoid any misalignment of the flanges, as this would cause

leaks. Where possible comply with the following requirements:

- Conveying dirty fluids: position the valve with the stem inclined at an angle of 45° to the pipe support plane.
- Conveying fluids with sediment: position the valve with the stem parallel to the pipe support plane.
- Conveying clean fluids: position the valve with the stem perpendicular to the pipe support plane.



## TIGHTENING THE STUD-BOLTS

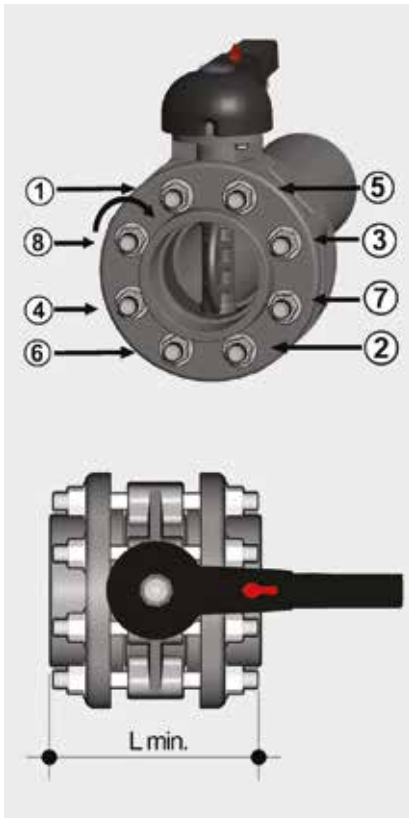

Before tightening the stud-bolts, it is advisable to open the disk in order to prevent damage to the seal. Tighten the stud-bolts in a uniform manner, in the order indicated in the figure, to the nominal operating torque value indicated in the table. The stud-bolts do not need to be excessively tightened in order to produce a perfect hydraulic seal. Overtightening could adversely affect the operating torque of the valve.

DN	L min.	*Nm
40	M16 x 150	9
50	M16 x 150	12
65	M16 x 170	15
80	M16 x 180	18
100	M16 x 180	20
125	M16 x 210	35
150	M20 x 240	40
200	M20 x 260	55
250	M20 x 310	70
300	M20 x 340	70
350	M20 x 360	75
400	M24 x 420	75

\* Tightening torques for nuts and bolts on couplings with backing rings.

Values required to obtain the hydraulic test seal (1.5xPN at 20°C) (new or lubricated nuts and bolts)

## HANDLE LOCK



Thanks to the multifunctional handle and the red manoeuvre button on the lever, you can perform a 0°-90° operation and a graduated operation by means of the 10 intermediate positions and a stop lock: the handle can be locked in each of the 10 positions by simply pressing the Free-lock button. A lock can also be installed on the handle to protect the system against tampering. The valve is two-way and can be installed in any position. It can also be installed at end line or tank.

# DK DN 15÷65

The DK DIALOCK® diaphragm valve is particularly suitable for shutting off and regulating abrasive or dirty fluids. The new internal geometry of the body increases flow coefficient, reduce pressure drop and allows a sensitive and precise adjustment along the entire stroke of the shutter. The DK is extremely compact and very light. The innovative handwheel is equipped with a patented immediate and ergonomic operating locking device that allows it to be adjusted and locked in any position.

**Dialock**®

## DIALOCK® 2-WAY DIAPHRAGM VALVE

- **Optimised fluid dynamic design:** maximum output flow rate thanks to the optimised efficiency of the fluid dynamics that characterise the new internal geometry of the body
- **Internal components in metal, totally isolated from the fluid** and external environment
- **Modularity of the range:** only 2 handwheel and 4 diaphragm and bonnet sizes for 7 different valve sizes
- Non-rising handwheel that stays at the same height during rotation, equipped with a graduated optical indicator protected by a transparent PVC cap with seal O-Ring
- Bonnet fastening screws in stainless steel protected against the external environment by PE plugs. Absence of metal parts exposed to the external environment to prevent any risk of corrosion.
- **CDSA** (Circular Diaphragm Sealing Angle) system that, thanks to the uniform distribution of shutter pressure on the diaphragm seal, offers the following advantages:
  - reduction in the tightening torque of the screws fixing the actuator to the valve body
  - reduced mechanical stress on all valve components (actuator, body and diaphragm)
  - easy to clean valve interior
  - low risk of the accumulation of deposits, contamination or damage to the diaphragm due to crystallisation
  - operating torque reduction

Technical specifications	
<b>Construction</b>	Diaphragm valve with maximized flow rate and DIALOCK® lockable handwheel
<b>Size range</b>	DN 15 ÷ 65
<b>Nominal pressure</b>	PN 10 with water at 20° C
<b>Temperature range</b>	0 °C ÷ 60 °C
<b>Coupling standards</b>	<b>Flanging system:</b> ISO 7005-1, EN ISO 1452, EN ISO 15493, EN 558-1, EN 1092-1, ANSI B.16.5 cl. 150, JIS B 2220.
<b>Reference standards</b>	<b>Construction criteria:</b> EN ISO 16138, EN ISO 1452, EN ISO 15493
	<b>Test methods and requirements:</b> ISO 9393
	<b>Installation criteria:</b> DVS 2204, DVS 2221, UNI 11242
<b>Valve material</b>	<b>Body:</b> PVC-U <b>Bonnet and handwheel:</b> PP-GR <b>Position indicator cap:</b> PVC
<b>Seal material</b>	EPDM
<b>Control options</b>	Manual control; pneumatic actuator

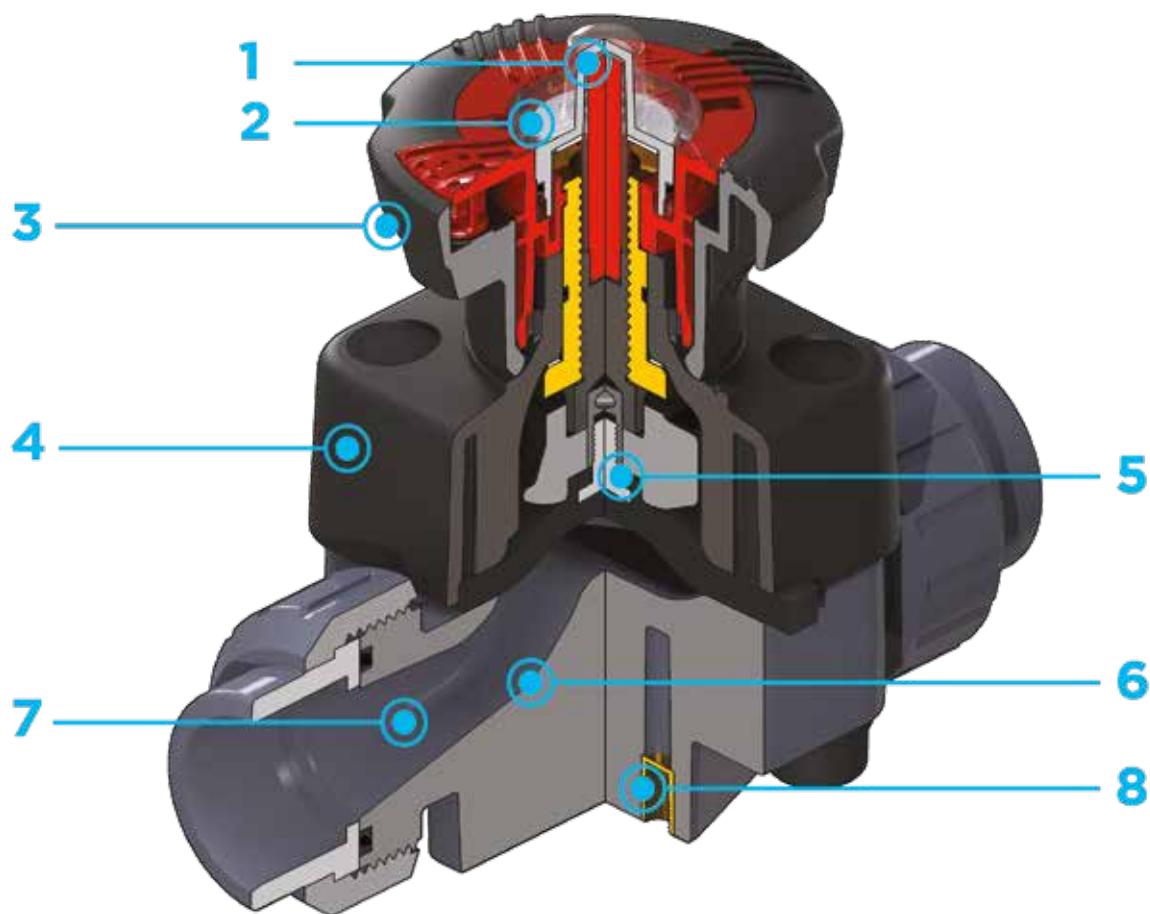

**1** **High visibility graduated optical position indicator** protected by a transparent cap with seal O-Ring

**2** **Customisation plate:** the customisation lets you identify the valve on the system according to specific needs

**3** **DIALOCK® SYSTEM:** innovative handwheel with a patented immediate and ergonomic operating locking device that allows it **to be adjusted and locked in over 300 positions**

**4** **Handwheel and bonnet in high mechanical strength and chemically resistant PP-GR,** providing full protection by isolating all internal metal parts from contact with external agents

**5** **Floating pin connection** between the control screw and diaphragm to prevent concentrated loads, improve the seal and extend its lifetime

**6** **New design of valve body interior: substantially increased flow coefficient** and reduced pressure drop. The degree of efficiency

reached has also **enabled the size and weight of the valve to be reduced**

**7** **Adjustment linearity:** the internal profiles of the valve also greatly improve its characteristic curve, resulting in **extremely sensitive and precise adjustment** along the entire stroke of the shutter

**8** **Valve anchoring bracket integrated in the body,** with threaded metal inserts allowing **simple panel or wall mounting** using the PMDK mounting plate (supplied as an accessory)

# TECHNICAL DATA

## PRESSURE VARIATION ACCORDING TO TEMPERATURE

For water and non-hazardous fluids with regard to which the material is classified as CHEMICALLY RESISTANT. In other cases, a reduction of the nominal pressure PN is required (25 years with safety factor).



## PRESSURE DROP GRAPH

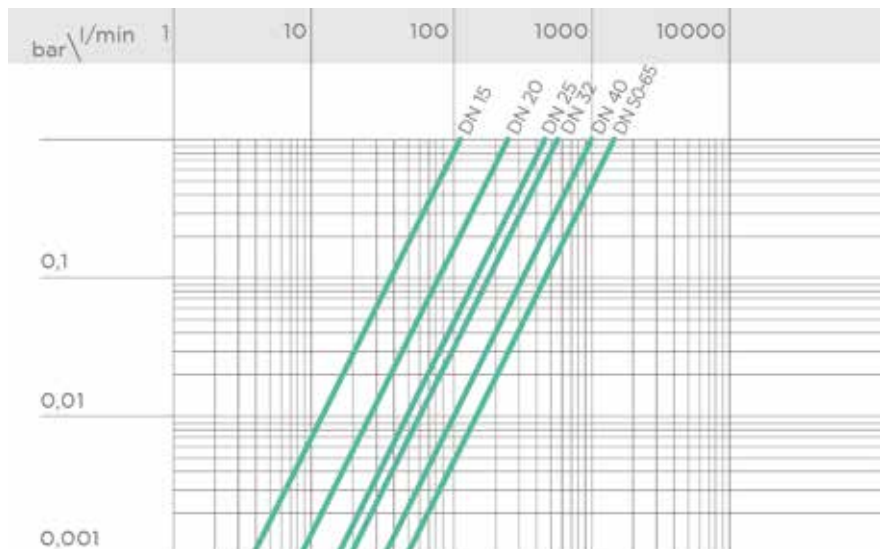

## K<sub>v</sub>100 FLOW COEFFICIENT

The K<sub>v</sub>100 flow coefficient is the Q flow rate of litres per minute of water at a temperature of 20°C that will generate Δp= 1 bar pressure drop at a certain valve position. The Kv100 values shown in the table are calculated with the valve completely open.

DN	15	20	25	32	40	50	65
Kv100 l/min	112	261	445	550	1087	1648	1600

## RELATIVE FLOW COEFFICIENT GRAPH

The relative flow coefficient is the flow rate through the valve as a function of the degree of valve opening.

Horizontal axis: Percentage opening of the valve

Vertical axis: Relative flow coefficient

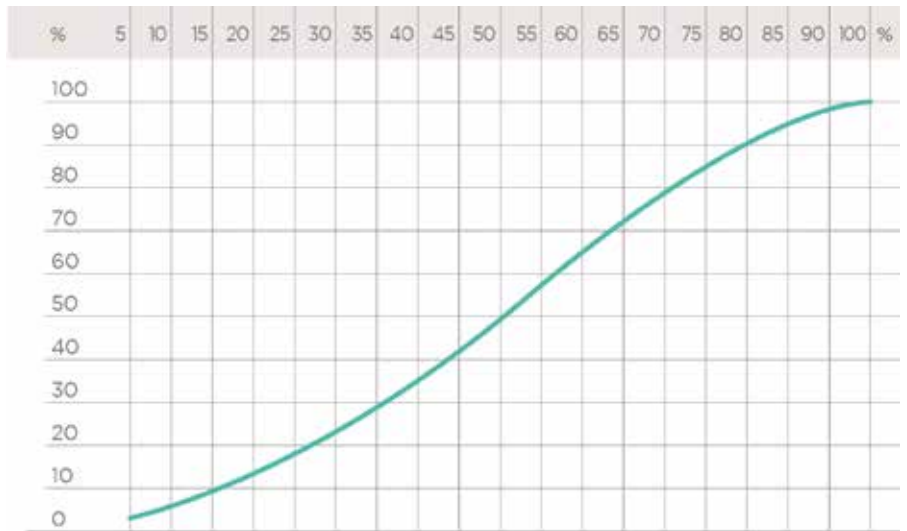

# DIMENSIONS

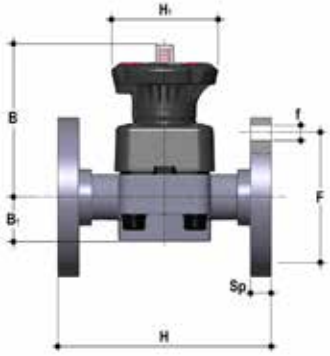

## DKOV

DIALOCK® diaphragm valve with flanged monolithic body, drilled PN10/16. Face to face according to EN 558-1

d	DN	PN	B	B <sub>1</sub>	F	f	H	H <sub>1</sub>	Sp	U	g	EPDM code
20	15	10	102	25	65	14	130	80	4	13.5	925	DKOV020E
25	20	10	105	30	75	14	150	80	4	13.5	990	DKOV025E
32	25	10	114	33	85	14	160	80	4	13.5	1054	DKOV032E
40	32	10	119	30	100	18	180	80	4	14	1272	DKOV040E
50	40	10	149	35	110	18	200	120	4	16	2164	DKOV050E
63	50	10	172	46	125	18	230	120	4	16	3009	DKOV063E
75	65	10	172	46	145	18	290	120	4	21	3610	DKOV075E

DKLOV version available on request

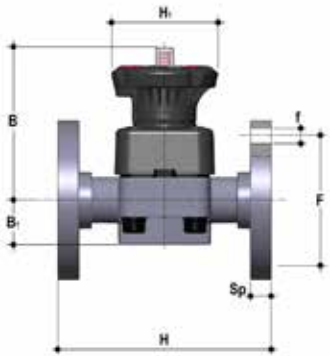

## DKOAV

DIALOCK® diaphragm valve with flanged monolithic body, drilled ANSI B16.5 cl. 150 #FF

d	DN	PN	B	B <sub>1</sub>	F	f	H	H <sub>1</sub>	Sp	U	g	EPDM code
1/2"	15	10	102	25	60.3	14	108	80	13,5	4	925	DKOAV012E
3/4"	20	10	105	30	70	15.7	120	80	13,5	4	990	DKOAV034E
1"	25	10	114	33	80	15.7	131	80	13,5	4	1054	DKOAV100E
1" 1/4	32	10	119	30	89	15.7	162	80	14	4	1272	DKOAV114E
1" 1/2	40	10	149	35	99	15.7	180	120	16	4	2164	DKOAV112E
2"	50	10	172	46	121	19	210	120	16	4	3009	DKOAV200E
2" 1/2	65	10	172	46	140	19	250	120	21	4	3610	DKOAV212E

DKLOAV version available on request  
For installation prior to october 2017 please contact Fip Technical Support

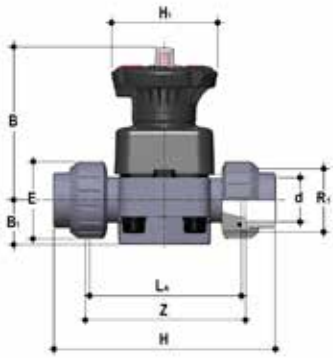

## DKUIV

DIALOCK® diaphragm valve with female union ends for solvent welding, metric series

d	DN	PN	B	B <sub>1</sub>	E	H	H <sub>1</sub>	L <sub>1</sub>	R <sub>1</sub>	Z	g	EPDM code
20	15	10	102	25	41	129	80	90	1"	100	500	DKUIV020E
25	20	10	105	30	50	154	80	108	1 1/4"	116	562	DKUIV025E
32	25	10	114	33	58	168	80	116	1 1/2"	124	790	DKUIV032E
40	32	10	119	30	72	192	80	134	2"	140	916	DKUIV040E
50	40	10	149	35	79	222	120	154	2 1/4"	160	1768	DKUIV050E
63	50	10	172	46	98	266	120	184	2 3/4"	190	2668	DKUIV063E

To be used with Q/BBE-L union ends (see accessories)

# ACCESSORIES

## Q/BBE-L

Long spigot PE100 end connectors for electrofusion or butt welding

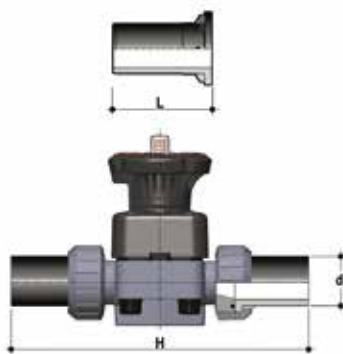

d	DN	PN	L	H	SDR	Code
20	15	16	95	280	11	QBBEL11020
25	20	16	95	298	11	QBBEL11025
32	25	16	95	306	11	QBBEL11032
40	32	16	95	324	11	QBBEL11040
50	40	16	95	344	11	QBBEL11050
63	50	16	95	374	11	QBBEL11063

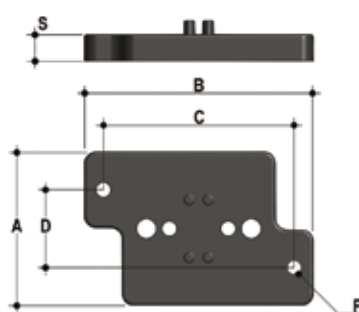

## PMDK

Wall mounting plate

d	DN	A	B	C	D	F	S	Code
20	15	65	97	81	33	5,5	11	PMDK1
25	20	65	97	81	33	5,5	11	PMDK1
32	25	65	97	81	33	5,5	11	PMDK1
40	32	65	97	81	33	5,5	11	PMDK2
50	40	65	144	130	33	6,5	11	PMDK2
63	50	65	144	130	33	6,5	11	PMDK2
75	65	65	144	130	33	6,5	11	PMDK2



# COMPONENTS

## EXPLODED VIEW

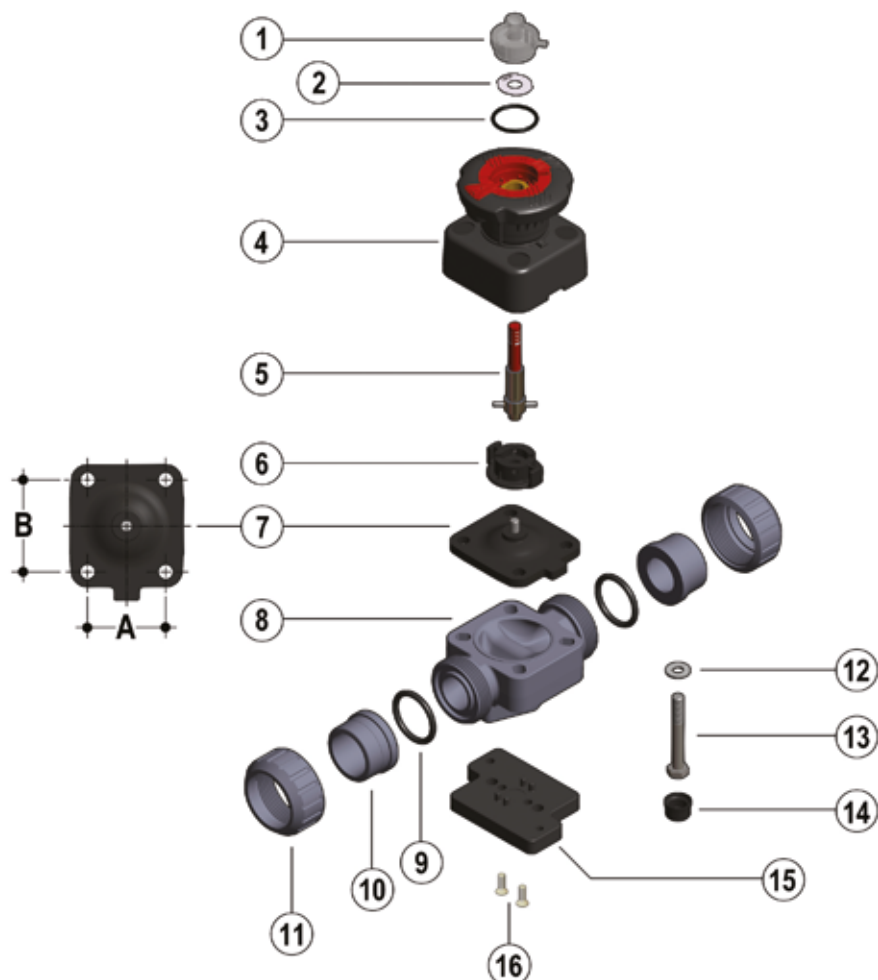

DN	15	20	25	32	40	50	65
A	40	40	46	46	65	78	78
B	44	44	54	54	70	82	82

- |  |  |   |
|--|--|---|
| <b>1</b> Transparent protection cap (PVC - 1)*           | <b>6</b> Compressor (PA-GR IXEF® - 1)          | <b>11</b> Union nut (PVC-U - 2)*        |
| <b>2</b> Customisation plate (PVC-U - 1)                 | <b>7</b> Diaphragm seal (EPDM, FKM, PTFE - 1)* | <b>12</b> Washer (STAINLESS steel - 4)  |
| <b>3</b> O-Ring (EPDM - 1)                               | <b>8</b> Valve body (PVC-U - 1)*               | <b>13</b> Bolt (STAINLESS steel - 4)    |
| <b>4</b> Operating mechanism (PP-GR / PVDF - 1)          | <b>9</b> Socket seal O-Ring (EPDM-FKM - 2)*    | <b>14</b> Protection plug (PE - 4)      |
| <b>5</b> Threaded stem – Indicator (STAINLESS steel - 1) | <b>10</b> End connector (PVC-U - 2)*           | <b>15</b> Distance plate (PP-GR - 1)**  |
|  |  | <b>16</b> Screw (STAINLESS steel - 2)** |

\* Spare parts

\*\* Accessories

The material of the component and the quantity supplied are indicated in brackets

## DISASSEMBLY

- 1) Isolate the valve from the line (release the pressure and empty the pipeline).
- 2) Unlock the handwheel if necessary by pushing it downwards (fig.5), and open the valve completely by turning it counter-clockwise.
- 3) Unscrew the union nuts (11) and extract the valve.
- 4) Remove the protection plugs (14) and remove the bolts (13) with the relative washers (12).
- 5) Separate the valve body (8) from the operating mechanism (4).
- 6) Rotate the handwheel clockwise until the threaded stem (5), the compressor (6) and the diaphragm (7) are released.
- 7) Unscrew the diaphragm (7) and remove the shutter (6).

## ASSEMBLY

- 1) Insert the compressor (6) onto the threaded stem (5), aligning it correctly with the stem pin.
- 2) Screw the diaphragm (7) onto the threaded stem (5).
- 3) Lubricate the threaded stem (5) and insert it into the operating mechanism (4), then turn the handwheel counter-clockwise until the stem is fully screwed in (5). Make sure that the compressor (6) and the diaphragm are properly aligned with the respective slots in the operating mechanism (4) (fig. 7).
- 4) Assemble the operating mechanism (4) on the body of the valve (8) and tighten the bolts (13) with the relative washers (12).
- 5) Tighten the bolts (13) evenly (diagonally) to the tightening torque suggested on the relative instruction sheet.
- 6) Replace the protection plugs (14).
- 7) Position the valve body between the end connectors (10) and tighten the union nuts (11), making sure that the socket seal O-rings (9) do not exit their seats.
- 9) If necessary, lock the handwheel by gripping it and pulling it upwards (fig.6).



**Note:** during assembly operations, it is advisable to lubricate the threaded stem Mineral oils are not recommended for this task as they react aggressively with EPDM rubber.

Fig. 5



Fig. 6



Fig. 7



# INSTALLATION

Before proceeding with installation, please follow these instructions carefully: (instructions refer to versions with union ends). The valve can be installed in any position and in any direction.

- 1) Check that the pipes to be connected to the valve are aligned in order to avoid mechanical stress on the threaded joints.
- 2) Unscrew the union nuts (11) and insert them on the pipe segments.
- 3) Solvent weld or screw the end connectors (10) onto the pipe ends.
- 4) Position the valve body between the end connectors making sure the socket seal O-Rings (9) do not exit the seats.
- 5) Fully tighten the union nuts (11).
- 6) If necessary, support the pipework with FIP pipe clips or by means of the carrier built into the valve itself (see paragraph "Fastening and supporting").

**Note:** Before putting the valve into service, check that the bolts on the valve body (13) are tightened correctly at the suggested torque.

Fig. 9



## LOCKING DEVICE

The DK valve is equipped with a DIALOCK® handwheel locking system that prevents the valve from being operated.

The system can be used simply by lifting the handwheel once it reaches the desired position (fig. 8).

To unlock, simply move the handwheel back to the previous position by pressing downwards (fig. 6).

When the system is in a locked position, it is also possible to install a lock to protect the system against tampering (fig. 9).

The diameter of the hole to put the padlock in is 4,5 mm for the dimensions between DN 15 and DN 32 and 6,5 mm for the dimensions between DN 40 and DN 65.



## STROKE LIMITER

The DKL version of the diaphragm valve is equipped with a handwheel stroke control system which allows the minimum and maximum flows to be preset and preserves the diaphragm from excessive compression during closing operations. The system allows the valve stroke to be modified using the two independent adjusting screws, which determine the mechanical limits of the valve during opening and closing. The valve is sold with the stroke limiters positioned so as not to limit the stroke both

during closing and opening.

To access and set the adjusting screws, remove the transparent protection cap (A) as previously described (see chapter "Customisation").

### Travel stop adjustment. Minimum flow rate or valve closed.

- 1) Turn the handwheel clockwise until the desired minimum flow rate or the closed position is reached.
- 2) Fully screw the nut (D) to limit stop, and lock it in this position by tightening the locknut (E). If you want to exclude the stroke limiting function during closing, unscrew the nuts (D and E) completely. In this way, the valve will close completely.
- 3) Re-assemble the transparent protection cap making sure that the seal O-Ring remains in its seating.

### Stroke limiter adjustment. Maximum flow rate

- 1) Turn the handwheel counter-clockwise until the desired maximum flow rate is reached.
- 2) Turn the knob (F) counter-clockwise to limit stop. The plate shows the direction of rotation of the wheel to obtain a smaller or greater maximum flow rate. If it is not necessary to limit the opening stroke, turn the knob (F) clockwise several times. In this way, the valve will open completely.
- 3) Re-assemble the transparent protection cap making sure that the seal O-Ring remains in its seating.

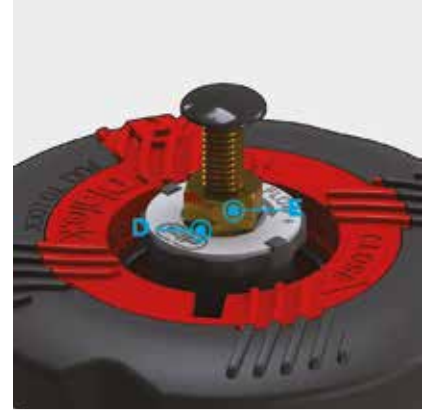



# VM DN 80÷100

The VM is particularly suitable for shutting off and regulating abrasive or dirty fluids. The handwheel control and diaphragm seal provide precise and effective control, while reducing the risk of water hammer to a minimum.

## DIAPHRAGM VALVE

- **Optimised fluid dynamic design:** maximum output flow rate thanks to the optimised efficiency of the fluid dynamics that characterise the new internal geometry of the body
- Handwheel that stays at the same height during rotation, with internal bearing to minimise friction and operating torque
- Standard optical indicator
- **Internal operating components in metal** totally isolated from the conveyed fluid
- Bonnet fastening screws in STAINLESS steel protected against the external environment by PE plugs
- **New flanged bodies:** the new bodies, characterised by a monolithic flanged structure, are available in PVC-U, PVC-C, PP-H and PVDF. This design, free from body and flange joints, greatly reduces mechanical stress and increases system performance.

Technical specifications	
Construction	Single wear diaphragm valve
Size range	DN 80 ÷ 100
Nominal pressure	PN 10 with water at 20° C
Temperature range	0 °C ÷ 60 °C
Coupling standards	<b>Flanging system:</b> ISO 7005-1, EN ISO 1452, EN ISO 15493, EN 558-1, EN 1092-1, ANSI B.16.5 cl. 150.
Reference standards	<b>Construction criteria:</b> EN ISO 16138, EN ISO 1452, EN ISO 15493 <b>Test methods and requirements:</b> ISO 9393 <b>Installation criteria:</b> DVS 2204, DVS 2221, UNI 11242
Valve material	<b>Body:</b> PVC-U <b>Bonnet:</b> PP-GR <b>Handwheel</b> PA-GR
Seal material	EPDM (on request NBR)
Control options	Manual control; pneumatic actuator

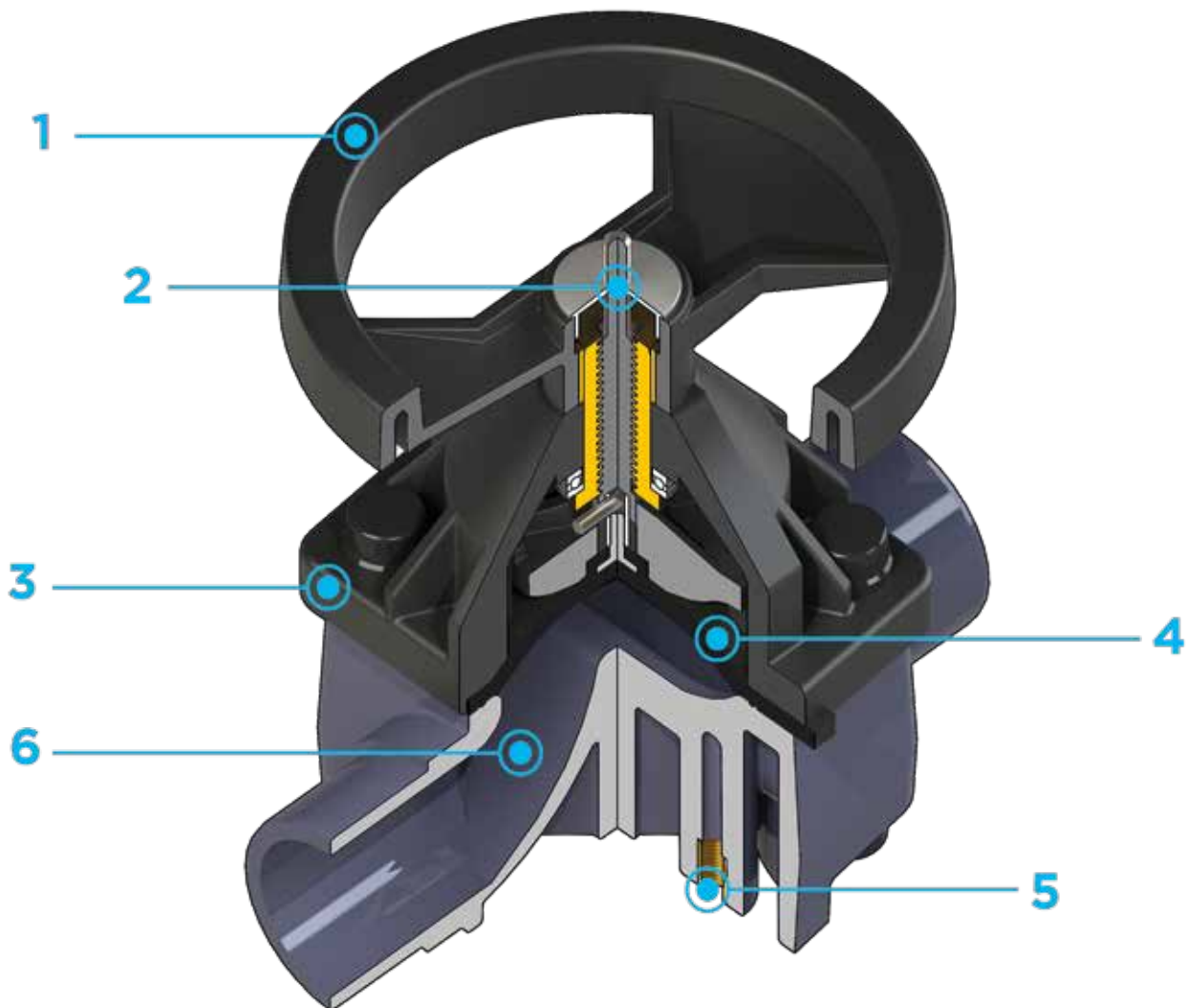

- 1** Handwheel in (PA-GR) with high mechanical strength and ergonomic **grip for optimum manageability**
- 2** **Metal optical position indicator** supplied as standard

- 3** **Full protection bonnet in PP-GR** Internal circular and symmetrical diaphragm sealing area
- 4** Diaphragm available in EPDM, FPM, PTFE (NBR on request) and easy to replace

- 5** **Threaded metal inserts** for anchoring the valve
- 6** **New valve body internal design:** substantially higher flow coefficient resulting in lower pressure drops. Optimised adjustment curve for effective and precise flow rate regulation

# TECHNICAL DATA

## PRESSURE VARIATION ACCORDING TO TEMPERATURE

For water and non-hazardous fluids with regard to which the material is classified as CHEMICALLY RESISTANT. In other cases, a reduction of the nominal pressure PN is required (25 years with safety factor).

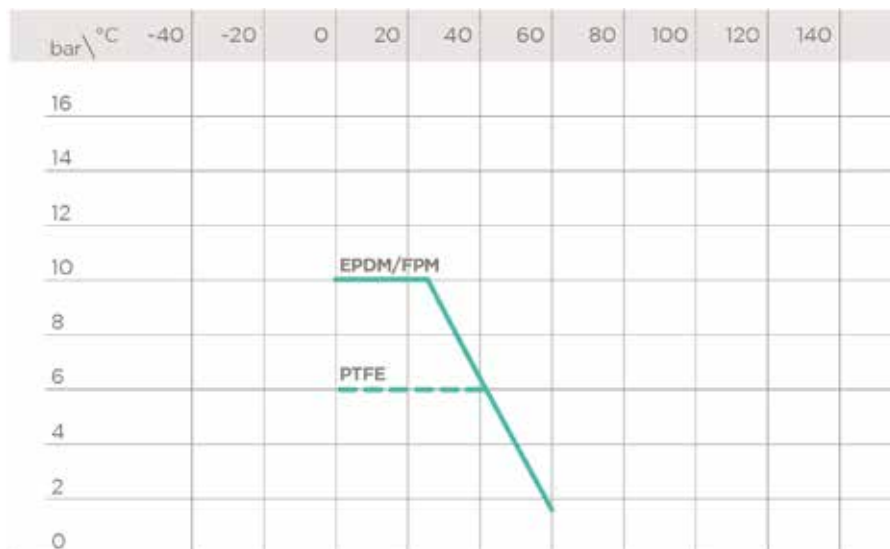

## PRESSURE DROP GRAPH

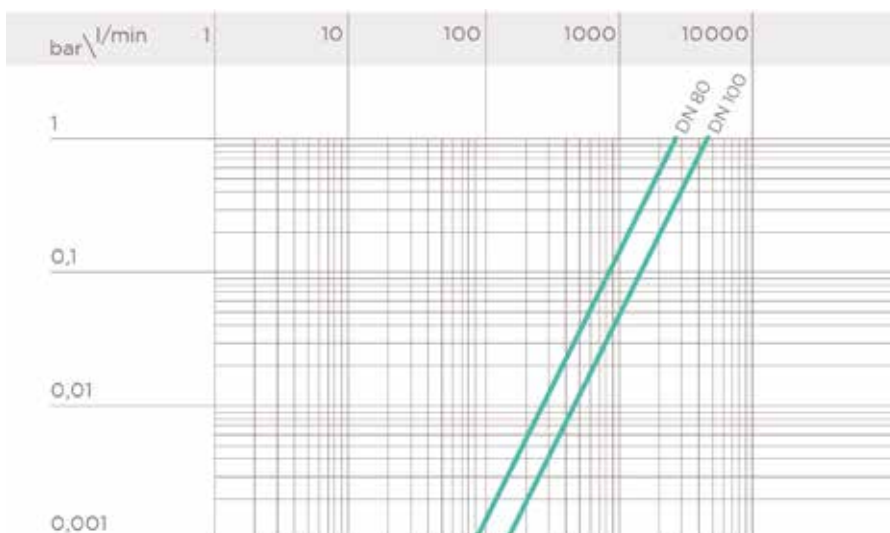

## K<sub>v</sub>100 FLOW COEFFICIENT

The K<sub>v</sub>100 flow coefficient is the Q flow rate of litres per minute of water at a temperature of 20°C that will generate Δp= 1 bar pressure drop at a certain valve position. The Kv100 values shown in the table are calculated with the valve completely open.

DN	80	100
Kv100 l/min	2910	4620

The information in this leaflet is provided in good faith. No liability will be accepted concerning technical data that is not directly covered by recognised international standards. FIP reserves the right to carry out any modification. Products must be installed and maintained by qualified personnel.



# DIMENSIONS

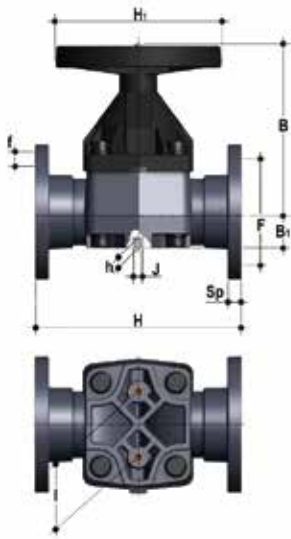

## VMOV

Diaphragm valve with flanged monolithic body, drilled PN10/16. Face to face according to EN 558-1

d	DN	PN	B	B <sub>1</sub>	F	f	H	H <sub>1</sub>	I	J	Sp	U	g	EPDM code
90	80	*10	225	64	160	18	310	200	100	M12	21,5	8	8500	VMOV090E
110	100	*10	295	72	180	18	350	250	120	M12	22,5	8	12400	VMOV110E

\*PTFE PN6

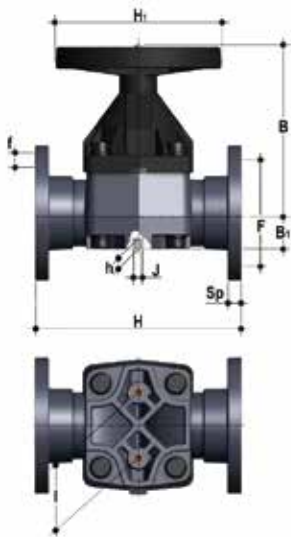

## VMOAV

Diaphragm valve with flanged monolithic body, drilled ANSI B16.5 cl. 150 #FF

d	DN	PN	B	B <sub>1</sub>	F	f	H	H <sub>1</sub>	I	J	Sp	U	g	EPDM code
3"	80	*10	225	64	152,4	19,1	263	200	100	M12	21,5	4	8500	VMOAV300E
4"	100	*10	295	72	190,5	19,1	328	250	120	M12	22,5	8	12400	VMOAV400E

\* PTFE: PN 6

For installation prior to october 2017 please contact Fip Technical Support

# COMPONENTS

## EXPLODED VIEW

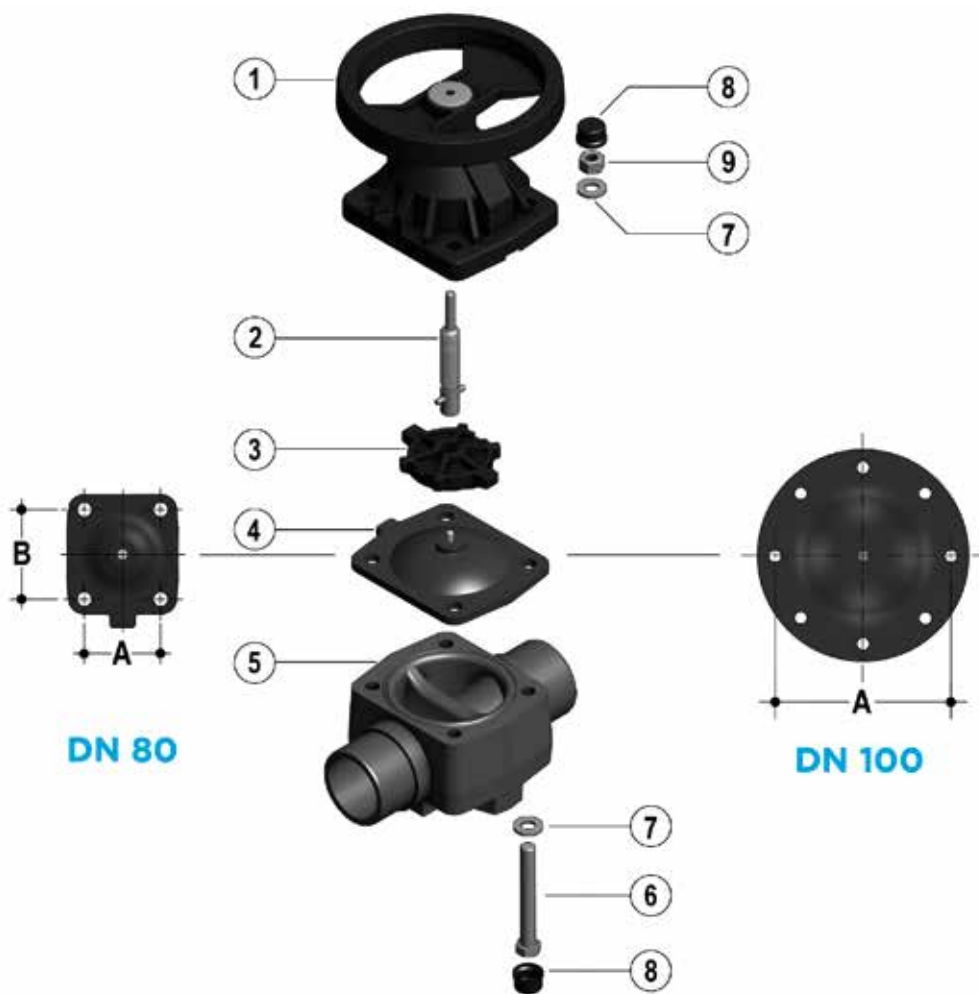

DN	80	100
A	114	193
B	127	-

- |  |  |   |
|--|--|---|
| <b>1</b> Bonnet (PP-GR - 1); Handwheel (PA-GR - 1) | <b>4</b> Diaphragm seal (EPDM, FKM, PTFE - 1)    | <b>7</b> Washer (Zinc plated steel - 4) |
| <b>2</b> Indicator - stem (STAINLESS steel - 1)    | <b>5</b> Body (PVC-U - 1)                        | <b>8</b> Protection plug (PE - 4)       |
| <b>3</b> Shutter (PBT - 1)                         | <b>6</b> Hexagonal screw (Zinc plated steel - 4) | <b>9</b> Nut (Zinc plated steel - 4)    |

The material of the component and the quantity supplied are indicated in brackets

## DISASSEMBLY

The diaphragm constitutes the part of the valve more subject to mechanical and chemical stress from the fluid. Consequently, the condition of the diaphragm must be checked at regular intervals in accordance with the service conditions. To do this, it must be disconnected from the handwheel and from the valve body.

- 1) Cut-off fluid upstream from the valve and make sure it is de-pressurised (downstream drain if necessary).
- 2) Unscrew the four screws (6) and separate the body (5) from the internal components.
- 3) Unscrew the diaphragm (4) from the shutter (3). Rotate the handwheel clockwise to free the stem-shutter unit. Clean or replace the diaphragm, if necessary (4). If necessary, lubricate the stem (2).

## ASSEMBLY

- 1) Apply the shutter (3) to the stem (2), ensuring the stem pin is positioned correctly.
- 2) Screw the diaphragm (4) onto the stem (2), taking care not to stretch it.
- 3) Open the valve.
- 4) Place the bonnet-handwheel unit (1) on the body (5) and join the two components with bolts.
- 5) Press the protection plugs into place (8).

# INSTALLATION

The valve can be installed in any position and in any direction.

When starting up the plant, make sure that there are no leaks from between the diaphragm and the valve body. If necessary, tighten the fastening screws (6).

## WARNINGS

**Note:** during assembly operations, it is advisable to lubricate the threaded stem. Mineral oils are not recommended for this task as they react aggressively with EPDM rubber.

Moreover, as the diaphragm seal is compressed between the body and the actuator, the valve body stud-bolts and nuts must be checked and tightened, if necessary, prior to installation.



# CR DN 40÷300

The CR wafer check valve is designed to be installed directly between stubs and flanges in accordance with ISO/DIN standards.

## WAFER CHECK VALVE

- Installed with FIP QPV (d50 - d160) stubs and QRV stubs using flat gasket QHV/Y (d225 - d315), on PVC piping class PN10 or lower with type ODV flanges
- **Metal support for easy and precise centring** of the valve during installation
- Can be installed in either a vertical or horizontal position
- **Sealing system with O-ring** for optimum sealing and installation without flat gaskets

Technical specifications	
Construction	Wafer check valve
Size range	DN 40 ÷ 300
Nominal pressure	5 bar with water at 20 °C
Temperature range	0 °C ÷ 60 °C
Coupling standards	<b>Flanging system:</b> EN 1092-1 PN 10, EN ISO 1452, EN ISO 15493
Reference standards	<b>Construction criteria:</b> EN ISO 16137 EN ISO 1452, EN ISO 15493
	<b>Test methods and requirements:</b> ISO 9393
	<b>Installation criteria:</b> DVS 2204, DVS 2221, UNI 11242
Valve material	PVC-U
Seal material	EPDM

# TECHNICAL DATA

## PRESSURE VARIATION ACCORDING TO TEMPERATURE

For water e non-hazardous fluids with regard to which the material is classified as CHEMICALLY RESISTANT. In other cases, a reduction of the nominal pressure PN is required (25 years with safety factor).



## PRESSURE DROP GRAPH

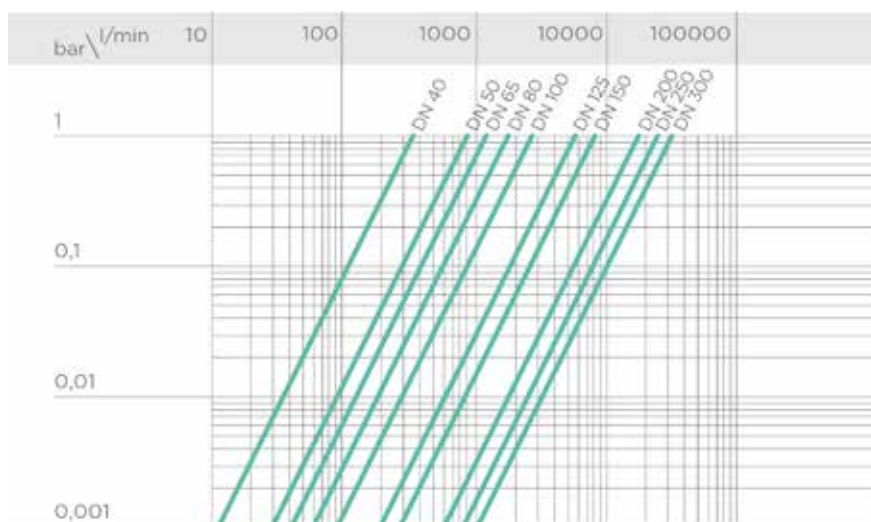

## K<sub>v</sub>100 FLOW COEFFICIENT

The K<sub>v</sub>100 flow coefficient is the Q flow rate of litres per minute of water at a temperature of 20°C that will generate Δp= 1 bar pressure drop at a certain valve position. The Kv100 values shown in the table are calculated with the valve completely open.

DN	40	50	65	80	100	125	150	200	250	300
Kv100 l/min	370	900	1250	1867	2867	5700	8167	18800	25000	31900

## MINIMUM PRESSURE REQUIRED TO OPEN THE VALVE IN A VERTICAL FLOW

DN	40	50	65	80	100	125	150	200	250	300
bar	0,002	0,003	0,003	0,003	0,003	0,003	0,005	0,005	0,008	0,008

## MINIMUM VALVE SEALING PRESSURES

DN	40	50	65	80	100	125	150	200	250	300
bar	0,3	0,3	0,3	0,2	0,2	0,2	0,2	0,2	0,2	0,2

## TIGHTENING TORQUE

DN	40	50	65	80	100	125	150	200	250	300
Nm*	8	10	10	10	0	15	20	38	45	50

\*Tightening torques for nuts and bolts on couplings with backing rings. Values required to obtain the hydraulic test seal (1.5 x PN at 20°C) (new or lubricated nuts and bolts)



# DIMENSIONS

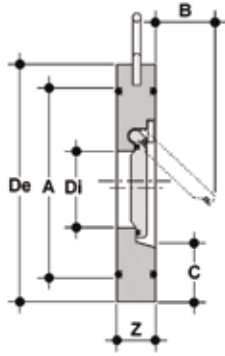

## CROV

Wafer check valve in PVC-U/EPDM

d	DN	A	B	C	ISO/DIN	Di	OP	Z	g	*MOP (bar)	Code
50	40	72	25	28	95	22	0-5	16	160	6	CROV050E
63	50	86	37	29	109	32	0-5	20	260	6	CROV063E
75	65	105	50	31	129	40	0-5	20	330	6	CROV075E
90	80	119	61	32	144	54	0-5	20	400	6	CROV090E
110	100	146	77	31	164	70	0-5	22	560	6	CROV110E
140	125	173	94	35	195	92	0-5	23	760	6	CROV140E
160	150	197	100	40	220	105	0-5	25	1120	6	CROV160E
225	200	255	152	38	275	154	0-5	35	2130	6	CROV225E
280	250	312	180	41	330	192	0-5	40	3540	6	CROV280E
315	300	363	215	41	380	227	0-5	45	5350	6	CROV315E

# INSTALLATION

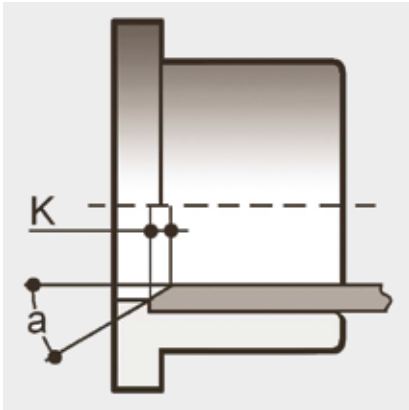

- During installation, make sure that the following requirements are complied with:
- 1) Leave a straight section of pipe of length equal to 5 times the nominal diameter before and after the valve.
  - 2) Do not install the valve directly on the pump flange. The use of flat gaskets is recommended in order to guarantee a perfect seal between the valve and stubs with serrated face.
  - 3) Do not use pipes of thickness more than that of PN10 pipes.
  - 4) The CR valve can be used on vertical pipes only if the fluid flow is upwards.
  - 5) After having aligned the valve with the stub, tighten the flange bolts in a diagonal sequence to the required torque.
- For sizes d110 and d160, in order to prevent impact between the disk and pipe, insert a spacer or chamfer the pipe itself as shown in fig.1 and indicated in the table.

d	Angle a for PN10 pipes	K (mm) for PN10 pipes
110	15°	5
160	30°	9

# KEY

## Abbreviations

<b>ABS</b>	Acrylonitrile butadiene styrene
<b>d</b>	Nominal external diameter of the pipe in mm
<b>DN</b>	Nominal internal diameter of the pipe in mm
<b>EPDM</b>	Ethylene-Propylene-Diene-Monomer
<b>FKM (FPM)</b>	Fluoroelastomer
<b>g</b>	Weight in grams
<b>HIPVC</b>	PVC high impact
<b>K</b>	Lid key
<b>NBR</b>	Nitrile butadiene rubber
<b>OP</b>	Working pressure
<b>P</b>	Hose adaptor
<b>PA</b>	Polyamide
<b>PA-GR</b>	Fibreglass reinforced polyamide
<b>PBT</b>	Polybutylene terephthalate
<b>PE</b>	Polyethylene
<b>PN</b>	Nominal pressure in bar (max.operating pressure at 20°C water)
<b>POM</b>	Polyoxymethylene
<b>PP-GR</b>	Fibreglass reinforced polypropylene
<b>PP-H</b>	Polypropylene homopolymer
<b>PVC-C</b>	Chlorinated polyvinyl chloride
<b>PVC-U</b>	Unplasticized polyvinylchloride
<b>PVDF</b>	Polyvinylidene difluoride
<b>PTFE</b>	Polyethrafluorethylene
<b>R</b>	Nominal thread size in inches
<b>s</b>	Pipe thickness in mm
<b>SDR</b>	Standard dimension ratio = d/s
<b>U</b>	Number of flange holes for flanged valves



**Aliaxis Italia - FIP S.p.A**

Loc. Pian di Parata, 16015 Casella Genova Italy

Tel. +39 0109621.1 - Fax +39 010 9621.209

info.fip@alixis.com

**www.alixis.it**

UNI EN  
ISO 9001  
QUALITÀ

UNI EN  
ISO 14001  
GESTIONE  
AMBIENTALE

